

# ProPEX lead-free (LF) brass flange adapter kits

## Project Information

Job name:	Location:
Engineer:	Date submitted:
Contractor:	Submitted by:
Manufacturer's representative:	Approved by:

## Technical data

Material	LF Brass
Temp/pressure ratings	73 °F (23 °C) at 160 psi (11 bar) 180 °F (82 °C) at 100 psi (6.9 bar) 200 °F (93 °C) at 80 psi (5.5 bar)
Prop 65 label required?	Yes

## Product information and application use

ProPEX® Lead-free (LF) Brass Flange Adapter Kit connects Uponor PEX tubing to any compatible flange. Flanges conform to ANSI 16.5 150 Standard, are powder coated with an EPDM insulator adhered to the plate steel flange protruding inside of the steel flange to prevent contact with the LF brass flange adapter.

Note: Temperature and pressure ratings stated are hydrostatic ratings. For domestic hot-water (DHW) and DHW recirculation installations, operating conditions should not exceed 140°F (60°C) at 80 psi (5.5 bar) in accordance with ASTM F2023. For additional information regarding application-specific temperature and pressure ratings, refer to the Uponor PEX Piping Systems Design and Installation Manual.

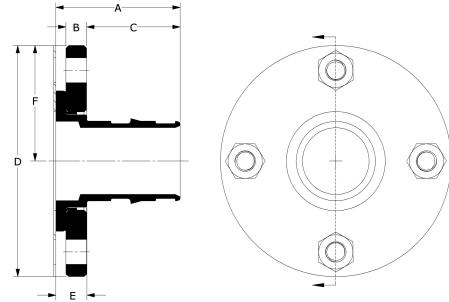

Part name	Part no.	A [mm]	B [mm]	C [mm]	D [mm]	E [mm]	F [mm]	Cv	End Type 1	End Type 2	Weight per UOM [kg/UOM]
ProPEX LF Brass Flange Adapter Kit, 2 1/2" PEX (Class 150)	LF2982525	95.76	16	67.64	177.80	163.40	88.90	131.5	ProPEX 2-1/2"	Flange 2-1/2"	4.173
ProPEX LF Brass Flange Adapter Kit, 3" PEX (Class 150)	LF2983030	109.73	16	86.03	190.50	23.70	95.25	311	ProPEX 3"	Flange 3"	4.899

Part name	Part no.	Codes	Standards	Listings
ProPEX lead-free (LF) brass flange adapter kits	All	UPC IMC IPC IBC IRC UMC NSPC NPC of Canada	ASTM F1960 CSA B137.5 NSF/ANSI 14 NSF/ANSI/CAN 61 NSF/ANSI/CAN 372 ASTM F877	IAPMO-ESI ICC-ES-PMG U.P.Code HUD MR 1269 cNSFus-pw-G

## Installation

ProPEX Expansion Tool and ProPEX Rings (sold separately) are required for connecting the PEX tubing. Refer to the Uponor AquaPEX® Professional Plumbing Installation Guide or Uponor Hydronic Piping Design Assistance Manual for additional information.

## Related applications

- PEX-a Plumbing Systems
- Hydronic Radiant Heating and Cooling Systems
- Snow Melting Systems
- Turf Conditioning Systems
- Permafrost Prevention Systems

## Footnotes

-

## Contact information

Uponor Inc.  
5925 148th Street West  
Apple Valley, MN 55124  
T 800.321.4739  
F 952.891.2008

Uponor Ltd.  
6510 Kennedy Road  
Mississauga, ON L5T 2X4  
T 888.594.7726  
F 800.638.9517