

# The Basics of Weholite Pipe System

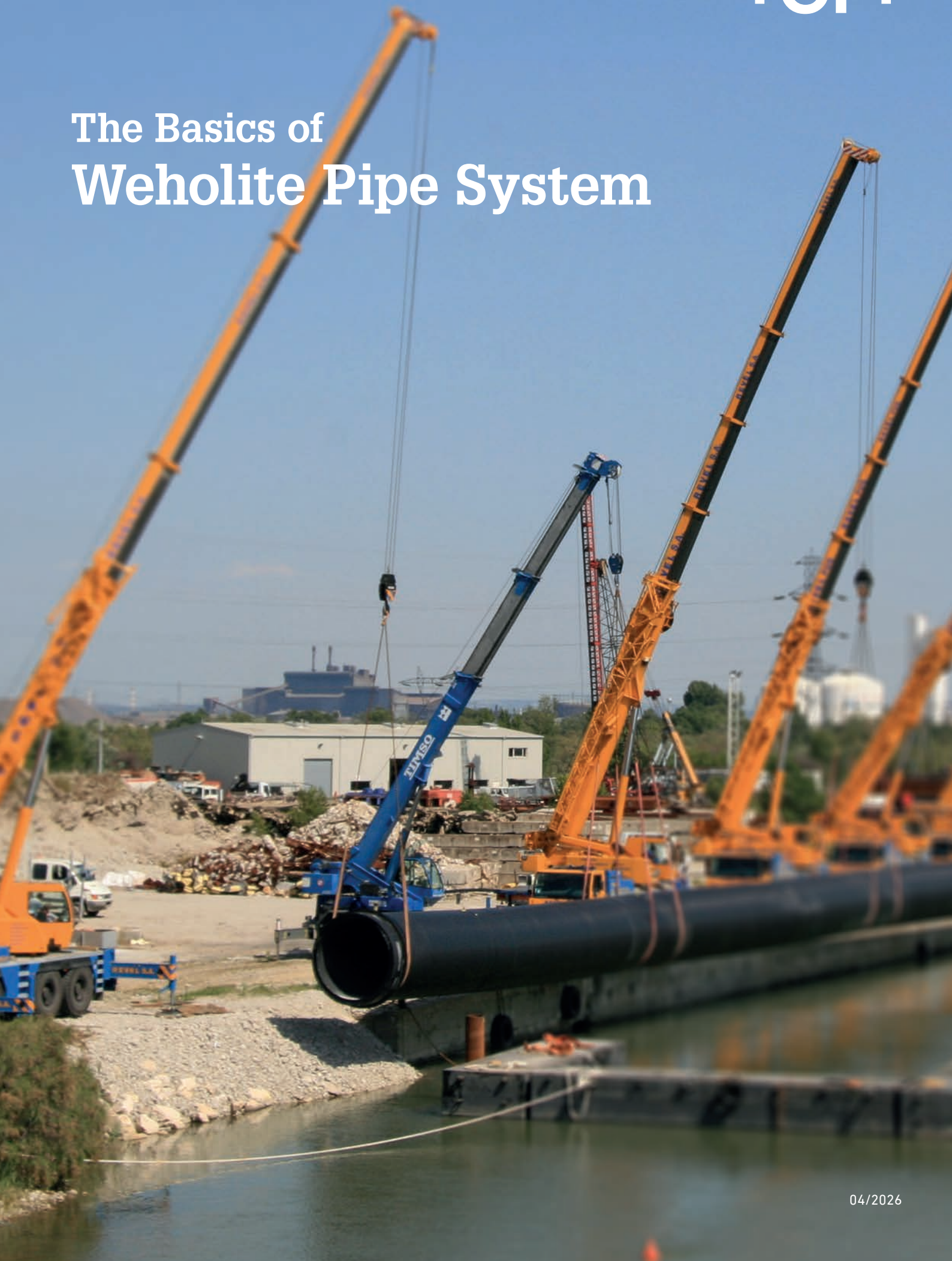

# Contents

<b>Introduction</b>	<b>3</b>
Sewers	4
Culverts	6
Renovation	7
Stormwater systems	8
Open ditches	9
Industrial pipework	10
Ventilation pipes	11
Marine installations, Project Services	12
Low-pressure pipelines	14
Special constructions	15
Tanks	16
<b>Products, dimensions</b>	<b>18</b>
Pipes	18
Bends	19
Equal tees	20
Double sockets	21
Flange joints	21
Wall anchoring	22
Manholes	22
<b>Design, installation</b>	<b>23</b>
Material properties	23
Hydraulic design	23
Structural design	25
Buckling resistance	26
Design graph for pipe selection	27
Trench works	28
Bending	29
Support spacing	29
Buoyancy	29
<b>Jointing</b>	<b>30</b>
Rubber sealings	30
Heat shrink sleeves	30
Socket joint	30
Extrusion welding	31
Sleeve joints	31
Thread joint	31
Jointing methods	32
<b>Handling, transportation and storage</b>	<b>33</b>
<b>Quality control</b>	<b>34</b>
<b>Site testing</b>	<b>35</b>



Bury St. Edmunds, Great Britain:  
A stormwater retention tank made of Weholite pipe. Total length 1200m, DN/ID 2800mm, total volume more than 7000m<sup>3</sup>.

# Introduction

Our experience with handling and production of plastic products has shown us that plastic pipes made of Polyethylene are the best suitable for most pipe applications, non-pressure as well as pressure.

Structured-wall pipes had their breakthrough in the 1990's and the development continues. Modern production technology paired with high-quality raw-materials enables new types of pipe structures.

Uponor Infra has focused on structured-wall pipe development. We would like to present Weholite, a result of technical know-how and development. The patented structure of Weholite enables plastic pipe production and use up to an internal diameter of 3500mm.

Weholite is a flexible, light and durable investment: The pipe does not rot, rust or corrode due to any chemical or electrical reaction in the soil. The foreseeable lifetime for soil-installed plastic pipes is over 100 years.

Thanks to the unique production method, we can design and manufacture both the pipe diameter and stiffness according to the customer's needs.

The excellent abrasion resistance and flexibility of the PE-material make Weholite a truly multifunctional pipe; quick and easy to install thanks to its light construction.



## Sewers



Stormwater-, and sewerage pipe systems as well as groundwater protection were installed in connection with the renewal of highway 6 between Lappeenranta and Imatra, Finland. In this large project, several hundred manholes and several kilometres of Weholite pipes DN/ID 500-900mm were installed.



Arabianranta, Helsinki, Finland: Weholite stormwater pipe DN/ID 1000mm. The 12 metre long Weholite pipes with thread joints were quick to install and easy to handle.



Kotka, Finland: Weholite DN/ID 1000mm transmission lines for Kymen Vesi Oy's treatment plant. Installation was sped up with 15 metre installation lengths. The extrusion welding jointing method is watertight and withstands tensile forces.



Raisio, Finland: 350 metres DN/ID 2000mm and 40 metres DN/ID 800mm Weholite pipe with thread joints were installed as drainage pipes for an industrial site. The joints were sealed with shrink-sleeves and saddle manhole connections were extrusion welded from the inside.



Ilmajoki, Finland: The total length for the waste deposit collector pipeline is more than 2550m and it consists of Weholite pipes DN/ID 600 and 700mm, stiffness class SN4.



Gdynia, Poland: Wastewater treatment plant discharge pipes. Uponor delivered 2257m Weholite pipes DN/ID 1400–1500mm and 22 manholes. To facilitate installation, most pipes were delivered in 15m lengths.

## Culverts

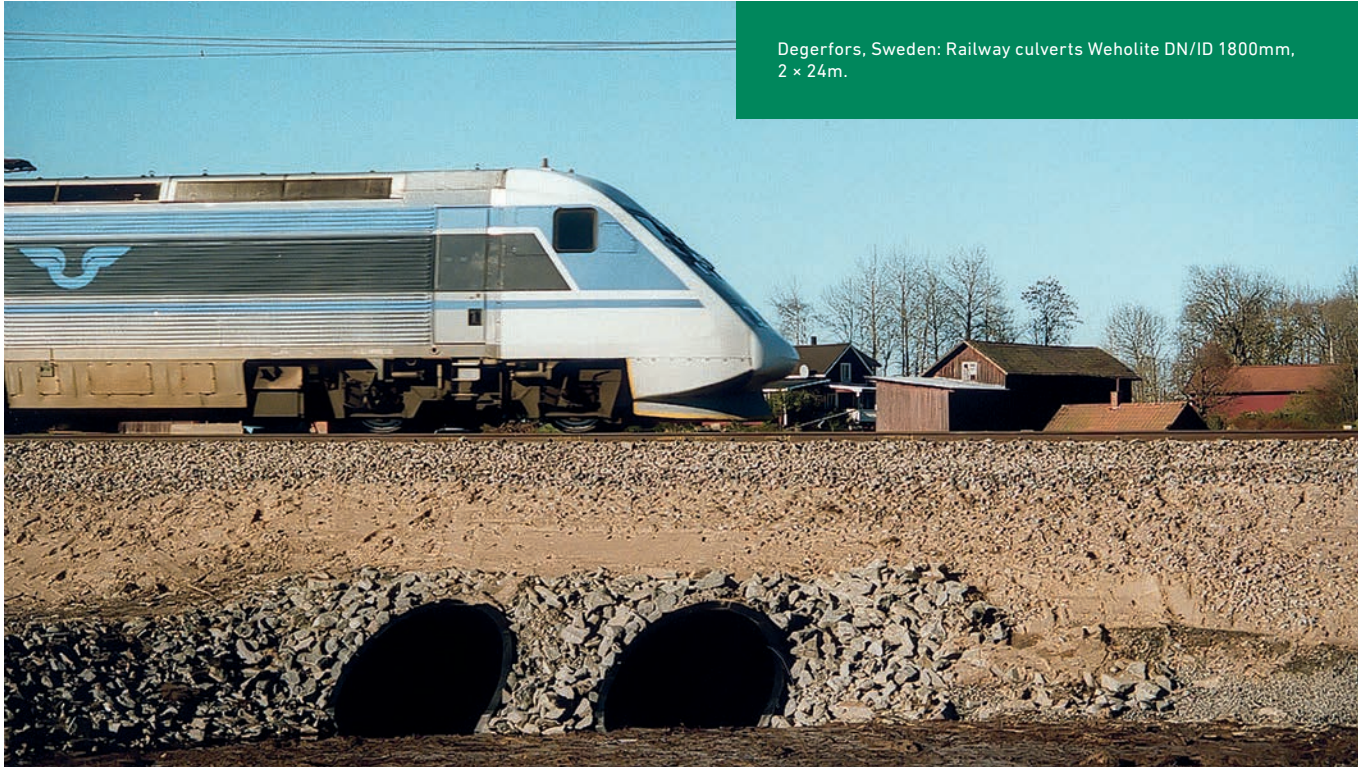

Highway 4 Lahti – Heinola, Finland: This extensive project aimed to remove traffic jams between Lahti and Heinola, and to improve traffic safety. Weholite pipes DN/ID 400 – 1800mm with thread joints were delivered to the project. The pipes were installed in open trenches and as relining pipes. The installation progressed quickly in teams of one-two men and one excavator. A third-party report on long-term deformation was prepared by VTT for Weholite culvert pipes DN/ID 1600mm SN4. This report is available as VTT-S-11213-07, 19.12.2007.



Highway 6 Koskenkylä – Kouvola, Finland: an “old and dangerous” road became a modern wide-lane road. Security and traffic flow improved. All needed culvert piping for the main road and side roads were Weholite pipe in sizes DN/ID 360 – 2000mm SN4.

## Renovation



Vaasa, Finland: Weholite pipe DN/ID 700mm was used to renovate a culvert pipe.



Åvabro, Åland Islands: An old corrugated steel road culvert was renovated by sliplining a Weholite pipe DN/ID 1600mm SN4, total length 30m.



Hämeenlinna, Finland: A highway crossing was renovated by sliplining a Weholite pipe DN/ID 1000/1125mm into a concrete pipe DN 1300mm. Jointing type: Extrusion welding. Total length 750m.

## Stormwater systems



Porvoo, Finland: A Stormwater system was installed in an industrial area with in very tight surroundings. A bespoke Weholite tank DN/ID 1200mm, 80m long, now functions as buffer tank for the stormwater flow. The tank was delivered as 20m long pipes that were welded together on site.



Bury St. Edmunds, Great Britain: A stormwater retention tank made of Weholite pipe. Total length 1200m, DN/ID 2800mm, total volume more than 7000m<sup>3</sup>.



Växjö, Sweden: A bespoke retention tank 1000m<sup>3</sup> buffers the flows in the neighboring area stormwater network. Växjö decided on a Weholite tank because of its quick installation, long life and flexible construction, as well as the absolute tightness.



San Clemente, CA. USA: 2042m Weholite pipe DN/ID 2134–3048mm and in total 75 bends were installed as storm water pipework for a residential area.

## Open ditches

Jepua, Finland: Piping of an open ditch. A total length of 52m Weholite DN/ID 1800mm was installed for this project, where the Ostrobothnia track was renovated to prevent frost damage from frozen soil.



Vantaa, Finland: On a 9 hectare area planned as storage space for cars, open ditches were piped with Weholite pipes to get the full area utilized. For the project, 258m DN/ID 1200mm Weholite pipe, 198m DN/ID 1400mm pipe and 11 saddle manholes were installed. The joints were made with thread joints and sleeves.



Espoo, Finland: Transfer and piping of the Monikonpuro ditch. White Weholite DN/ID 2200mm, 150m.

## Industrial pipework



Uponor Infra delivered more than 10 kilometres of different kinds of pipes to a dry land fish farming facility in Eckerö, in the Åland Islands – an archipelago in the Baltic Sea. The original plan was to install pressure pipes but Uponor's experts ensured the customer to replace them at a lower cost with Weholite pipes DN/ID 1800mm. This was a good example of why it is important to contact experts at an early stage of a project.



Kemijärvi, Finland: The discharge pipeline for the wastewater treatment sludge from this Pulp mill was built from a Weholite pipe DN/ID 700mm with a total length of 1050m. The pipeline is connected to the pumping station with a flange connection, and the treated water is discharged into Kemijärvi lake. For technical reasons, the pipeline was installed above-ground. Soil anchors to prevent temperature-induced movement were built from 6m<sup>3</sup> concrete blocks.



Beckton, London: Outfall for treated sewage. The project included two 440m Weholite DN/ID 3000mm pipes, engineering, material delivery, welding service, profile filling, PE boxes and installation supervision. Due to the required amount of backfill, the LP SN6 was chosen to the land section while the marine installation was carried out with the SN4.



Weholite used as protection pipes due to the heavy traffic load at the SCA pulp factory in Sweden. Inside the Weholite pipes are the main process water DN 900mm solid wall pipes installed.

## Ventilation pipes



Denmark: Biogas reactor scrubbers clean the air from noxious gases and fumes. Weholite is also suitable for pipework in biogas power plants.



Sønderborg, Denmark: Collector pipes for geothermal air heating under a school building. Installation length 16m, installation depth 2m.

## Marine installations, Project Services



Jyväskylä, Finland: The cooling water pipeline for a biopower plant, Weholite DN/ID 3000mm. Pipes supplied to site in 20m lengths, installation lengths 300m. The total length of the intake and outfall pipes is 1714m.

Marine installations of intake and outfall pipes are multistage projects comprising pressure-, and strength calculations, material deliveries, welding works and assembly as well as the installation itself. Uponor delivers all services ready to use and is one of the leading companies in the field on the strength of our long experience.

### The services provided include:

- Detailed engineering including part drawings of all delivered material, strength calculations and description of all work included in the scope, installation instructions and simulations, stability calculations of pipelines, lifting operations, users manuals etc.
- Material deliveries
- Field welding service and ballasting of pipe
- Subcontractors
- Supervision
- Operation

Weholite is suitable for marine installations: It is impervious to salt water and corrosion, the welding joints are watertight and the dimensions extend up to DN/ID 3500mm. The handling and installation of the light pipe is easy also for large dimensions. The flexible Weholite adapts to loading differences on the sea floor better than a pipe made of a stiff material.

Traditional plastic pipes with a solid wall construction are normally ballasted against buoyancy with external concrete weights. This is also possible with Weholite, but it is recommended to utilize the pipe wall construction: The profile space can be filled with concrete mortar. This method saves dredging costs, as the pipe wall ballasting procedure enables a narrower trench than external ballasting alternatives.

Internal profile ballasting is also quick to install, demands less heavy equipment and the welding jobsite does not need to be

in the same place as the installation site. The pipeline parts can be towed to their final installation site using pontoons and tugboats. Uponor representatives will be happy to give more detailed information regarding marine installations.



Nghi Son, Vietnam: Marine outfall for the oil refinery, Weholite DN/ID 2700mm and 2025mm. The total supply included engineering and design, welding and profile filling, together with installation supervision.



Fos-sur-Mer, France: Cooling water pipelines for a power plant were delivered as a turnkey project. Weholite pipes DN/ID 2200–2400mm were installed to a total length of 1260m. Installation length 206m, Ballasting inside the profile wall.

Cooling water intake and outfall for the Philippines' largest crude oil refinery. A turnkey solution in marine environment; 610 metre Weholite DN/ID 2400mm and 450 metre Weholite DN/ID 2200mm.



Talvivaara mine, Sotkamo, Finland: Uponor submerged a 250m long Weholite DN/ID 1600mm pipe as raw water intake pipe.



St. Petersburg, Russia: Wastewater treatment plant outfall pipe. Uponor delivered 1060m DN/ID 1200mm pipe and welding services to this project.



Fos-sur-Mer, France: Weholite is one of few pipes in the world available in sizes above DN/ID 2000mm.

## Low-pressure pipelines



Helsinki, Finland: In the summertime the power plant cooling water PE pipeline conveys excess energy to the sea. In the wintertime, cold sea water is led through the pipeline to district cooling. For this project, more than 600m DN/ID 2000mm Weholite pipe from pressure class 1.5 bar was installed, including a dozen flange joints and numerous special fittings.



St. Petersburg, Russia: Weholite pipes DN/ID 2000mm were installed as outfall pipeline for a wastewater treatment plant. Of the 1400m length, 200m is marine pipeline. Weholite was also used in the starting end of the pipeline, at railway crossings and to extend old steel-, and concrete pipes. Additionally, several hundred metres of DN/ID 50 – 2000mm PE and Weholite pipes were delivered to the site.



Aberfeldie, B.C., Canada: During the renovation project for the Aberfeldie Run-of-River hydroelectric power plant, 855m DN/ID 3000mm Weholite pipe, PN 1.5 bar was installed as well as 14 bends and 2 manholes DN/ID 1200mm.

## Special constructions



As part of a joint project Uponor Infra was assigned to develop, design and install an infratunnel that contains media for potable water, waste water, electricity, telecommunications, heating and cooling for a new housing area in Linköping, Sweden. The 1.8km long tunnel was made of Weholite DN/ID 2200mm.



Gibraltar: Specially designed Weholite structures were installed for a stormwater discharge project.



St. Petersburg, Russia: The new discharge pipe for the south-west treatment plant is a Weholite DN/ID 2000mm pipe, total length 550m. The pipe was connected to the existing pipe with a diffuser made from Weholite pipe welded to the outermost part with 2.5m c:c intervals.



Philippines, intake tower



Great Britain: A prefabricated fitting DN/ID 3000mm is part of a stormwater retention tank solution with a total volume of 300m<sup>3</sup> and weight less than 5 ton. The installation including civil works took two days. Compared with traditional methods, Weholite saved several weeks installation time as well as the neighbor's patience.

## Tanks



Lumijoki, Finland: An alkalization plant in connection with a groundwater source ensures the correct pH-value for the drinking water and prevents corrosion in network components. The prefabricated system is quick and easy to install.



Iisalmi, Finland: An insulated aeration tank removes excess carbon dioxide from the water. The prefabricated DN/ID 2400mm tank was installed above-ground on a concrete slab.



Alaveteli, Finland: Weholite tanks DN/ID 3000mm offer a hygienic, long-lasting and economic alternative for storage of animal feed. These farm feed silos are the first of their kind made of polyethylene.



The village of Båtstø in Hallangen, Norway stepped boldly into a new era of green self-sufficiency when a WehoPuts 1020 waste water treatment plant was installed in the village. The treatment plant consists of three large 19-metre long tanks DN/ID 2400mm plus a distribution tank DN/ID 1600mm, all made of Weholite.



A stormwater retention tank for the energy company Vantaa Energy in Finland. The tanks were made of Weholite pipes DN/ID 3000mm in lengths of 20m. These 20-metre pipes were welded on-site to two tanks of 100 metre each.



Low water tank, 100 m<sup>3</sup> in Raippaluoto, outside Vaasa, Finland. Diameter DN/ID 3000mm and length 18 metre.



Kitilä, Finland: The WehoPuts 400 wastewater treatment plant built for the Kaukonen village was found the most rational solution when compared with transporting sewage or building a pumped transmission pipeline several tens of kilometres long. The treatment sludge can be composted on the treatment plant premises.

# Products, dimensions

## Pipes

Weholite pipes are manufactured in accordance with the product standards EN 13476, ISO 21138 and SFS 5906. The pipes have been awarded the Scandinavian quality mark INSTA-CERT N:o 4075.

### Socket Weholite

Size $d_n$	DN/ID mm	Do mm	M mm
315	280	364	155
400	360	458	175
450	400	508	175
560	500	622	195
675	600	732	225
788	700	845	240
900	800	957	270
1125	1000	1185	295

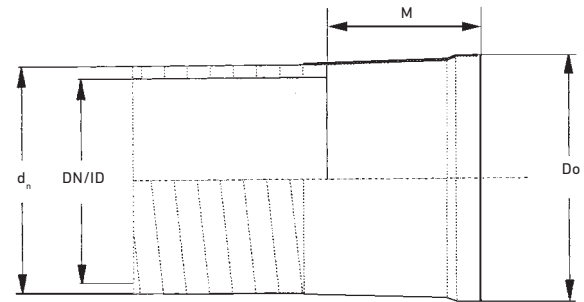

Dimension range DN/ID 280 – 1000mm

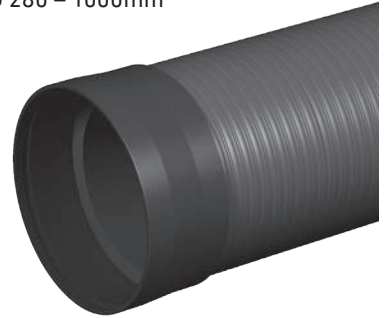

### Thread Weholite

Size $d_n$	DN/ID mm	l mm
400	360	50
450	400	50
560	500	65
675	600	77
900	800	90
1125	1000	100
1325	1200	120
1575	1400	130
1680	1500	130
1792	1600	130
2016	1800	180
2240	2000	190

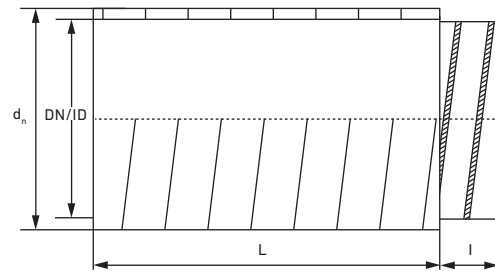

Dimension range DN/ID 360 – 2000mm



- DN/ID = nominal size = internal diameter
- $d_n$  = nominal outside diameter
- Do = maximum socket outside diameter
- M = Socket insertion depth
- L = Standard (useful) length 6 and 12m
- l = Thread length

Note! Dimensions are nominal values for SN4 (kN/m<sup>2</sup>) stiffness pipes and may vary from the finished product. The length tolerance L for pipes is  $\pm 50$ mm (+23°C). Pipe dimensions, stiffness classes and lengths for special applications can be individually designed.

# Bends

## Bends 1-45°

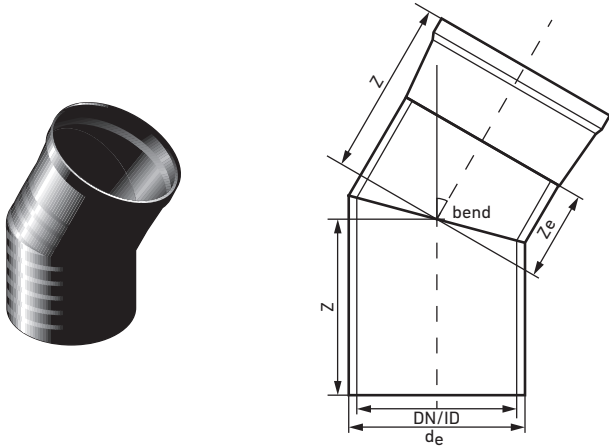

## Bends 46-90°

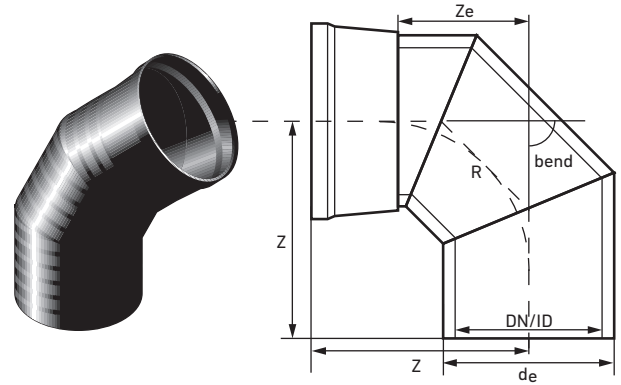

DN/ID mm	d <sub>e</sub> mm	Bends 1-45°				Bends 46-90°			
		30° Z mm	Ze mm	45° Z mm	Ze mm	60° Z mm	Ze mm	90° Z mm	Ze mm
280	315	270	108	326	157	372	195	535	313
360	400	322	137	386	201	433	248	586	401
400	450	329	154	400	225	453	278	622	447
500	560	391	191	480	280	546	346	757	557
600	675	450	231	556	337	636	417	889	670
700	788	510	270	633	393	727	487	1022	782
800	900	559	308	700	449	807	556	1145	894
1000	1125	651	385	827	562	960	695	1383	1117
1200	1325	781		993		1152		1659	
1400	1575	911		1158		1344		1936	
1500	1680	975		1240		1439		2073	
1600	1792	1040		1323		1535		2211	
1800	2016	1170		1488		1727		2488	
2000	2240	1300		1653		1919		2764	
2200	2464	1430		1819		2111		3041	

$$R = 1.0 \times \text{DN/ID mm}$$

Note! Dimensions are nominal values and may vary from the finished product. The tolerances for the dimensions Z and Ze are  $\pm 50\text{mm}$  (+23°C). The angle tolerance is  $\pm 2.5^\circ$ . Angles and bending radii for special applications can be individually designed.

Bends for sizes above DN/ID 2200mm are individually designed.

## Equal tees

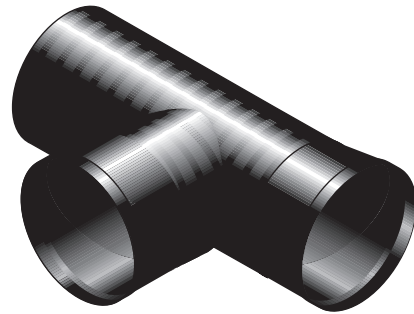
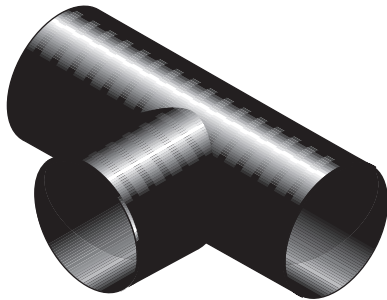
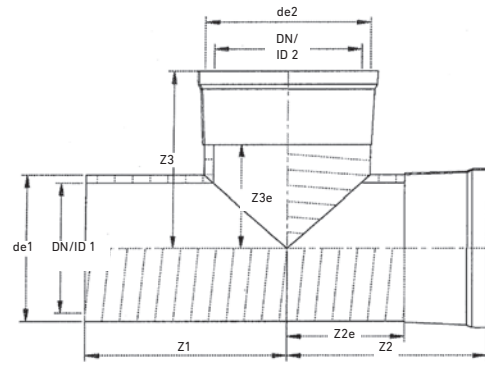
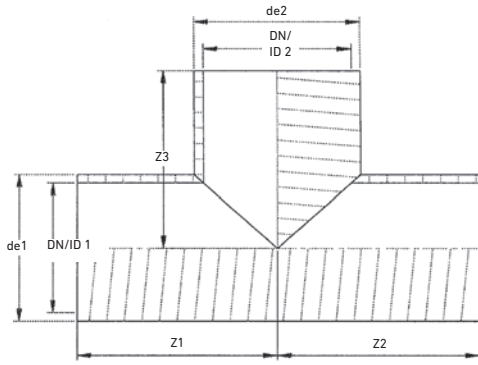

DN/ID = DN/ID2 mm	De1= De2 mm	Z1= Z2= Z3 mm	Z2e; Z3e mm
280	315	390	206
360	400	450	263
400	450	470	294
500	560	565	366
600	675	660	441
700	788	755	514
800	900	840	588
1000	1125	1000	735
1200	1325	1200	
1400	1575	1400	
1500	1680	1500	
1600	1792	1600	
1800	2016	1800	
2000	2240	2000	
2200	2464	2200	

Note! Dimensions are nominal values and may vary from the finished product. The tolerances for the dimensions Z and Ze are  $\pm 50\text{mm}$  (+23°C). For tees (DN/ID2 < DN/ID1), the dimensions Z3 and Z3e are as according to the table.

Tees for sizes above DN/ID 2200mm are individually designed.

## Double sockets

DN/ID mm	d <sub>e</sub> mm	L mm	Do mm
280	315	420	364
360	400	460	452
400	450	515	502
500	560	530	613
600	675	600	723
700	788	650	839
800	900	690	955
1000	1125	710	1185

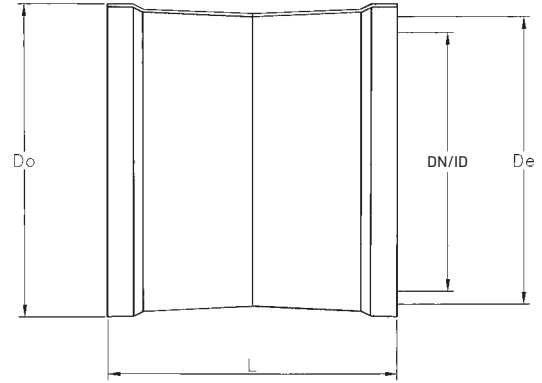

Note! Dimensions are nominal values and may vary from the finished product. The length tolerance is  $\pm 50\text{mm}$  (+23°C).



## Flange joints

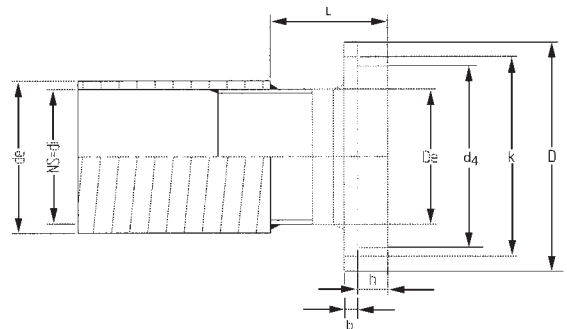
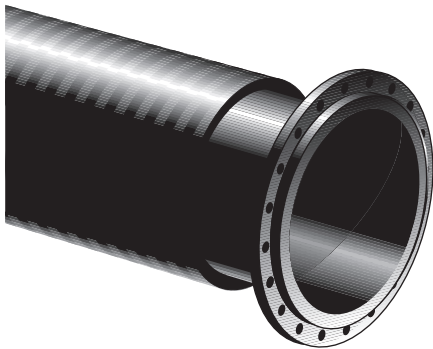

Joint DN mm	Weholite		PE pipe		Flange			Bolts		Stub end	
	DN/ID mm	d <sub>e</sub> mm	d <sub>e</sub> mm	L mm	D mm	b mm	k mm	pcs × size	Torque Nm	h mm	d <sub>4</sub> mm
350	360	400	355	377	505	30	460	16 × M20	45	40	430
400	400	450	400	385	565	34	515	16 × M24	60	44	482
500	500	560	500	379	670	38	620	20 × M24	70	47	585
600	600	675	630	390	780	40	725	20 × M27	80	56	685
700	700	788	710	400	895	45	840	24 × M27	90	60	805
800	800	900	800	415	1015	53	950	24 × M30	100	77	900
1000	1000	1125	1000	438	1230	62	1160	28 × M33	130	96	1110
1200	1200	1325	1200	460	1455	68	1380	32 × M36	180	100	1330
1400	1400	1575	1400	480	1675	80	1590	36 × M39		105	1535
1600	1600	1792	1600	491	1915	100	1820	40 × M45		110	1760

Note! Dimensions are nominal values and may vary from the finished product. Flanges are drilled according to DIN 2501, PN10.

## Wall anchoring

A separate, waterproof fitting is to be used when installing the pipeline through a fixed wall structure.

Note! To minimize shearing forces, it is recommended to install a rubber sleeve or similar between the pipe and wall. The backfill compaction shall also be done carefully.

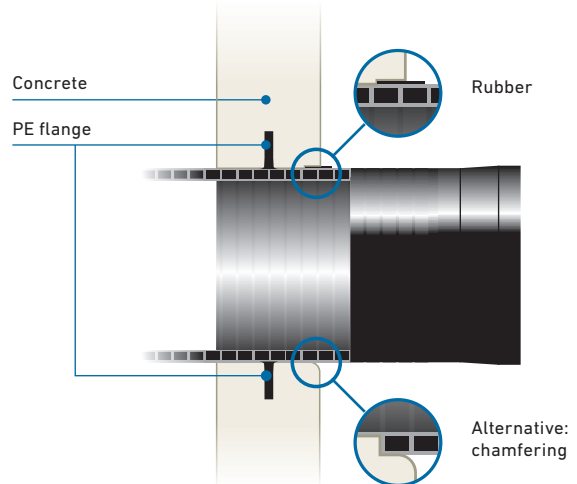
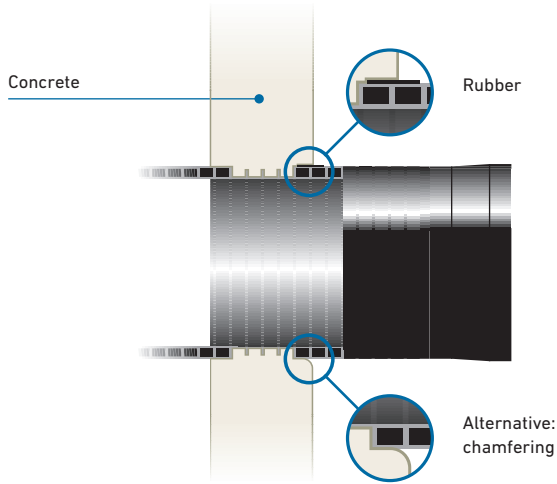

## Manholes

The Weholite pipe system includes a comprehensive selection of manholes. Manholes are normally prefabricated. Connections, heights, covers and so on are done according to the client's wishes. Typically the manholes are standalone, but inspection manholes can be built as saddle manholes directly on top of the pipeline. Saddle manholes can be prefabricated or installed at the jobsite.



### Typical types of manholes:

Stormwater manhole

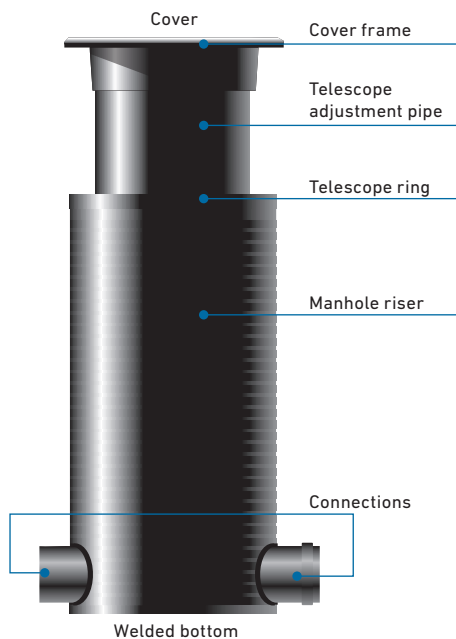

Saddle manhole (inspection pipe)

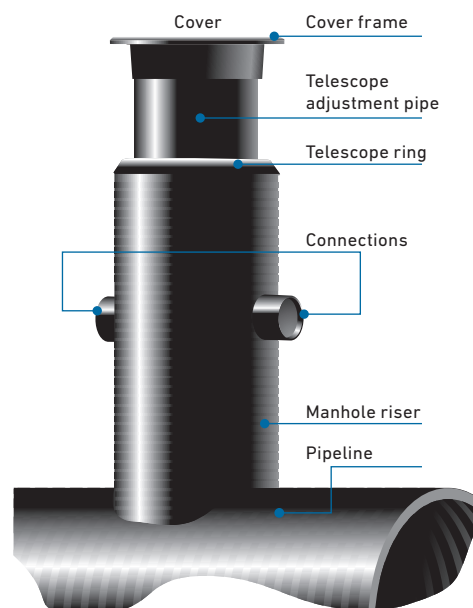

# Design, installation

## Material properties

### Chemical resistance

For all practical purposes, PE is chemically inert within normal use. In other words, PE does not rot, rust or corrode as a result of chemical or electrical reactions in any soil type, nor does it release or dissolve anything into the soil. More information on the chemical behavior of PE is given in ISO 10358.

### Typical physical properties for Weholite pipe and resin

Property	Value	Unit	Standard
E-modulus, short term	≥ 800	MPa	ISO 527
Density	≈ 940	kg/m <sup>3</sup>	ISO 1183
Linear expansion coeff.	≈ 17·10 <sup>-5</sup>	K <sup>-1</sup>	
Thermal conductivity	≈ 0.36–0.50	W/(K · m)	
Specific heat capacity	≈ 2300–2900	J/(kg · K)	
Surface resistance	> 10 <sup>13</sup>	Ω	
Poisson ratio	0.45	(-)	
Tensile strength	> 15	MPa	ISO 6259
Elongation at break	> 350	%	ISO 6259

### Temperature range

The maximum allowable temperature of the pipe medium:

Material	Short term temperature	Long term temperature
PE	+80°C	+45°C
PP	+95°C	+50°C

Please contact your local Uponor representative for more detailed information on allowable operating temperature.

## Hydraulic design

### Partially water-filled pipes

Diagram giving the change of water flow volume, filled area, flow velocity and hydraulic radius as functions of the filling level in the pipe. The 10Q curve illustrates an enlargement of the Q curve between 0 and 12% on the horizontal axis.

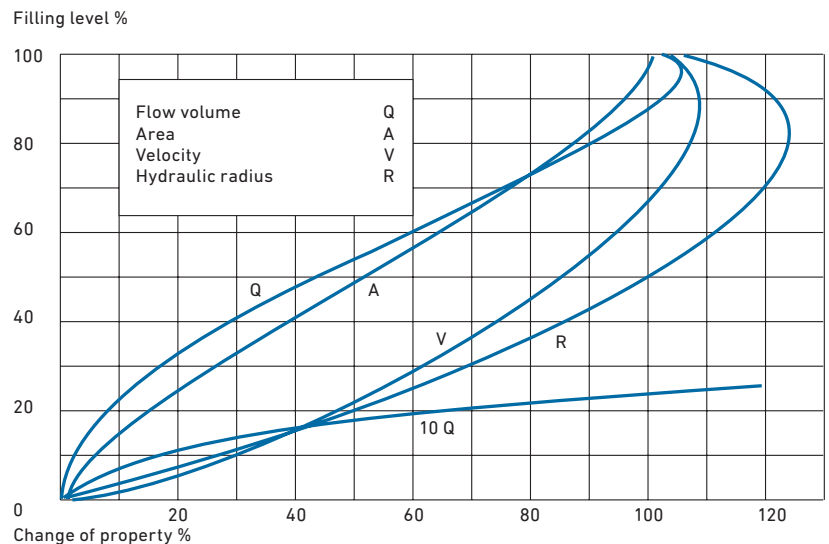

### Abrasion resistance

In the so-called Darmstadt abrasion test (DIN 19534, part 2), pipe samples are filled with a mixture of sand and water, and then subjected to a specified number of rocking cycles. The amount of abraded material is measured at regular intervals. Results indicate a very high abrasion resistance for PE pipe materials.

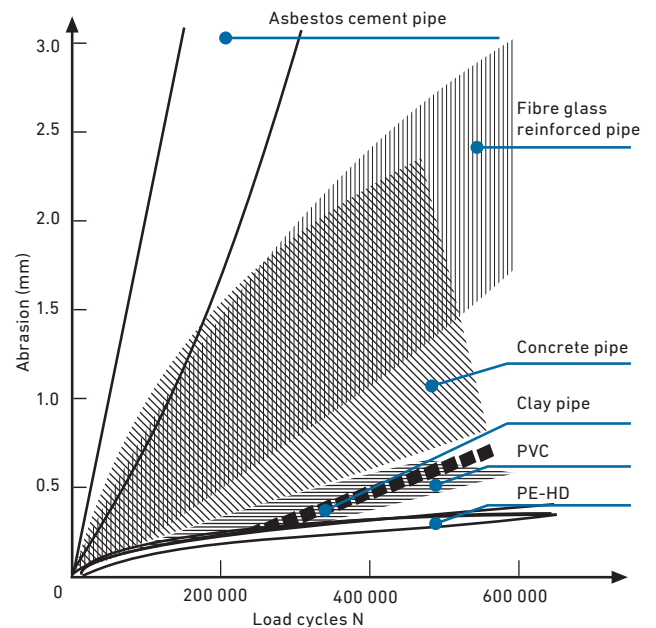

### Discharge nomogram for pipes flowing full

The pipe roughness coefficient is 0.03. In this nomogram, a system roughness coefficient of 0.25 is assumed.

Kinematic viscosity of water at +10°C.

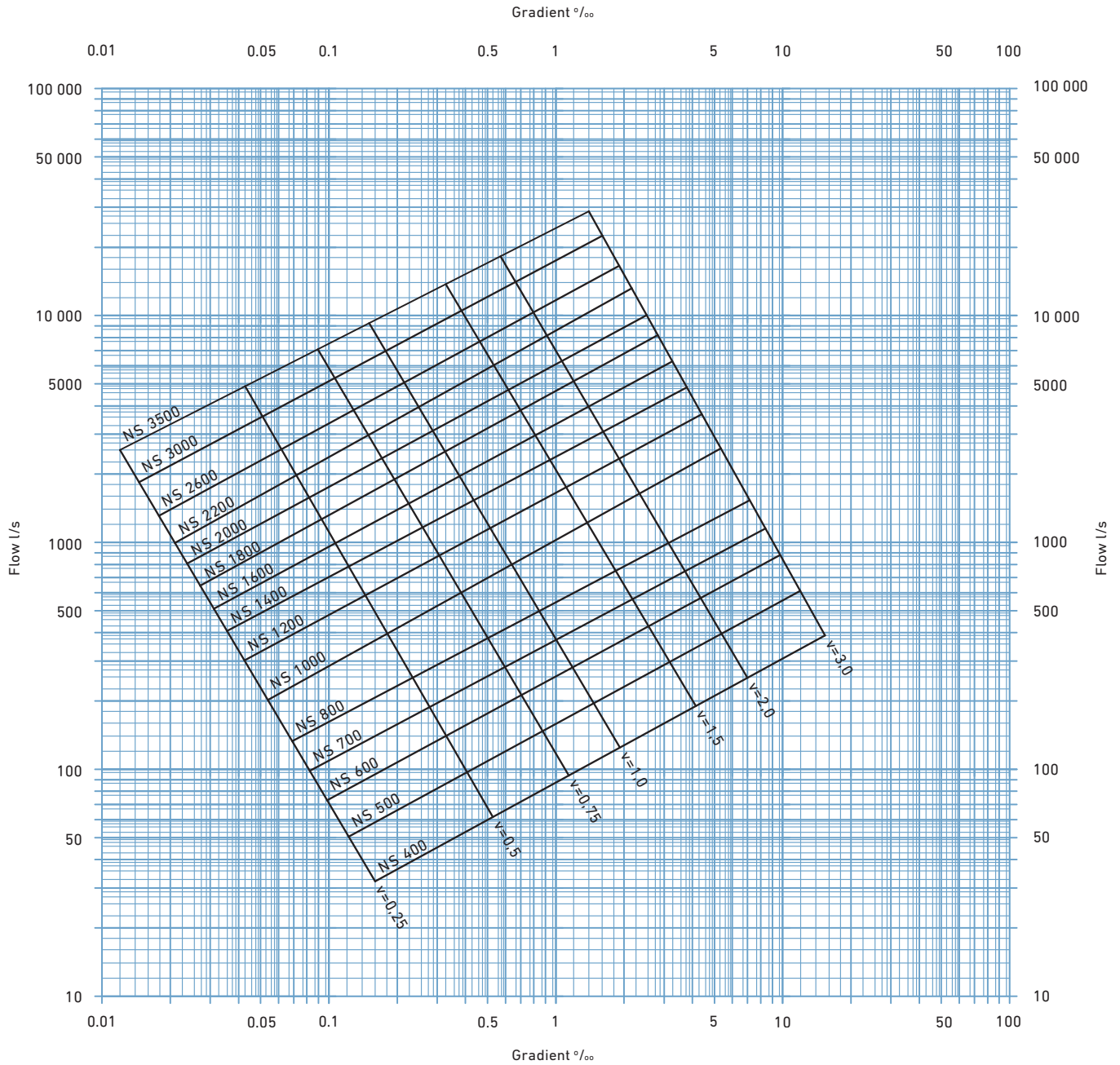

# Structural design

## Flexible buried pipelines

A flexible pipe like Weholite is by definition a pipe which will deflect when subjected to external loads (traffic, ground water changes, frost actions, soil settlement etc.) – as opposed to a rigid pipe which carries all external loads by itself. The degree of deflection of a flexible pipe will depend on the pipe stiffness, support from the surrounding soil, and on external loads.

There are several methods for calculating the deflection in buried flexible pipelines. Most of them are based on the so-called

### Spangler formula:

$$\text{deflection (\%)} = \frac{\text{vertical load on the pipe}}{\text{pipe stiffness} + \text{soil stiffness}}$$

The bulk of the deformation is caused during backfilling of the trench. After installation, further compaction of the surrounding soil develops with time due to external loading and soil settlement. Experience shows that the maximum deflection will be achieved within 1 – 3 years after installation, depending on backfill material, quality of backfill compaction work and on external loads. The maximum allowable deflection is 5 – 10% depending on national regulations.

Field experience and investigations show that installation varies along the pipeline. This variation reflects differences in support and external loading on the pipe. The installation variability results in variations in deflection for flexible pipes and variations in bending moments for rigid pipes.

A flexible pipe absorbs external loads and deforms to a certain extent. A rigid pipe, on the other hand, by definition cannot deform. When external loads increase sufficiently, the rigid pipe will finally crack and lose its stiffness.

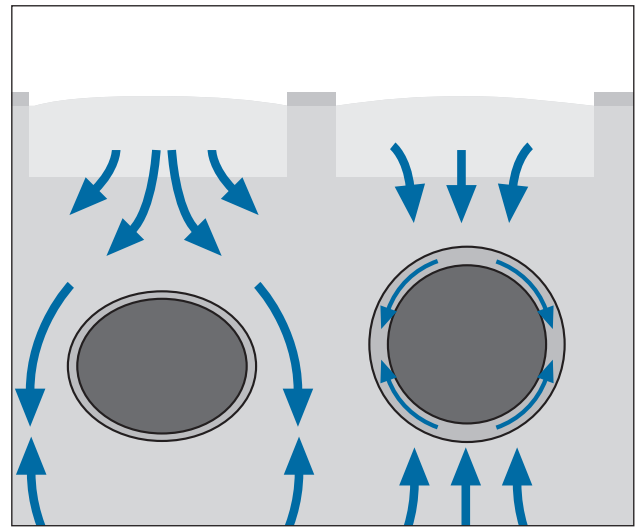

Flexible pipe

Rigid pipe

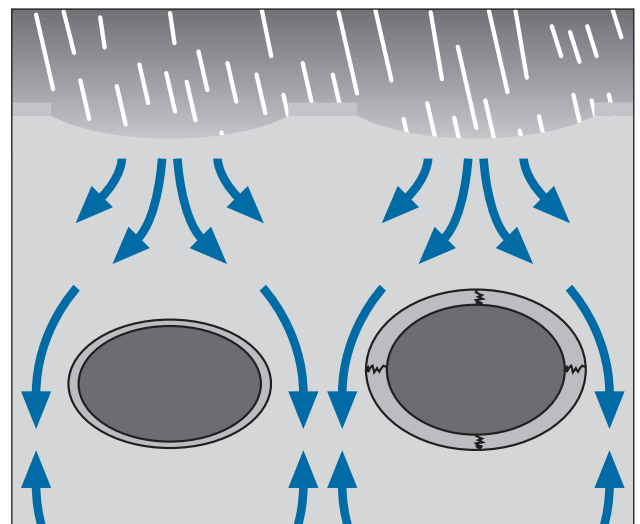
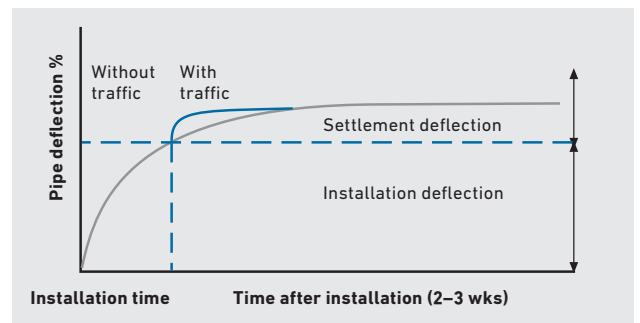

Flexible pipe

Rigid pipe

## Buckling resistance

The main type of failure which could occur in a thermoplastic pipe is collapse (buckling) due to overloading. This design criterion should therefore be checked even though rarely this will determine the choice of pipe ring stiffness.

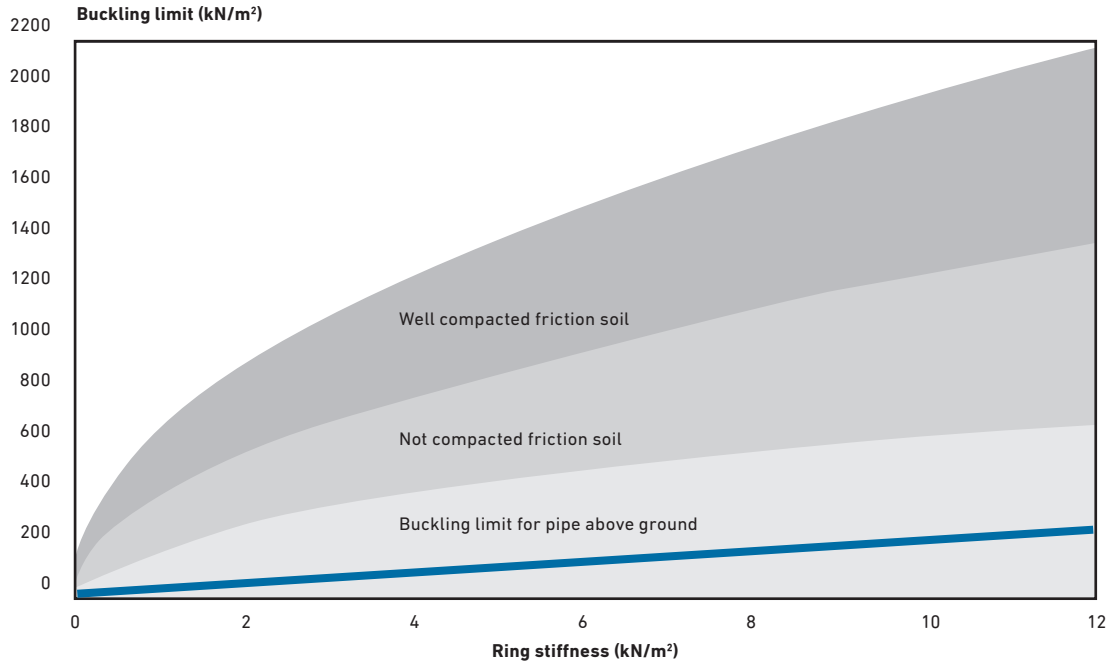

For a pipe with ring stiffness at least SN4 kN/m<sup>2</sup>, the buckling risk needs to be checked only if the installation depth is more than 6m.



Helsinki, Finland: At the roundabout on the Ring 1 main road, the cover depth is only 400mm. Weholite SN4 DN/ID 1600mm, 2 parallel culverts.



Degerfors, Sweden: Railway culverts Weholite DN/ID 1800mm, 2 × 24m.

## Design graph for pipe selection

Based on a study by Teppfa (Design of Buried Thermoplastics Pipes; 1999), several design approaches can be proposed. Designs can be kept simple thanks to the strainability of thermoplastics pipes. It was concluded that the most focus should be put into the installation/backfilling of the pipe. It is also important to remember that flexible pipes follow the soil settlement. Under the scope of the investigation, load is therefore not an issue for flexible pipes. Based on the results of this work, the design approach using a simple graph is strongly recommended.

In the design, graph areas are given for each installation group.

The lower boundary of each group represents the average deflection expected after installation and the upper boundary the maximum.

The design graph contains three installation groups. Consolidation factors (Cf) have to be added to the initial deflection values, obtained from the graph.

**Note:**

- installation depth 0.8 - 6 m
- pipes fulfill relevant EN or ISO product standard requirements
- heavy traffic load
- allowed deflection for PE pipes is 8 - 10%

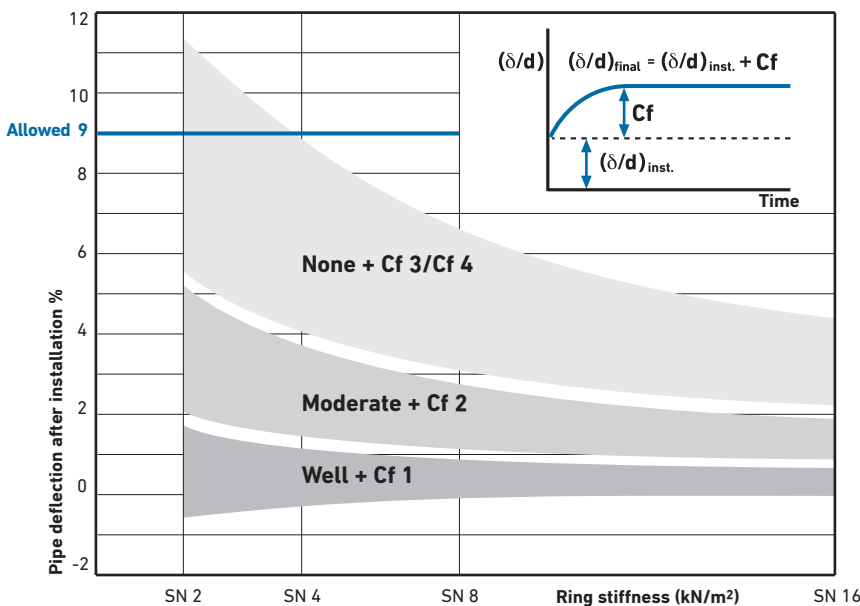
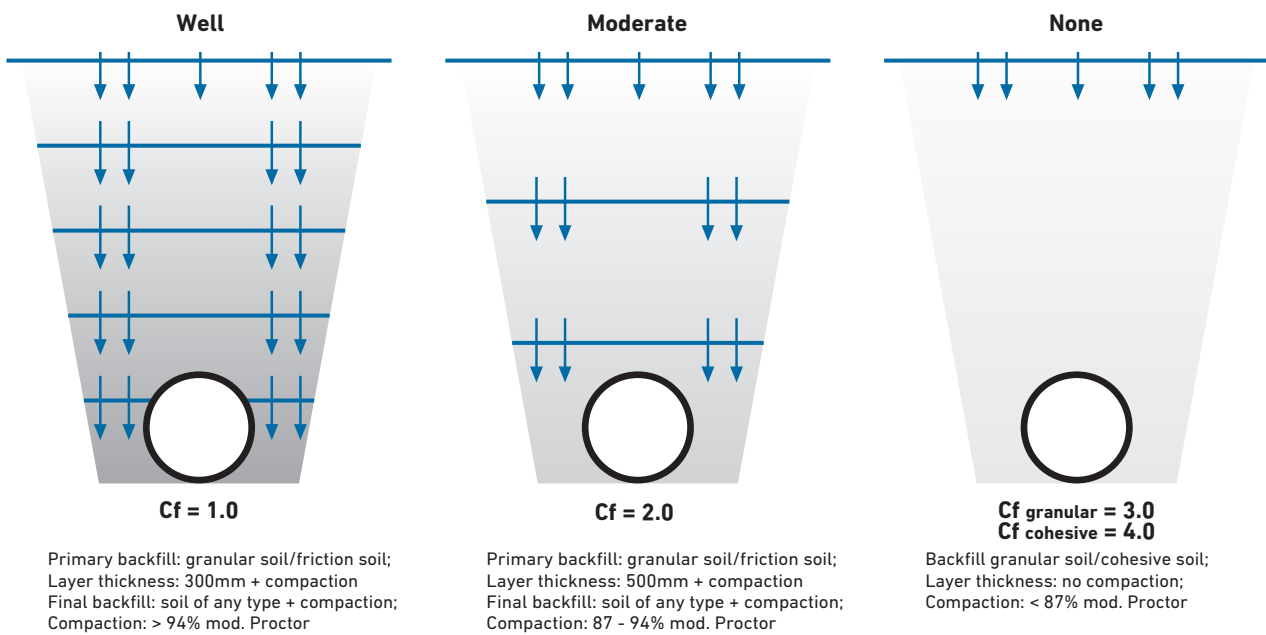

Cf = consolidation factor  
 $\delta/d$  = deformation  
 Source: TEPPFA (1999),  
 Design of Buried  
 Thermoplastics Pipes

## Trench works

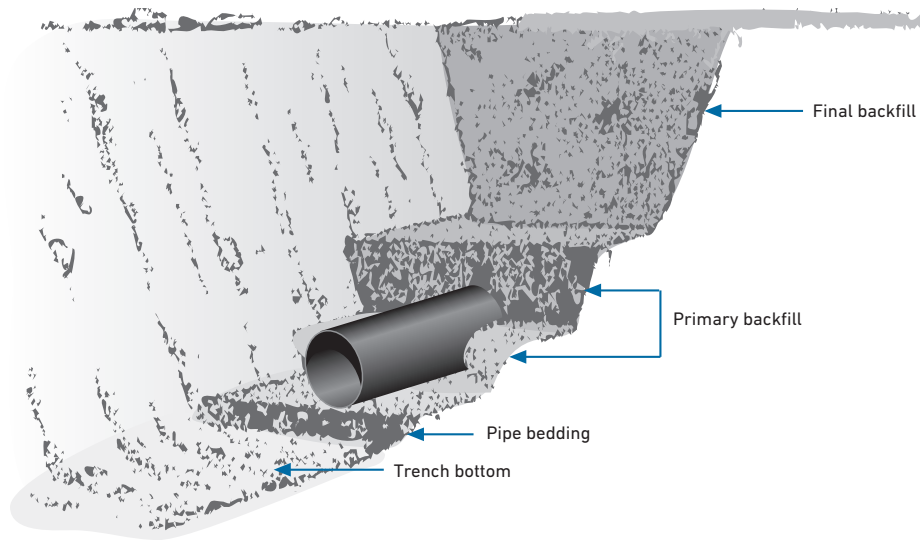

Please refer to national codes of practice for installation of plastic pipes wherever applicable.

### Pipe bedding

The bedding soil shall be free from stones within the width of the pipe trench. On the trench bottom, a 100-150mm thick bedding layer is prepared and well compacted mechanically. The bedding shall be at least 400mm wider than the pipe outside diameter. For installations in soft/wet soil, a geotextile is placed under the bedding to keep bedding and native materials separate.

### Primary backfill

The primary backfill material shall be a friction soil or macadam. Backfilling shall be made over the whole width of the trench. Compaction of the backfill material shall be made in layers of 150-300mm. The final layer of the primary backfill shall extend 300mm above the pipe crown.

The primary backfill material is carefully spread from a low height. The haunch area compaction is to be made with special care, making sure the pipe does not move. The primary backfill is made in even layers on both sides and in the lengthwise direction of the trench. Frozen soil material shall not be used.

Note! No compaction is to be done directly above the pipe until the backfill has reached 300mm above the pipe crown.

### Final backfill

Requirements for the final backfill material are different for traffic load areas and non-traffic load areas. Compaction is carried out in several layers. The final backfill material shall be compactable as dug materials or better. The material must, however, be free from stones.



## Bending

Changes in the alignment of sewer pipelines are normally done in manholes or using bends. Small alignment changes can be accommodated by bending the pipe itself. When bending socketed pipes, the bending may not be at the socket. The minimum permissible permanent bending radius for Weholite pipes under normal installation conditions is  $R = 100 \times d_e$  (outside diameter). During installation, smaller bending radius values are acceptable, down to  $50 \times d_e$ . An acceptable bending radius can be maintained by lateral supports against the side of the trench. For practical reasons, bending pipe with DN/ID > 1500mm in field conditions can be difficult. Special care should be taken when bending pipes at low temperatures. Uponor representatives will be happy to assist with any questions regarding bending.

### Support spacing, m

- sag 10mm/10 years
- liquid density 1000kg/m<sup>3</sup>

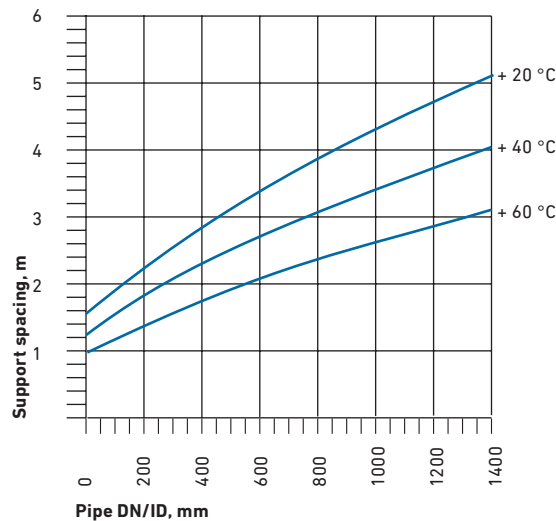

## Support spacing

For above ground installations, the maximum support spacing can be determined according to the figure on the right.

## Buoyancy

When installing pipes under the ground water level, the buoyancy of the pipe shall be taken into consideration. When needed, the natural uplift of the pipe should be counteracted. This can be designed case by case. Please do not hesitate to contact our nearest office for adequate technical information.

### Buoyancy of Weholite pipes

DN/ID mm	D <sub>n</sub> mm	Pipe empty Profile empty kN/m	Pipe full Profile empty kN/m	Pipe full Profile full N/m
360	400	1.23	0.24	10
400	450	1.52	0.29	10
500	560	2.38	0.45	10
600	675	3.43	0.65	10
700	790	4.66	0.89	20
800	900	6.09	1.16	20
1000	1125	8.97	1.27	30
1200	1350	13.70	2.61	40
1400	1575	18.65	3.55	50
1500	1680	21.41	4.08	60
1600	1792	24.36	4.64	70
1800	2016	30.83	5.87	90
2000	2240	38.06	7.25	110
2200	2464	46.05	8.78	130

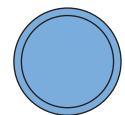
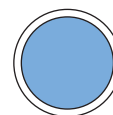
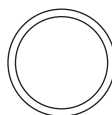

# Jointing

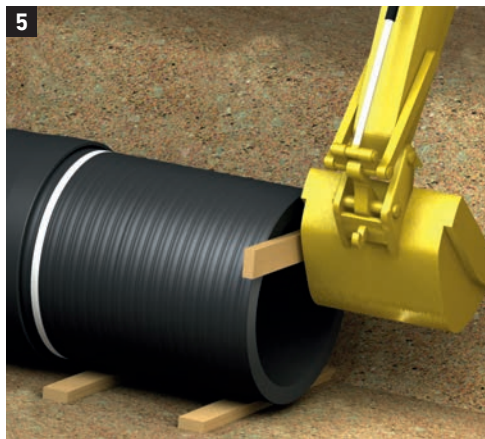
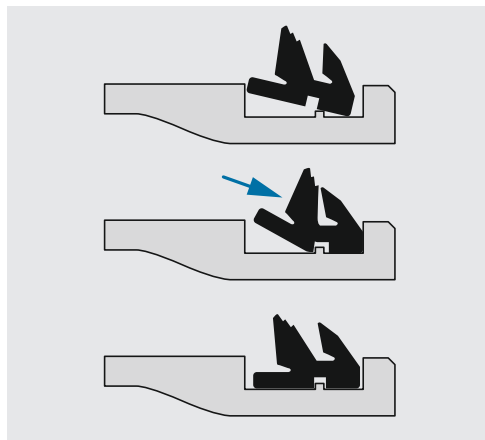
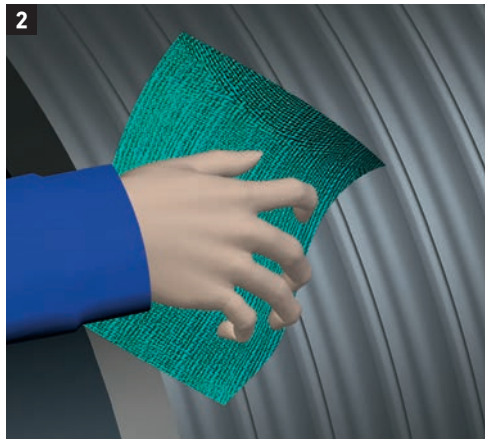
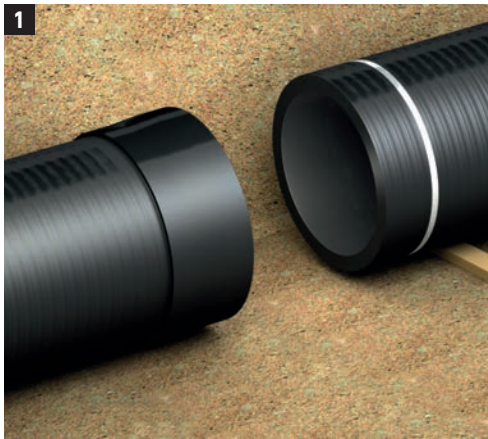

## Socket joint

1. Align the pipes vertically and horizontally. To help with the alignment, the spigot end can be raised by placing for instance a plank under it.
2. Make sure that spigot end, socket and sealing ring groove are clean from sand, moisture, dust etc.
3. Apply sealing lubricant/grease evenly onto the sealing ring groove and sealing backside, and install the rubber sealing into the groove. Ensure the sealing is seated the correct way and smoothly around the circumference.
4. Apply lubricant evenly onto the spigot end and the sealing inside.
5. Measure the correct insertion length and mark it into the spigot end, if it is not already done. Gently push the spigot into the socket using adequate force until the insertion length mark is at the socket opening. Use a plate or plank to avoid damage to the spigot or socket. Larger dimensions can be installed by using an excavator. Protect the socket opening with a sheet or plank. Observe that the sealing ring stays in position. Remove planks and other aids after installation.

## Rubber sealings

Socket joints are sand tight. A separate rubber sealing is used when water tightness is required. The rubber sealings are sewage proof, not including oil or solvents. The rubber sealings meet the requirements of EN 681. Oil-resistant sealings are available on request.

## Heat shrink sleeves

Heat shrink sleeves can be used for example for plain pipe ends with thread joints to provide water tightness; and for connections to other materials. Special sleeves can be ordered on request.

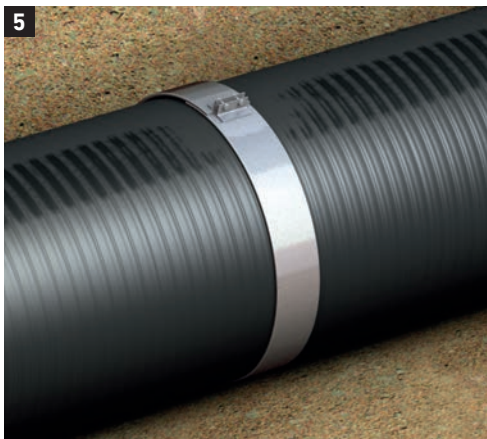
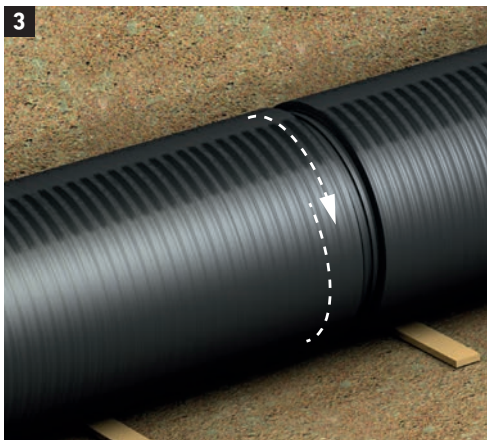
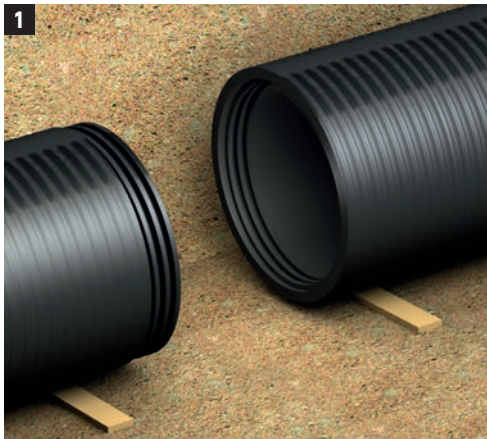

## Thread joint

1. Make sure that the threads are clean from sand, moisture, dust etc.
2. Align the threads vertically and horizontally. The pipes will start to join immediately when the threads connect.
3. Thread the male end into the female end.
4. The pipe can be rotated using a lever or rope-sling. If needed, an excavator can be used to help rotate the pipes. To facilitate the rotation, the pipes can be laid on planks or roller supports which are removed after installation.
5. The joint as such is sand-tight. If water-tightness is required, the joint can be extrusion welded from the inside (NS > 800mm), from the outside, or both. The joint can also be water-proofed using an external shrink sleeve or rubber sleeve.

## Extrusion welding

Extrusion welded joints are fully watertight and resistant to tensile forces. Extrusion welding is carried out with appropriate equipment by experienced personnel. Uponor Infra has developed suitable welding machines to be used either from the inside or outside of the pipeline.

## Sleeve joints

Sleeve couplings are designed for joining pipes in sewerage and other non-pressure applications in the construction, repair or maintenance of pipelines.

- As a joint for plain ended pipes
- Repair of existing pipelines
- As an adaptor between pipes of different sizes or materials
- When joining pipes of different sizes to each other

## Jointing methods



Heat shrink sleeve installation



Internal extrusion welding machine. All works are to be carried out by experienced personnel.



Welding seam covering the full profile height.



Hand-held extrusion machine. Hand extrusion is especially suited for waterproofing thread joints.



External welding machine

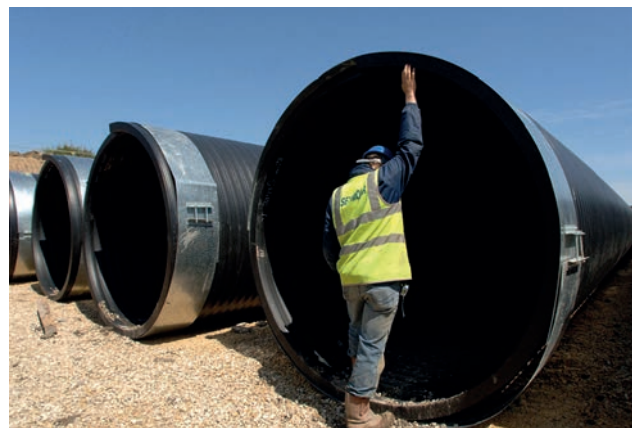

Sleeve joints

# Handling, transportation and storage

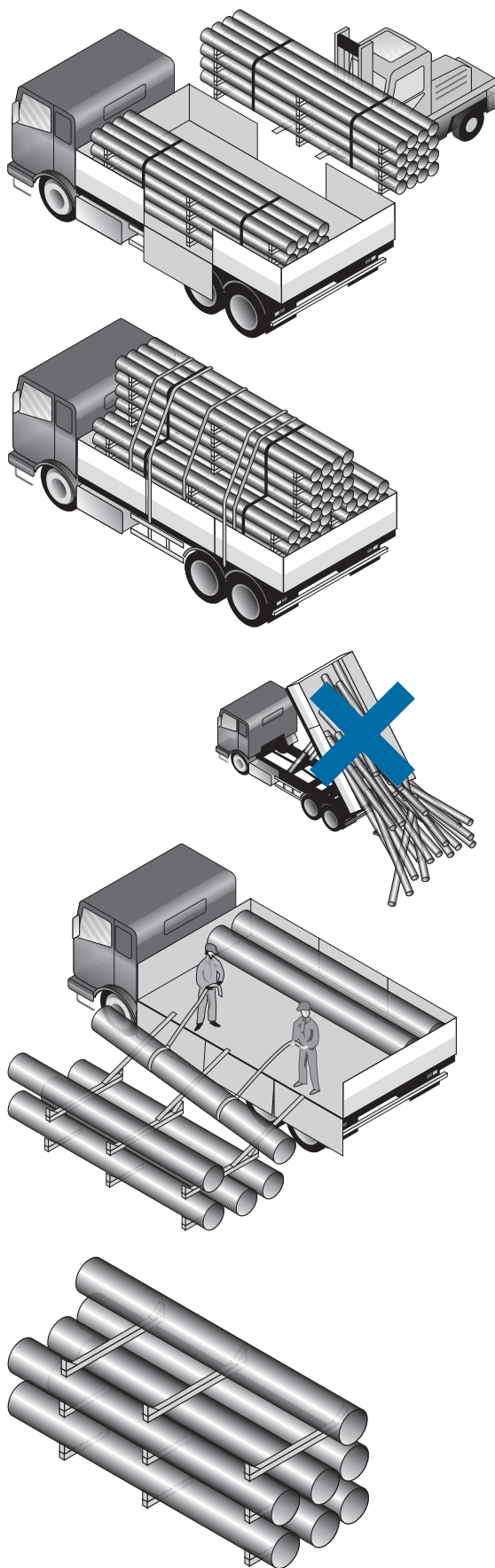

## General

Handling should be done carefully and dragging of pipes, fittings and manholes must be avoided. Weholite pipes and fittings become slippery in wet or in cold weather. It is not recommended to handle pipes and fittings at temperatures below  $-20^{\circ}\text{C}$ . Pipes, fittings and manholes must be transported and stored in their own packages. Protective packaging shall be removed immediately before installation.

## Loading

Never drop the pipes, fittings or manholes. Lifting points shall be well spread and evenly spaced. Use proper lifting slings. Chains or end hooks shall not be used.

## Transport

Delivery vehicles shall be provided with a clean, flat bed, free from sharp objects. Care shall be taken to prevent slippage or bending of the pipes. Tie the load well to prevent rubbing. Use nylon straps or slings, not chains or ropes. Pipes or fittings must not rest on their sockets. Avoid contamination from diesel oil and similar substances.

Off-loading on site may be made easier by using skid timbers and strap slings.

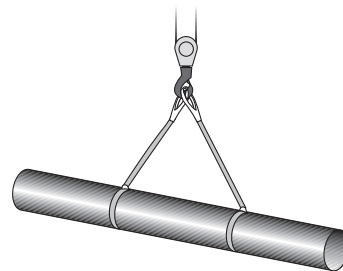

## Storage

All materials shall be carefully inspected at the time of delivery and any defects should be notified and reported immediately.

All pipe stacks shall be made on firm, flat ground to support the weight of the pipes and lifting equipment. For safety and convenience of handling, the stacking height for pipes shall be limited to five units, not more than 3 metres, and adequately wedged to prevent movement.

Pipes must be stored from timber to timber. Pipes with integral socket shall be stacked with the sockets free at alternate ends. Pipes and fittings shall be stored away from heat sources. When Weholite pipes are exposed to sunlight for a prolonged time, pipes shall be covered. Protect all materials and equipment from theft, vandalism, accidental damage or contamination.

# Quality control



Ring stiffness test



Lengthwise stiffness test for a DN/ID 600mm, SN4 pipe. Load 29kN, deflection 30mm, pipe deformation 54mm.



- Manufacturer or product name;
- Ring stiffness;
- Material (PE, PP, other);
- Dimension OD/ID;
- Production code;
- Approval mark if pipe has national or international approval.

Uponor Infra maintains a complete quality control from raw material to finished pipe product by establishing strict manufacturing specifications. Weholite production is ISO 9000 certified. The characteristics of Weholite pipes are determined by EN 13476, ISO 21138 and SFS 5906. The pipes have Nordic Poly Mark, INSTA-CERT approval 4075 for dimensions 300–1200mm.

## The Weholite quality control consists of:

1. Raw-material tests
2. Product geometry and tolerances
3. Product properties

Weholite pipe has national approvals in Finland, Sweden, the United Kingdom, Poland and Canada.

## Marking

Weholite pipes are marked in accordance with standard requirements in a clear and durable way, to maintain legibility for the life of the pipe under normal storage, weather conditions, and use. The pipe marking can be seen on the bottom picture.

## Environmental aspects

Uponor Infra appreciates environmental, health and safety interests as an important and inseparable part of its business. Uponor Infra strives to save energy and prevent waste; and recycles wherever waste cannot be avoided. Uponor Infra does not use materials which have been proven to be unacceptable for the environment, health and safety. Open minded and good relations to customers and to authorities are one of the important parts of our daily business.



# Site testing

## Site tightness testing on gravity pipes

(Summary of the Finnish standard SFS 3113)

### Principle

A delimited section of pipe is filled with water and subjected to a certain, small, overpressure. The tightness is controlled at the final stage of the test by determining the quantity of additional water needed to maintain the pressure. The test should be carried out from one manhole to the next with either the whole pipeline in plain sight or joints left uncovered to enable identification of possible leaks.

Before testing, the pipeline is cleaned. End plugs are supported to prevent movement during the test. The pipeline is filled with water with the air exhaust valve open. The necessary overpressure is dependent on the groundwater elevation. The groundwater elevation at the time of testing is assessed at the halfway point between manholes. The testing pressures are given in the table. Before commencing the test, the pipeline shall have been water-filled without pressure for at least 2 hours. The test shall not be performed if there is a risk of freezing.

Groundwater level above the pipe a (m)	Testing pressure $P_{e1}$	
	kPa	bar
$a < 0$	10.0	0.1
$0 < a < 5$	15.5	0.155
$0.5 < a < 1.0$	21.0	0.21
$1.0 < a < 1.5$	26.5	0.265
$1.5 < a < 2.0$	32.0	0.32
$2.0 < a < 2.5$	37.5	0.375
$2.5 < a < 3.0$	48.5	0.485
$3.5 < a < 4.0$	54.0	0.540
$4.0 < a < 4.5$	59.5	0.60
$4.5 < a < 5.0$	65.0	0.65

### Method

1. Increase the pressure to the testing level and monitor the tightness of the testing equipment. Hold the pressure for 10 minutes.
2. The testing pressure is maintained at the level  $P_{e1}$  during half an hour by adding water when necessary. Measure the volume of water added during three 6 minute intervals.
3. When the test is completed, the average volume of the added water is calculated. This volume is converted into functions of pipe length and time ( $l/m * h$ ), where
  - $l$  = litre of added water
  - $m$  = length of the pipeline in metres
  - $h$  = hour

The value obtained and the inside diameter of the pipe is inserted in the diagram below. All readings below the line are acceptable.

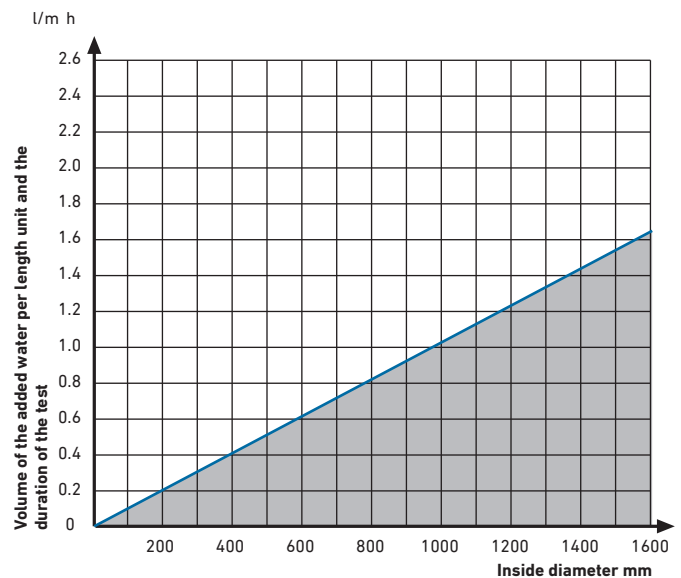

**Uponor Infra Oy**

P.O.Box 21

FI-65101 Vaasa, Finland

**T** +358 20 129 211

**W** [www.uponor.com](http://www.uponor.com)

**E** [asiakaspalvelu.fi@georgfischer.com](mailto:asiakaspalvelu.fi@georgfischer.com)

32014\_04\_2026 EN