

**Uponor**

# Uponor Ecoflex pre-insulated pipes

Technical information

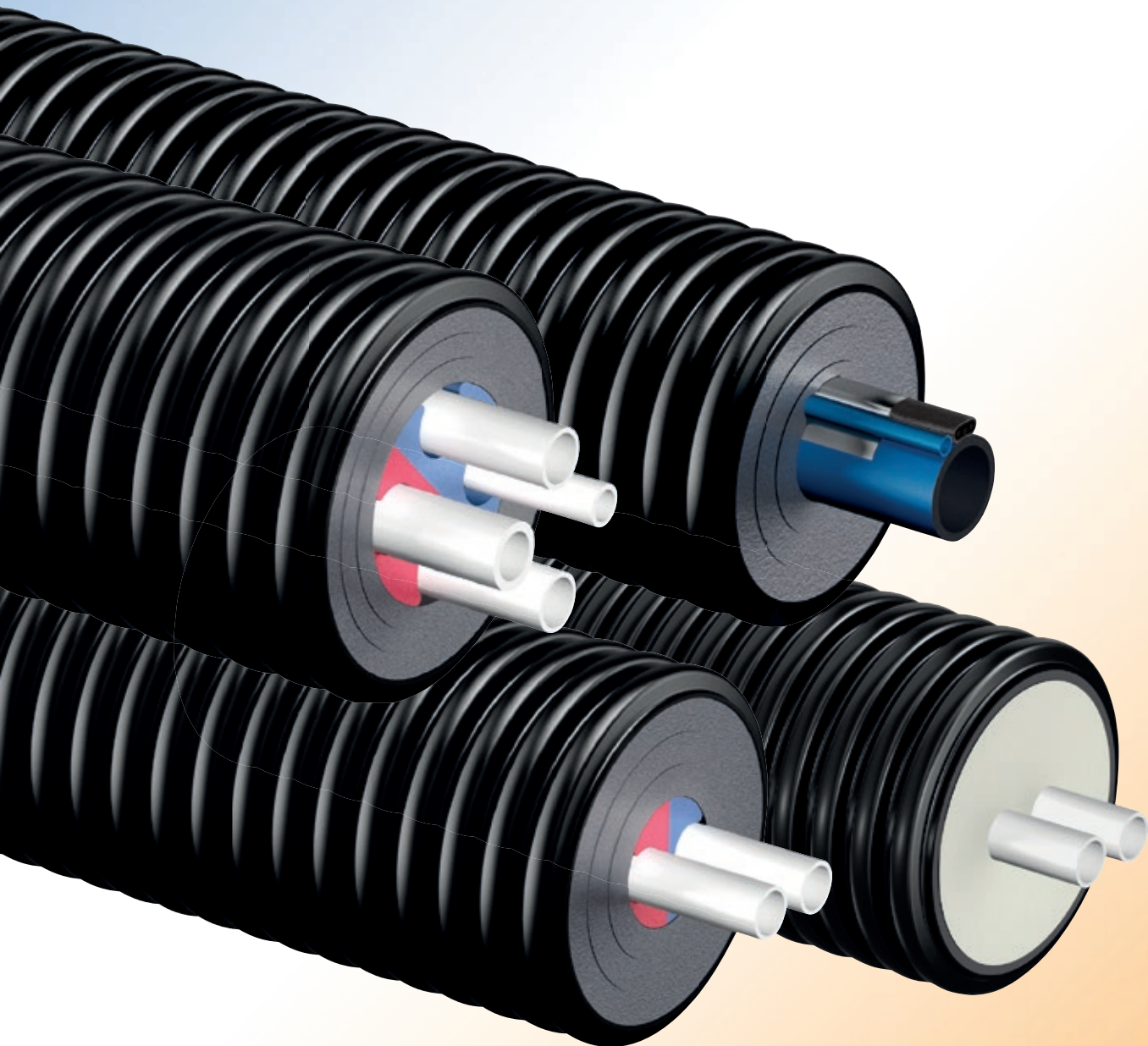

# Content

<b>System description and fields of use</b> .....	<b>3</b>	<b>Uponor Ecoflex Supra: reliability for cold water supply and cooling networks</b> .....	<b>78</b>
System description .....	3	Pipe design .....	78
Fields of use .....	3	<b>Uponor Ecoflex Supra PLUS: carefree living even in cold temperatures</b> .....	<b>80</b>
Quality, signed and sealed .....	4	Pipe design .....	80
<b>Product profiles</b> .....	<b>8</b>	<b>Uponor Ecoflex Supra PLUS: self-regulating cable and control unit</b> .....	<b>83</b>
<b>Uponor Ecoflex Thermo and Varia: flexibility and ease of installation</b> .....	<b>11</b>	Planning .....	86
Uponor Ecoflex Thermo .....	12	Installation .....	91
Uponor Ecoflex Varia .....	14	<b>Uponor Ecoflex Supra Standard: non-freeze water pipes for longer pipelines</b> .....	<b>98</b>
<b>Uponor Ecoflex Thermo PRO: energy efficiency</b> .....	<b>16</b>	Pipe design .....	98
<b>Uponor Ecoflex Aqua: the flexible specialist for warm tap water</b> .....	<b>19</b>	<b>Uponor Ecoflex Supra Standard: constant resistant cable and regulator 600S</b> .....	<b>101</b>
<b>Uponor Ecoflex Quattro: smart way to make single building connections</b> .....	<b>22</b>	Planning.....	104
<b>Design</b> .....	<b>24</b>	Installation .....	107
Design basics .....	25	<b>Uponor Ecoflex Supra Mantle: an insulated jacket for water pipe inlet</b> .....	<b>117</b>
Design the marked-out route .....	26	Pipe design .....	117
Installation examples .....	27	<b>Uponor Ecoflex Mantle: self-regulating cable</b> .....	<b>119</b>
<b>Dimensioning</b> .....	<b>31</b>	Installation .....	120
Pressure loss tables .....	32	<b>Technical specifications</b> .....	<b>121</b>
Dimensioning heating basics .....	38	Properties of the Uponor PE-Xa pipes .....	121
Quick dimensioning tables .....	39	Long-term properties .....	124
Heat loss .....	44	Material properties of the jacket pipe.....	125
<b>Installation</b> .....	<b>54</b>	Material properties of the insulation.....	125
Guideline values for the installation process .....	55	<b>Appendix</b> .....	<b>126</b>
Pipe handling .....	56	All technical and legal information contained in this catalogue has been carefully compiled according to the best of our knowledge. We cannot be held liable for any errors as these cannot be fully excluded. The technical guideline, including all sections, is protected by copyright.	
<b>Pressure and leak testing</b> .....	<b>60</b>	All uses beyond those permitted under the copyright law are not allowed without the approval of Uponor. This applies particularly to reproduction, re-prints, processing, storage and processing in electronic systems, translations and microfilming. The contents of the technical guideline are subject to change without notice.	
For heating pipes according to DIN 18380 .....	60	Copyright 2019	
For tap water application according to DIN 1988 Part 2 .....	62	Uponor	
<b>Product line components</b> .....	<b>64</b>		
Uponor Wipex fitting range .....	64		
Uponor Ecoflex coupling for 125 mm .....	66		
Uponor Q&E PPSU fitting range.....	67		
Uponor Ecoflex jacket joint set .....	68		
Uponor Ecoflex rubber end caps .....	69		
Uponor Ecoflex insulation sets .....	70		
Uponor Ecoflex house connection elbow Single/Twin .....	71		
Uponor Ecoflex chamber .....	72		
Uponor Ecoflex wall ducts .....	74		
Additional accessories .....	76		

# System description and fields of use

## System description

From practice - for practice. This is the fundamental idea behind our flexible, pre-insulated piping systems. The flexibility of the material, the convenient connecting methods and the well-attested service life and robustness of our pre-insulated pipes ultimately ensure that the projects can be completed quickly, economically and reliably. Just the same, whether it's about an extensive supply network or a single connection to one building. Hot water, drinking water, cooling and waste water are transported as reliably as many other liquid media in industrial applications. And the service we provide also means comprehensive support at every phase of the project.



## Fields of use

It is a mark of a good pipe system that it offers professional solutions to a large number of possible uses with just a few components. The capabilities of the flexible, pre-insulated pipes from Uponor suit them to highly varied applications.

### Uponor Ecoflex Thermo

Single and Twin pipes for a heating and cooling water supply. Ecoflex Thermo is a versatile solution for especially retrofit installations and house connections at demanding installation conditions.

### Uponor Ecoflex Thermo PRO

Single and Twin pipes for heating water supply. Ecoflex Thermo PRO is a energy efficient solution for heating networks.

### Uponor Ecoflex Varia

Single and Twin pipes for heating and cooling water supply. Uponor Varia products, meaning it has a smaller jacket as we offer in Thermo.

### Uponor Ecoflex Quattro

One pipe solution with two service pipes which are intended for warm tap water with circulation and two others for heating use.

### Uponor Ecoflex Aqua

Single or Twin pipes for warm tap water. The Aqua Twin version includes an integrated circulation line.

### Uponor Ecoflex Supra

The HDPE service pipe used in Supra is approved for transporting potable water. In addition to cold tap water applications, the preferred fields of use for Supra pipes are cooling water networks, for example in hotel complexes or industrial facilities.

### Uponor Ecoflex Supra PLUS and Supra PLUS 16 bar

Uponor Ecoflex Supra PLUS is a insulated water pipe containing a self-regulating heating cable that protects it from freezing. It is suitable for use as a drinking water pipe or pressure sewage system for resort

villages, holiday or family homes, farms, ski centres and other locations susceptible to freezing. The pipes enable a pipeline length of up to 150 m with a single power feed. If required, the Supra PLUS pipes can be laid directly on grade the snow. The connection between the Uponor Ecoflex Supra PLUS control unit, sensor and self-regulation heating cable is easy for qualified electricians. The sensor is installed into the small tube and controls the temperature near the medium pipe.

### Uponor Ecoflex Supra Standard

Uponor Ecoflex Supra Standard is a versatile insulated water pipe. A constant resistance heating cable controlled by the regulator keeps the water pipe unfrozen. Heating resistance cable enables a pipeline length of up to 700 m with a single power feed. Supra Standard is particularly suitable for the construction of pipe networks for resort villages and other larger areas.

### Uponor Ecoflex Supra Mantle

Uponor Ecoflex Supra Mantle protects the parts of a water pipe most susceptible to freezing, generally near the building foundation or inside a ventilated floor system. It can be used for new buildings as well as for renovations. There are two options to install the Ecoflex Supra Mantle: either to install it first and then push the medium pipe through the casing; or in case of existing service pipe, just simply to push the Ecoflex Supra Mantle over the service pipe. The cable brings the required heat into the jacket and the insulation layer helps retain the heat in the casing pipe.



## Quality, signed and sealed

Uncompromising quality is our number-one policy. Fully comprehensive quality control in production is just one aspect of our quality management system. And we regularly make sure that independent inspection organisations certify that our products meet the strictest standards.

### Kiwa KOMO approval and certification

The interplay between components (Uponor Thermo Single, Thermo Twin, rubber end caps, WIPEX fitting range and insulation kits) is examined in the twice-yearly system approval according to the current BRL 5609 guideline. The approval certifies a system service life of at least 30 years, as well as absence of leaks at a water pressure of 0.3 bar and an ambient temperature of 30 °C. In addition, the heat losses, static

strength and creep behaviour of the pipes are checked according to consistent specifications.

### In accordance with EN15632

Uponor flexible pre-insulated pipe systems are manufactured according to European Standard "EN15632 - Part 1, 2 and 3 - District heating pipes – pre-insulated flexible pipe systems" Selected Uponor Ecoflex flexible pipe systems and components are certified by KIWA.

### DIN Certco certification

The annual certification according to VDI 2055 verifies the Ecoflex Thermo heat loss values. The heat loss graphs for the flexible, pre-insulated pipes are prepared on this basis. The certification is based on defined layout conditions, and that means that the values are a good reflection of real life.

### Static strength certification

Selected Uponor Ecoflex flexible pipe systems and components are certified according to ATV DVWK-A127. When installed in accordance with ATV DVWK-A127, these pipes and components are suitable for loading by heavy traffic (SLW 60 = 60 t). The ring stiffness of the jacket pipe has been tested according to EN ISO 9969 to be able to withstand 4 kN/m<sup>2</sup> (class SN4).

### Insulation performance of cross linked PE-foam

The water absorption of cross linked PE-foam is less than 1% by volume when tested according to EN 15632-3. Low water absorption means the insulating properties remain almost stable.

kiwa





## Flexibility - from the beginning through to the house lead-in

No welding, no special tools. The flexibility and the low weight of our Ecoflex pipes mean that they are easy to handle and that building work proceeds fast. They are also supported by a comprehensive range of accessories. From a variety of wall lead-throughs, insulation kits and the proven range of fittings.

### The most important advantages for laying and connecting

- Problem-free laying around corners and obstacles
- Up to 240 meters of joint-free installation in one piece
- Self-adjusting tube structure make it unnecessary to fit expansion compensators.
- Fast building progress / short assembly times
- Easy, reliable jointing method, including subsequent insulation of connections and branches



- Cutting service: shorter lengths, individually trimmed for the building site
- Both standard and partial lengths are delivered in shortest time.
- Comprehensive support from experienced engineers for planning and layout
- Project support and product training on-site



Easy handling with both Ecoflex Thermo and Thermo PRO thanks to extraordinary flexibility in their classes.

## Key product information at a glance

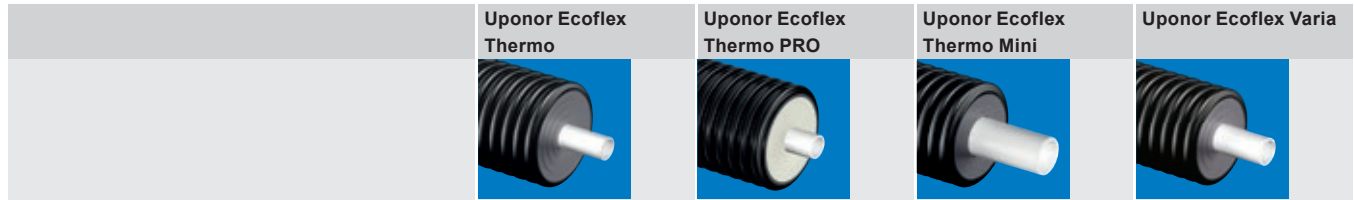

### Main Application

Tap water, warm				
Heating water	•	•	•	•
Cooling water	•	•	•	•

### Variations

Optional heating cable (only for single pipes)	•			
--	---	--	--	--

### Material

Medium pipe	PE-Xa with EVOH	PE-Xa with EVOH	PE-Xa with EVOH	PE-Xa with EVOH
Insulating material	cross-linked PE	PUR + cross-linked PE	cross-linked PE	cross-linked PE
Jacket pipes	PE-HD	PE-HD	PE-HD	PE-HD

<sup>1)</sup>for other applications and fluids (e. g. chemicals, foodstuff or waste water) call for confirmation

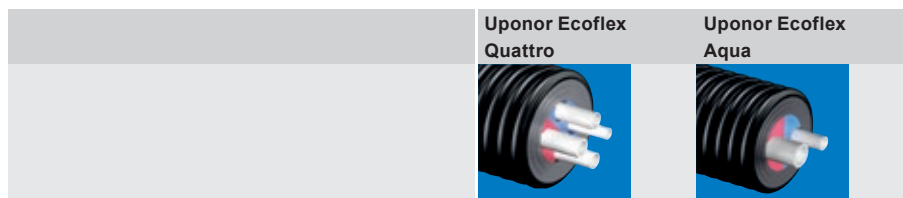

### Main Application

Tap water, warm	•	•
Heating water	•	
Cooling water		

### Variations

Optional heating cable (only for single pipes)		•
--	--	---

### Material

Medium pipe	PE-Xa and PE-Xa with EVOH	PE-Xa
Insulating material	cross-linked PE	cross-linked PE
Jacket pipes	PE-HD	PE-HD

<sup>1)</sup>for other applications and fluids (e. g. chemicals, foodstuff or waste water) call for confirmation

## Key product information at a glance



	Uponor Ecoflex Supra	Uponor Ecoflex Supra PLUS	Uponor Ecoflex Supra PLUS 16 bar	Uponor Ecoflex Supra Standard	Uponor Ecoflex Supra Mantle
<b>Main Application</b>					
Cooling	●				
Transport of cold water	●	●	●	●	
Freeze-protection		●	●	●	●
<b>Other Applications</b>					
Foodstuffs	on request	on request	on request	on request	
Chemicals	on request	on request	on request	on request	
Pressurized waste water	●	●	●	●	
<b>Materials</b>					
Medium pipe	PE 100 black/ blue Layer	PE 80/ PE 100 black	PE 100 black/ blue Layer	PE 80/ PE 100 black	
Insulation	cross-linked PE	cross-linked PE	cross-linked PE	cross-linked PE	cross-linked PE
Jacket pipe	HDPE	HDPE	HDPE	HDPE	HDPE
Cable		self-regulating cable	self-regulating cable	constant resistant cable	self-regulating cable with plug



# Product profiles

## Uponor Ecoflex Thermo

### Practical, ideal and versatile for heating water supply

The ideal solution for distributing heating water in local heat supply networks, or for connecting building complexes and single houses. The Thermo Twin version also combines flow and return lines in a flexible pipe system. The classification of the Thermo pipe system is described in EN 15632-3 as a non bonded system with a plastic medium pipe.

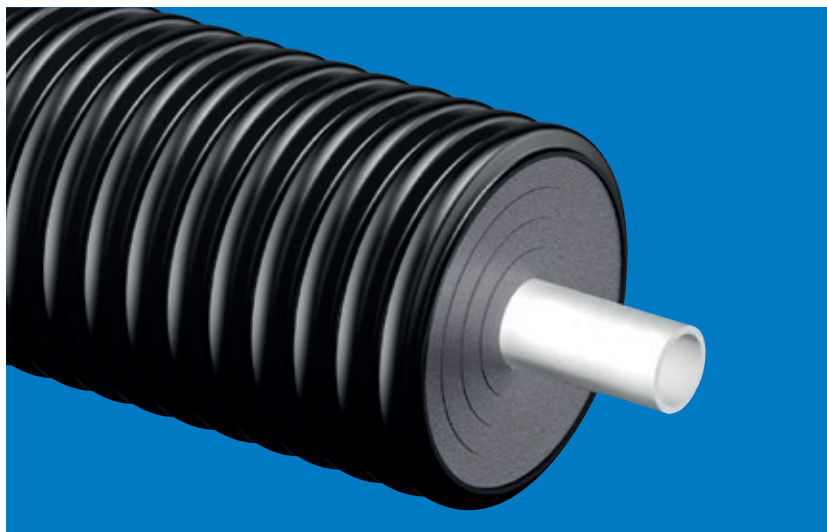

## Uponor Ecoflex Thermo PRO

### Ideal for energy efficient heating water supply systems

The ideal solution for energy efficient heating water distribution in local heating networks. The Thermo PRO Twin version also combines flow and return lines in a flexible pipe system. The classification of Thermo PRO system is described in EN 15632-2 as a bonded composite system with plastic medium pipe.

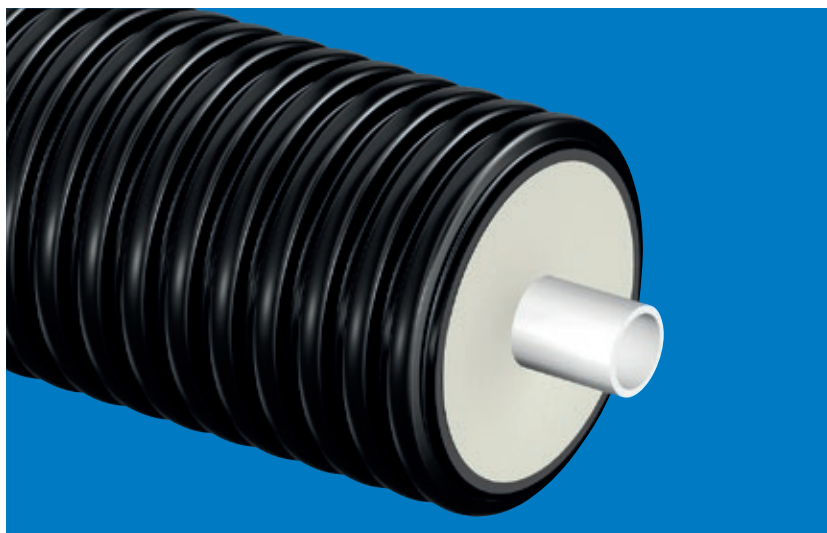

## Uponor Ecoflex Varia

### Flexible specialist for heating water

Uponor Ecoflex Varia is a flexible, pre-insulated, self-compensating plastic pipe system for transporting heating water in buried installations. It is offered in two versions; Single and Twin. Varia pipes have smaller jacket pipe than our Thermo pipes, meaning it is more flexible.

The Ecoflex Varia Twin version is suitable for transporting heating water flow and return line plus integrated coloured "Dogbone", to avoid confusion.

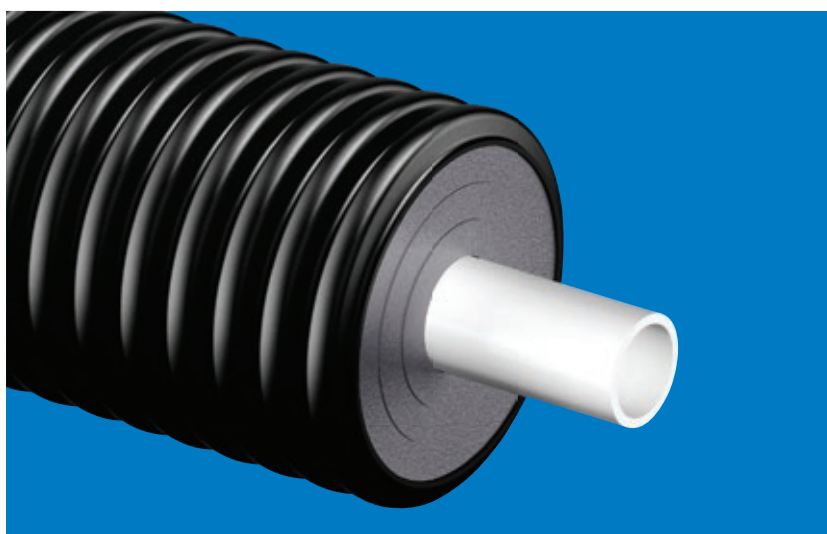

## Uponor Ecoflex Quattro

### The right way to make single building connections

"One for all!" Heat water supply and return, along with service water, including circulation, in just one pipe line: single buildings or building complexes could not be connected in a more convenient, more economical or more reliable way.

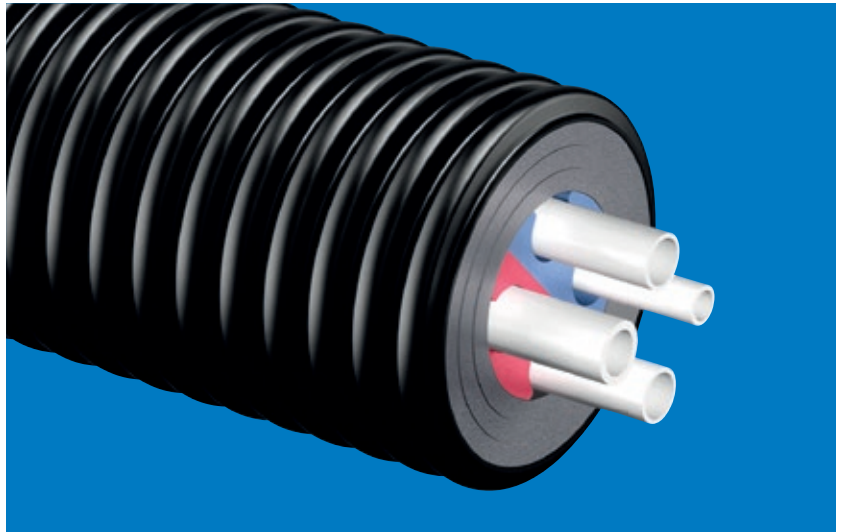

## Uponor Ecoflex Aqua

### The flexible specialist for hot tap water

Unbeatable for fast, reliable and therefore very economical installation in the hot water service system. The twin version offers a solution with an integrated circulation pipe. The classification of the PE-Xa medium pipes for the Aqua pipe system are described in EN ISO 15875.

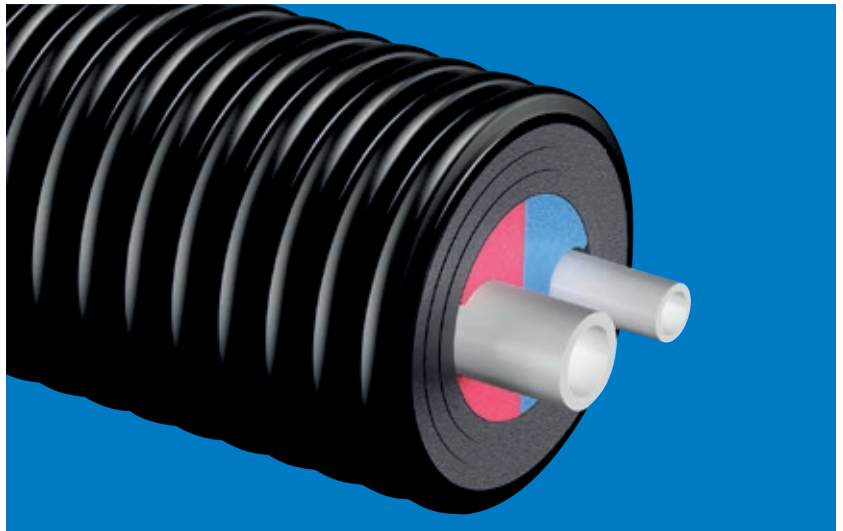

## Uponor Ecoflex Supra

### Reliability for cold water supply and cooling networks

Uponor Ecoflex Supra pipes are the preferred solution for cooling water networks in holiday resorts, hotel complexes or industrial facilities. Supra is optimized for applications at operating temperature from -10 °C to +20 °C. Easy and fast installation and low need for maintenance ensure carefree and cost-efficient life cycle of the system. Cooling capacity is optimized by efficient thermal insulation and a securely tight construction of the pipes and joints.

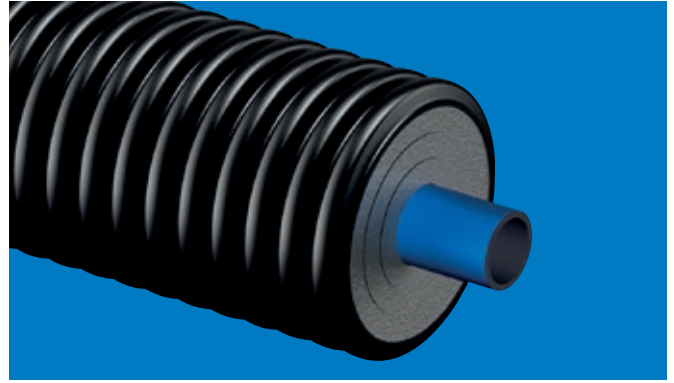

## Uponor Ecoflex Supra PLUS

### Carefree living even in cold temperatures

Uponor Ecoflex Supra PLUS is an insulated polyethylene pipe for locations susceptible to freezing. It is a good choice for one-family homes, farms and cottages situated in sparsely populated areas. Supra PLUS is supplied on a maximum 150 m pipe coil completely ready for installation. The self-regulating heating cable makes it possible to cut the Supra PLUS pipe at the required length. The service pipe sizes are Ø 25–110 mm. The service pipe can be connected with Uponor Wipex coupling, electrofusion fittings or plastic screw fittings which are approved for PE 100, SDR 11 pipes from sources in the market worldwide.

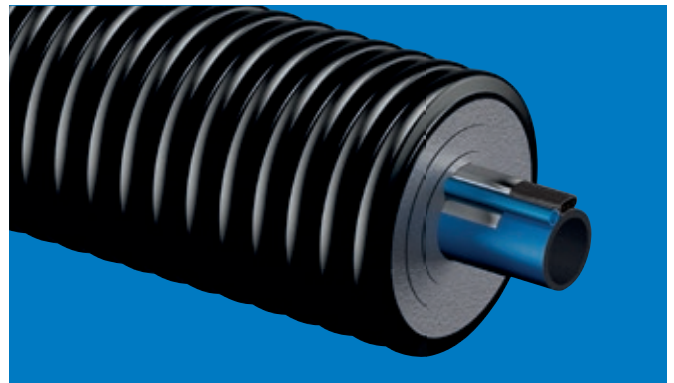

## Uponor Ecoflex Supra Standard

### Non-freeze water pipes for longer pipelines

Uponor Ecoflex Supra Standard is a versatile insulated water pipe. The standard resistance cable controlled by the regulator keeps the water pipe unfrozen. The standard resistance cable enables a pipeline length of up to 700 m with a single power feed. Supra Standard is particularly suitable for the construction of pipe networks for resort villages and other larger areas.

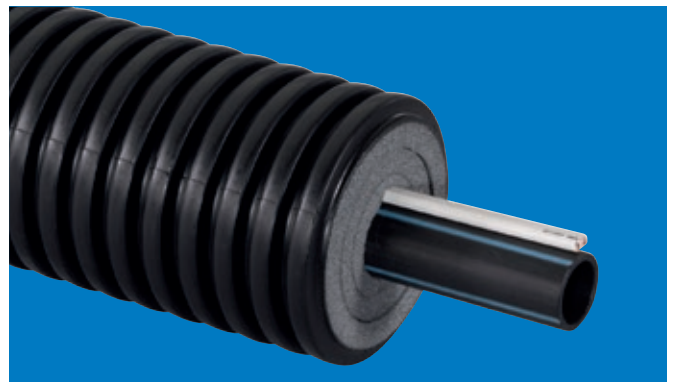

## Uponor Ecoflex Supra Mantle

Uponor Ecoflex Supra Mantle protects the parts of a water pipe most susceptible to freezing, generally near the building foundation or inside a ventilated floor system. It can be used for new buildings as well as for renovations, and can be used both with new medium pipe installations as well as for protection of existing medium pipes. The cable brings the required heat into the jacket and the insulation layer helps retain the heat in the casing pipe.

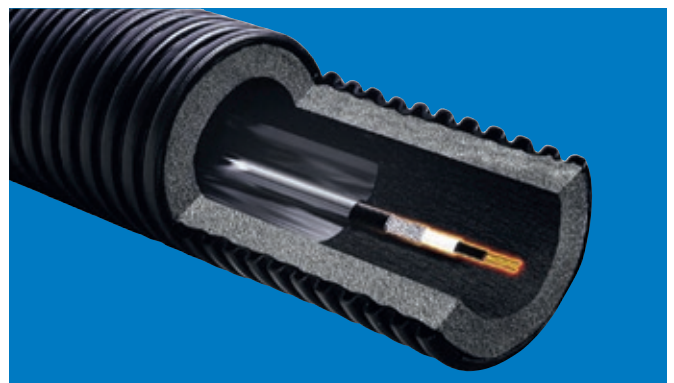



# Uponor Ecoflex Thermo and Varia: flexibility and ease of installation

The combination of stable yet flexible jacket pipes, ageing-resistant cross linked polyethylene insulating layers and robust, long-life PEX media pipes result a flexible and reliable pipe construction with excellent installation characteristics.

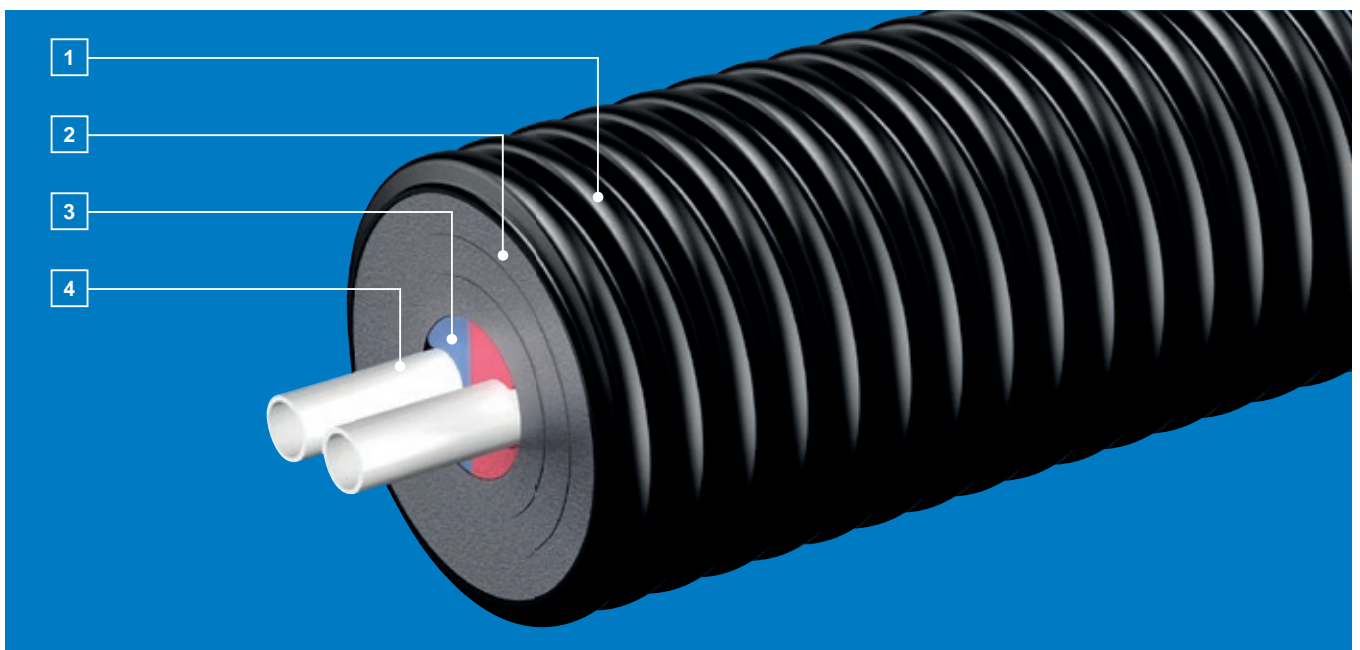

- 1** The PE-HD jacket pipe: impact-resistant, long-life yet flexible due to the Uponor pipe geometry
- 2** The insulation made from cross linked polyethylene foam: ideal insulating properties, ageing-resistant, resistance to moisture and very high flexibility
- 3** The coloured centring profile effectively avoids confusion between the flow and return pipes
- 4** The PE-Xa medium pipe: temperature-resistant, and resistant to incrustation and stress cracking

## The benefits

- Easy handling and fast building progress through exceptional flexibility
- Age-resistant, permanently elastic insulation of closed-cell cross linked polyethylene foam, water absorption < 1% by volume
- Heat losses externally monitored by DIN Certco
- Medium pipe resistant to corrosion and incrustation
- The medium pipe made of crosslinked polyethylene (PE-Xa) offers exceptional resistance to stress cracking, aggressive media, frost and micro-organisms
- Optimum ring stiffness, resistant to impact and pressure at the same time as offering high flexibility when laying and low specific weight of all the materials

## Uponor Ecoflex Thermo Single



80 °C \*  
max.95 °C



6 or 10 bar



25–125 mm

### Primary application

- Heating water

### Secondary applications

- Cooling water
- Chemicals (call for confirmation)

### Medium pipe

- PE-Xa with EVOH, SDR 11 (6 bar)  
or
- PE-Xa with EVOH, SDR 7.4 (10 bar)

### Option

- Heating cable

### Insulating material

- Cross linked PE-foam

### Jacket pipe material

- PE-HD

### NOTE!

The proven standard solution for heating water distribution in local heating networks and for single building connections.

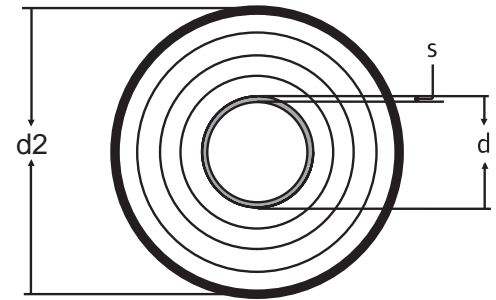

\* please note the explanations on page 129

## Uponor Ecoflex Thermo Single PN 6 pipe range

Item no.	Medium pipe d x s [mm]	DN [mm]	Jacket pipe d2 [mm]	Bending radius [m]	Weight [kg/m]	Max. length on delivery [m]	U-Value [W/K·m <sup>2</sup> ]
1018109	25 x 2.3	20	140	0.25	1.18	200	0.148
1018110	32 x 2.9	25	140	0.30	1.31	200	0.174
1018111	40 x 3.7	32	175	0.35	2.20	200	0.172
1018112	50 x 4.6	40	175	0.45	2.40	200	0.203
1018113	63 x 5.8	50	175	0.55	2.80	200	0.249
1018114	75 x 6.8	65	200	0.80	3.74	100	0.257
1018115	90 x 8.2	80	200	1.10	4.20	100	0.315
1018116	110 x 10.0	100	200	1.20	5.24	100	0.421
1083868	125 x 11.4	125	250	1.40	7.30	120	0.378

## Uponor Ecoflex Thermo Single PN 6 with cable pipe range

Item no.	Medium pipe d x s [mm]	DN [mm]	Jacket pipe d2 [mm]	Bending radius [m]	Weight [kg/m]	Max. length on delivery [m]
1018165	25 x 2.3	20	140	0.25	1.33	100
1018166	32 x 2.9	25	140	0.30	1.46	100
1018167	40 x 3.7	32	175	0.35	2.18	100
1018168	50 x 4.6	40	175	0.45	2.41	100
1018169	63 x 5.8	50	175	0.55	2.71	100
1018170	75 x 6.8	65	200	0.80	3.89	100
1018171	90 x 8.2	80	200	1.10	4.35	100
1018172	110 x 10.0	100	200	1.20	5.39	100

## Uponor Ecoflex Thermo Single PN 10 pipe range

Item no.	Medium pipe d x s [mm]	DN [mm]	Jacket pipe d2 [mm]	Bending radius [m]	Weight [kg/m]	Max. length on delivery [m]
1045877	40 x 5.5	32	175	0.45	2.40	200
1045878	50 x 6.9	40	175	0.55	2.70	200
1045879	63 x 8.6	50	175	0.65	3.20	200
1061041	75 x 10.3	65	200	0.90	4.30	100
1061042	90 x 12.3	80	200	1.20	5.30	100
1061043	110 x 15.1	100	200	1.30	6.50	100

## Uponor Ecoflex Thermo Mini pipe range

Item no.	Medium pipe d x s [mm]	DN [mm]	Jacket pipe d2 [mm]	Bending radius [m]	Weight [kg/m]	Max. length on delivery [m]
1018132	25 x 2.3	20	68	0.2	0.5	200
1018133	32 x 2.9	25	68	0.25	0.55	200

## Uponor Ecoflex Thermo Twin

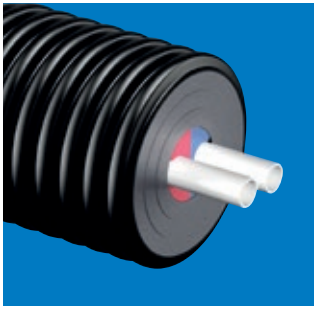

80 °C \*  
max.95 °C



6 or 10 bar



25–75 mm

### Primary application

- Heating water

### Secondary applications

- Cooling water
- Chemicals (call for confirmation)

### Medium pipe

- PE-Xa with EVOH, SDR 11 (6 bar) or
- PE-Xa with EVOH, SDR 7.4 (10 bar)

### Insulating material

- Cross linked PE-foam

### Jacket pipe material

- PE-HD

### NOTE!

Combined flow and return lines in one pipe system, including two-colour centre in profile to avoid confusion during assembly.

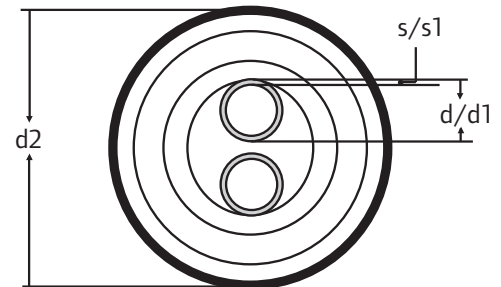

\* please note the explanations on page 129

## Uponor Ecoflex Thermo Twin PN 6 pipe range

Item no.	Medium pipe d x s [mm]	Medium pipe d1 x s1 [mm]	DN [mm]	Jacket pipe d2 [mm]	Bending radius [m]	Weight [kg/m]	Max. length on delivery [m]	U-Value [W/K·m <sup>2</sup> ]
1018134	25 x 2.3	25 x 2.3	20 + 20	175	0.50	2.20	200	0.201
1018135	32 x 2.9	32 x 2.9	25 + 25	175	0.60	2.40	200	0.241
1018136	40 x 3.7	40 x 3.7	32 + 32	175	0.80	2.60	200	0.293
1018137	50 x 4.6	50 x 4.6	40 + 40	200	1.00	3.50	100	0.314
1018138	63 x 5.8	63 x 5.8	50 + 50	200	1.20	4.55	100	0.420
1088276	75 x 6.8	75 x 6.8	65 + 65	250	1.40	6.50	100	0.369

## Uponor Ecoflex Thermo Twin PN 10 pipe range

Item no.	Medium pipe d x s [mm]	Medium pipe d1 x s1 [mm]	DN [mm]	Jacket pipe d2 [mm]	Bending radius [m]	Weight [kg/m]	Max. length on delivery [m]
1045880	25 x 3.5	25 x 3.5	20 + 20	175	0.65	2.50	200
1045881	32 x 4.4	32 x 4.4	25 + 25	175	0.70	2.70	200
1045882	40 x 5.5	40 x 5.5	32 + 32	175	0.90	2.90	200
1045883	50 x 6.9	50 x 6.9	40 + 40	200	1.00	3.80	200



## Uponor Ecoflex Varia Single



80 °C \*  
max. 95 °C



6 bar



25–125 mm

### Primary application

- Heating water

### Secondary applications

- Foodstuffs (call for confirmation)
- Chemicals (call for confirmation)

### Medium pipe

- PE-Xa with EVOH, SDR 11 (6 bar)

### Insulating material

- Cross linked PE-foam

### Jacket pipe material

- PE-HD

### NOTE!

The alternative solution for heating water distribution in local heating networks and for single building connections.

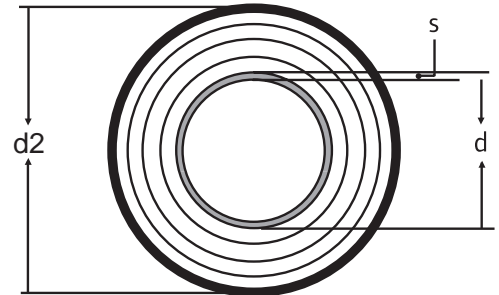

\* please note the explanations on page 129

## Uponor Ecoflex Varia Single PN 6 pipe range

Item no.	Medium pipe d x s [mm]	DN [mm]	Jacket pipe d2 [mm]	Bending radius [m]	Weight [kg/m]	Max. length on delivery [m]	U-Value [W/K·m <sup>2</sup> ]
1018230	25 x 2.3	20	90	0.25	1.02	200	0.188
1018231	32 x 2.9	25	90	0.30	1.12	200	0.231
1018232	40 x 3.7	32	140	0.35	1.47	200	0.210
1018233	50 x 4.6	40	140	0.40	1.67	200	0.270
1018234	63 x 5.8	50	140	0.50	1.97	200	0.350
1018235	75 x 6.8	65	175	0.60	2.72	200	0.330
1018236	90 x 8.2	80	175	0.70	3.14	100	0.410
1018237	110 x 10.0	100	175	0.90	4.14	100	0.600
1062886	125 x 11.4	125	200	1.30	5.80	80	0.534

## Uponor Ecoflex Varia Twin



80 °C \*  
max. 95 °C



6 bar



25–50 mm

### Primary application

- Heating water

### Secondary applications

- Foodstuffs (call for confirmation)
- Chemicals (call for confirmation)

### Medium pipe

- PE-Xa with EVOH, SDR 11  
(6 bar) or

### Insulating material

- Cross linked PE-foam

### Jacket pipe material

- PE-HD

### NOTE!

Combined flow and return lines in one pipe system, including two-colour centering profile helps to differentiate supply and return lines.

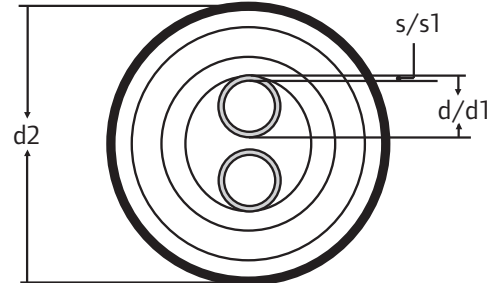

\* please note the explanations on page 129

## Uponor Ecoflex Varia Twin PN 6 pipe range

Item no.	Medium pipe d x s [mm]	Medium pipe d1 x s1 [mm]	DN [mm]	Jacket pipe d2 [mm]	Bending radius [m]	Weight [kg/m]	Max. length on delivery [m]	U-Value [W/K·m <sup>2</sup> ]
1018238	25 x 3.5	25 x 3.5	20 + 20	140	0.40	1.36	200	0.246
1018238	32 x 4.4	32 x 4.4	25 + 25	140	0.50	1.43	200	0.300
1018240	40 x 5.5	40 x 5.5	32 + 32	140	0.70	2.08	200	0.456
1018241	50 x 6.9	50 x 6.9	40 + 40	175	0.9	2.84	200	0.380

# Uponor Ecoflex Thermo PRO: energy efficiency

The unique construction of Ecoflex Thermo PRO combines energy efficiency and good level of flexibility. The known features of Ecoflex product range such as corrugated jacket and layer of cross-linked PE foam together with PUR insulation material provide optimal solution for energy efficient distribution networks.

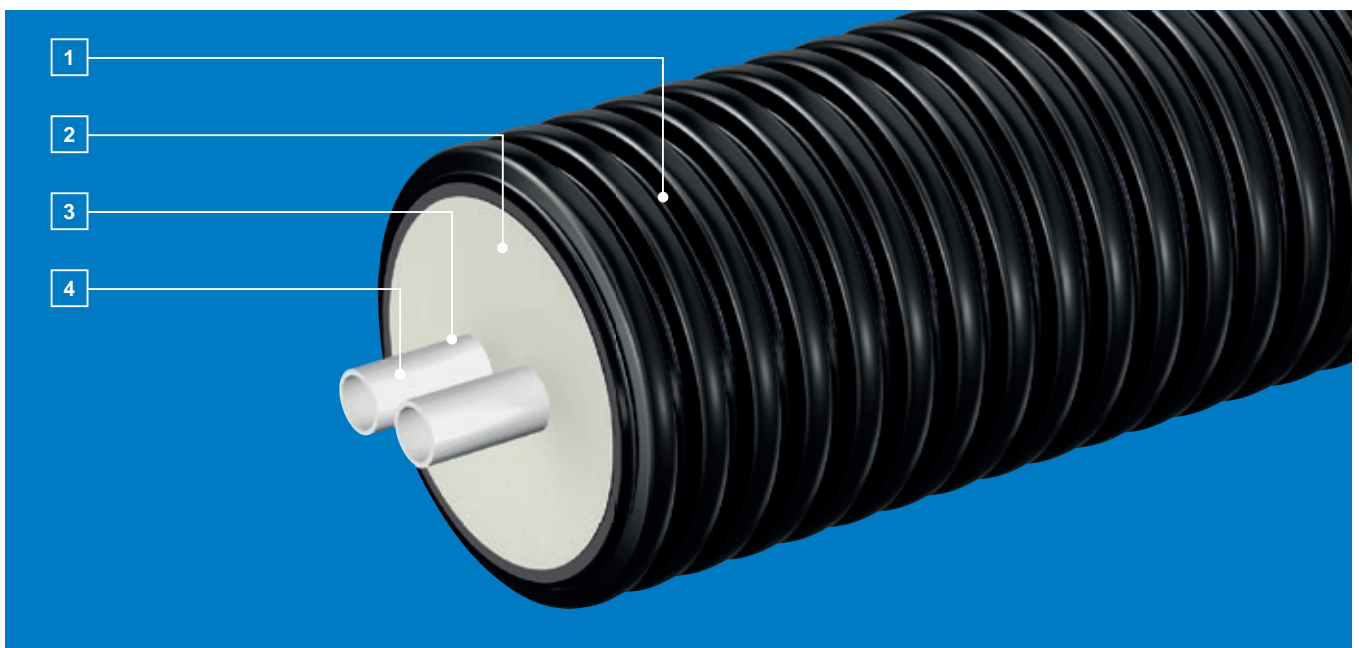

- 1** The PE-HD jacket pipe: impact-resistant, long-life yet flexible due to the Uponor pipe geometry
- 2** An innovative combination of PUR foam insulation and cross linked polyethylene foam creates a best in class flexibility
- 3** Marking on one medium pipe differentiates supply and return at twin pipe configurations
- 4** The PE-Xa medium pipe: temperature resistant and resistant to incrustation and stress cracking

## The benefits

- Excellent energy efficiency due to high insulation performance
- Unique pipe construction provides best in class flexibility and long term performance of a heating system.
- Medium pipe resistant to corrosion and incrustation
- The medium pipe made of crosslinked polyethylene (PE-Xa) offers exceptional resistance to stress cracking, aggressive media, frost and micro-organisms
- Optimum ring stiffness, resistant to impact and pressure at the same time as offering high flexibility when laying and low specific weight of all the materials

## Uponor Ecoflex Thermo PRO Single

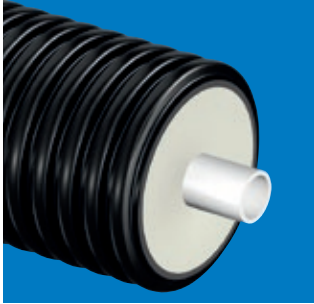

80 °C \*  
max.95 °C



6 bar



40–110 mm

### Primary application

- Heating water

### Secondary applications

- Waste water
- Chemicals (call for confirmation)
- Cooling water

### Medium pipe

- PE-Xa with EVOH, SDR 11 (6 bar)

### Insulating material

- PUR foam and cross linked PE foam

### Jacket pipe material

- PE-HD (PE 80)

### NOTE!

The proven standard solution for heating water distribution in local heating networks.

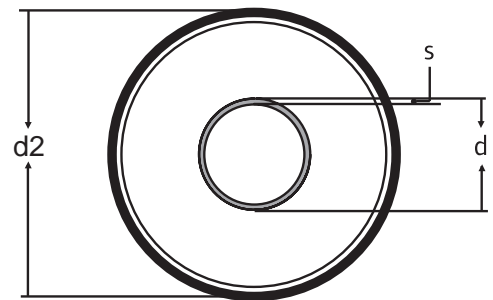

\* please note the explanations on page 129

## Uponor Ecoflex Thermo PRO Single PN 6 pipe range

Item no.	Medium pipe d x s [mm]	DN [mm]	Jacket pipe d2 [mm]	Bending radius [m]	Weight [kg/m]	Max. length on delivery [m]	U-Value [W/K·m <sup>2</sup> ]
1087378	40 x 3.7	32	145	0.50	1.99	240	0.112
1087379	40 x 3.7	32	175	0.70	3.07	150	0.097
1087383	50 x 4.6	40	145	0.60	2.27	240	0.137
1087384	50 x 4.6	40	175	0.70	2.96	150	0.116
1087385	63 x 5.8	50	175	0.70	3.26	150	0.144
1087386	63 x 5.8	50	200	0.80	3.84	100	0.128
1087387	75 x 6.8	65	175	0.80	3.60	150	0.176
1087388	75 x 6.8	65	200	0.90	4.18	100	0.152
1087389	90 x 8.2	80	200	1.10	4.70	100	0.195
1087390	110 x 10.0	100	200	1.20	5.51	100	0.265

## Uponor Ecoflex Thermo PRO Twin



80 °C \*  
max.95 °C



6 bar



25–63 mm

### Primary application

- Heating water

### Secondary applications

- Waste water
- Chemicals (call for confirmation)
- Cooling water

### Medium pipe

- PE-Xa with EVOH, SDR 11  
(6 bar)

### Insulating material

- PUR Foam and cross linked PE foam

### Jacket pipe material

- PE-HD

### NOTE!

Combined flow and return lines in one pipe system.

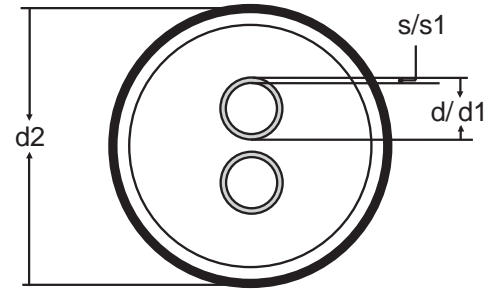

\* please note the explanations on page 129

## Uponor Ecoflex Thermo PRO Twin PN 6 pipe range

Item no.	Medium pipe d x s [mm]	Medium pipe d1 x s1 [mm]	DN [mm]	Jacket pipe d2 [mm]	Bending radius [m]	Weight [kg/m]	Max. length on delivery [m]	U-Value [W/K·m <sup>2</sup> ]
1087392	25 x 2.3	25 x 2.3	20+20	145	0.60	1.97	240	0.135
1087393	25 x 2.3	25 x 2.3	20+20	175	0.70	2.71	150	0.115
1087394	32 x 2.9	32 x 2.9	25+25	145	0.60	2.15	240	0.171
1087395	32 x 2.9	32 x 2.9	25+25	175	0.80	2.87	150	0.138
1087396	40 x 3.7	40 x 3.7	32+32	175	0.80	3.13	150	0.173
1087397	40 x 3.7	40 x 3.7	32+32	200	1.00	3.70	100	0.149
1087398	50 x 4.6	50 x 4.6	40+40	200	1.10	4.08	100	0.193
1087399	63 x 5.8	63 x 5.8	50+50	200	1.20	4.69	100	0.263



# Uponor Ecoflex Aqua: the flexible specialist for warm tap water

Unbeatable for fast, reliable and therefore very economical installation in the hot water service system. The twin version offers a solution with an integrated circulation pipe. The classification of the PE-Xa medium pipes for the Aqua pipe system are described in EN ISO 15875.

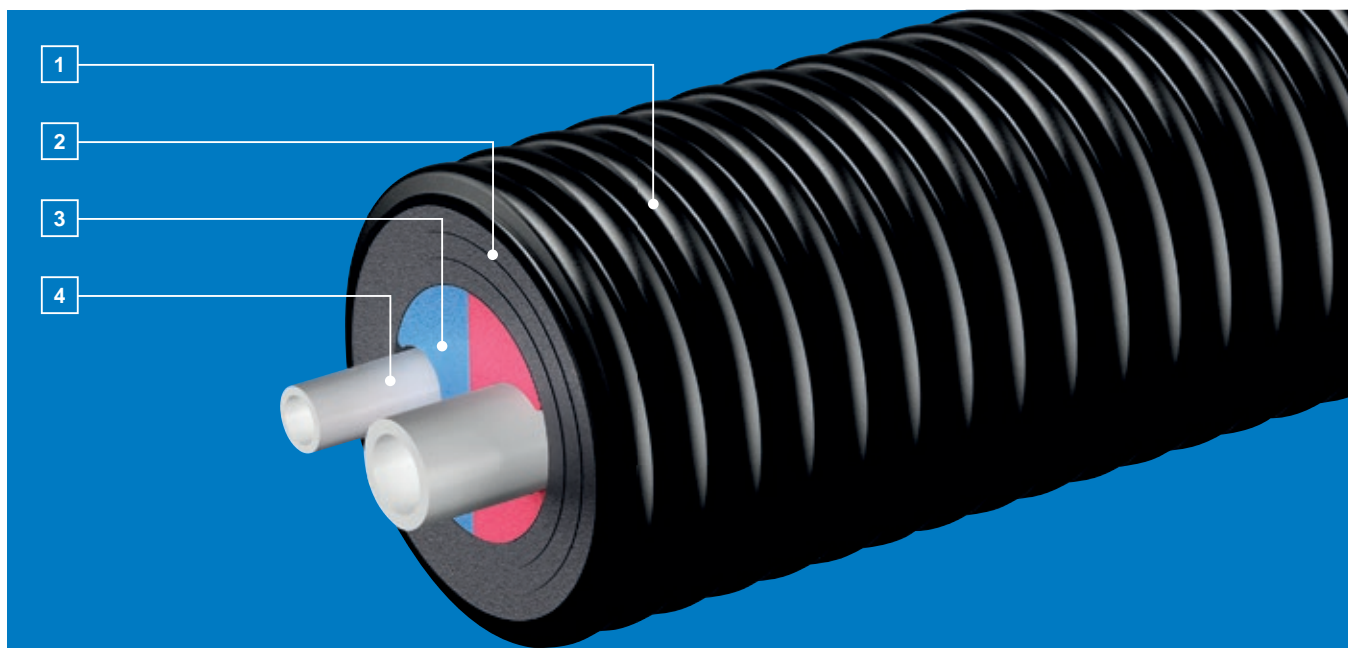

- 1** The PE-HD jacket pipe: impact-resistant, long-life yet flexible due to the Uponor pipe geometry
- 2** The insulation made from cross linked polyethylene foam: ideal insulating properties, ageing-resistant, resistance to moisture and very high flexibility
- 3** The coloured centring profile effectively avoids confusion between the flow and return pipes
- 4** Hygienic PE-Xa medium pipe: temperature-resistant, and resistant to incrustation and stress cracking

## The benefits

- Easy handling and fast building progress through exceptional flexibility
- Good level of heat loss performance by high amount of insulation and thermal properties
- Age-resistant, permanently elastic insulation of closed-cell cross linked polyethylene foam, water absorption < 1% by volume
- Optimum ring stiffness, resistant to impact and pressure at the same time as offering high flexibility when laying and low specific weight of all the materials

## Uponor Ecoflex Aqua Single



70 °C \*  
max. 95 °C



10 bar



25–110 mm

### Primary application

- Warm tap water

### Secondary applications

- Foodstuffs (call for confirmation)
- Chemicals (call for confirmation)

### Medium pipe

- PE-Xa, SDR 7.4

### Option

- Heating cable

### Insulating material

- Cross-linked PE foam

### Jacket pipe material

- PE-HD

### NOTE!

The reliable, economical pipe for warm water installations.

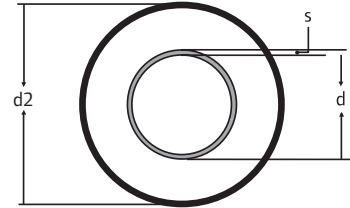

\* please note the explanations on page 129

## Uponor Ecoflex Aqua Single offering

Item no.	Medium pipe d x s [mm]	DN [mm]	Jacket pipe d2 [mm]	Bending radius [m]	Weight [kg/m]	Max. length on delivery [m]	U-value [W/K·m <sup>2</sup> ]
1018117	25 x 3.5	20	140	0.35	1.24	200	0.146
1034180	28 x 4.0	20	140	0.35	1.30	200	0.156
1018118	32 x 4.4	25	140	0.40	1.42	200	0.172
1018119	40 x 5.5	32	175	0.45	2.40	200	0.169
1018120	50 x 6.9	40	175	0.55	2.70	200	0.201
1018121	63 x 8.6	50	175	0.65	3.20	200	0.246
1018122	75 x 10.3	65	200	0.90	4.34	100	0.253
1018123	90 x 12.3	80	200	1.20	5.30	100	0.312
1036036	110 x 15.1	100	200	1.30	6.50	100	0.410

## Uponor Ecoflex Aqua Single with heating cable offering

Item no.	Medium pipe d x s [mm]	DN [mm]	Jacket pipe d2 [mm]	Bending radius [m]	Weight [kg/m]	Max. length on delivery [m]	U-value [W/K·m <sup>2</sup> ]
1018173	25 x 3.5	20	140	0.35	1.39	100	0.146
1018174	32 x 4.4	25	140	0.40	1.61	100	0.172
1018175	40 x 5.5	32	175	0.45	2.35	100	0.169
1018176	50 x 6.9	40	175	0.55	2.73	100	0.201
1018177	63 x 8.6	50	175	0.65	3.19	100	0.246

## Uponor Ecoflex Aqua Twin

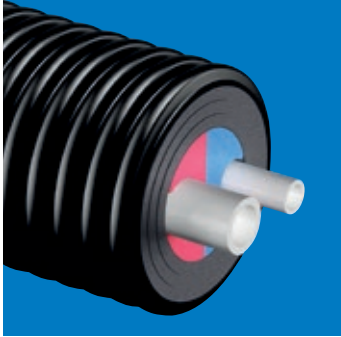

70 °C \*  
max.95 °C



10 bar



18–50 mm

### Primary application

- Warm tap water, with circulation

### Secondary applications

- Foodstuffs (call for confirmation)
- Chemicals (call for confirmation)

### Medium pipe

- PE-Xa, SDR 7.4

### Insulating material

- Cross-linked PE foam

### Jacket pipe material

- PE-HD

### NOTE!

Warm water and circulation combined in on pipe. The two-coloured centring profile simplifies correct connection of the medium pipes.

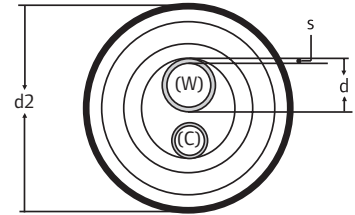

\* please note the explanations on page 129

## Uponor Ecoflex Aqua Twin offering

Item no.	Medium pipe d x s [mm]	Medium pipe d1 x s1 [mm]	DN [mm]	Jacket pipe d2 [mm]	Bending radius [m]	Weight [kg/m]	Max. length on delivery [m]	U-value [W/K·m <sup>2</sup> ]
1084885	25 x 3.5	20 x 2.8	20 + 15	140	0.65	1.75	200	0.196
1018139	25 x 3.5	25 x 3.5	20 + 20	175	0.65	2.05	200	
1034185	28 x 4.0	18 x 2.5	20 + 12	140	0.65	1.40	200	
1044011	28 x 4.0	22 x 3.0	20 + 15	140	0.65	1.50	200	
1034186	32 x 4.4	18 x 2.5	25 + 12	175	0.70	2.30	200	
1084886	32 x 4.4	20 x 2.8	25 + 15	175	0.70	2.4	200	0.186
1044012	32 x 4.4	22 x 3.0	25 + 20	175	0.70	2.40	200	
1018140	32 x 4.4	25 x 3.5	25 + 20	175	0.70	2.20	200	
1044014	32 x 4.4	28 x 4.0	25 + 20	175	0.70	2.50	200	
1018141	40 x 5.5	25 x 3.5	32 + 20	175	0.90	2.45	200	0.222
1034187	40 x 5.5	28 x 4.0	32 + 20	175	0.90	2.70	200	
1044015	40 x 5.5	32 x 4.4	32 + 25	175	0.90	2.80	200	
1018142	50 x 6.9	25 x 3.5	40 + 20	175	1.00	2.73	200	
1034188	50 x 6.9	32 x 4.4	40 + 25	175	1.00	3.10	200	0.274
1044016	50 x 6.9	40 x 5.5	40 + 32	200	1.00	3.50	100	
1044013	50 x 6.9	50 x 6.9	40 + 40	200	1.00	3.60	100	

# Uponor Ecoflex Quattro: smart way to make single building connections

"One for all!" Heating water supply and return, along with warm tap water with circulation, in just one pipe line: single buildings or building complexes could not be connected on a more convenient, more economical or more reliable way.

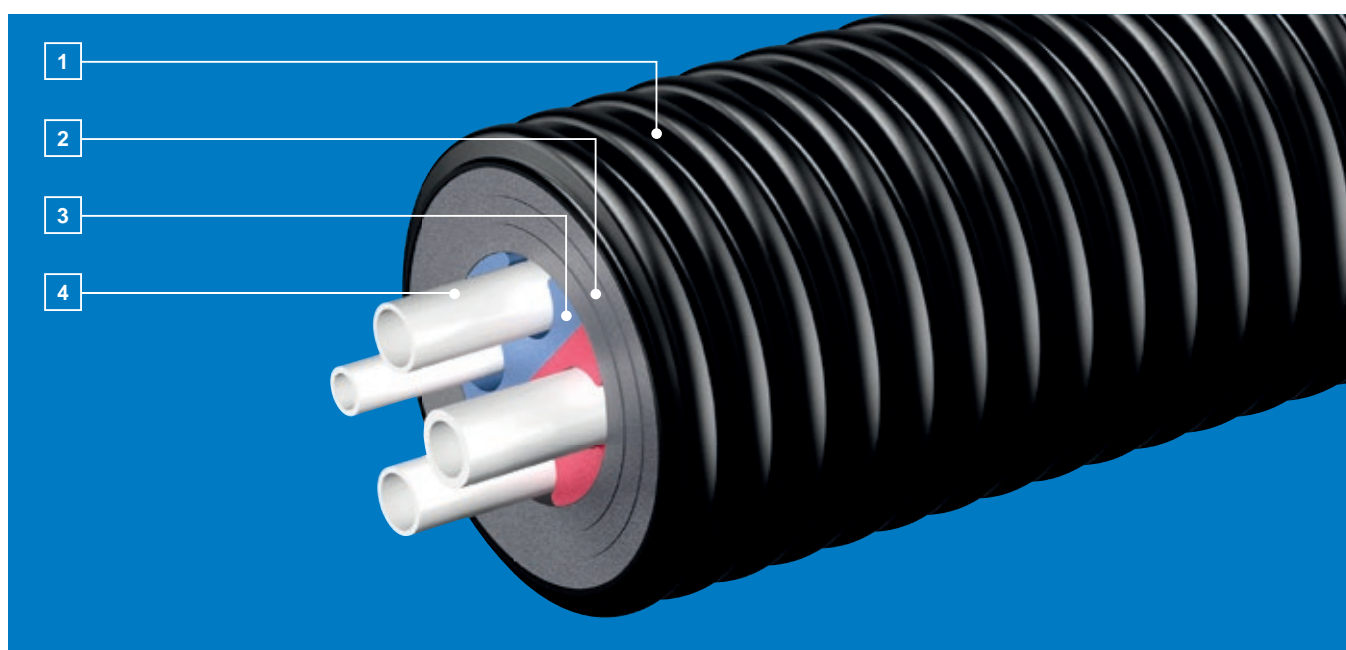

- 1** The PE-HD jacket pipe: impact-resistant, long-life yet flexible due to the Uponor pipe geometry
- 2** The insulation made from cross linked polyethylene foam: ideal insulating properties, ageing-resistant, resistance to moisture and very high flexibility
- 3** Two coloured centering profile effectively avoids confusion between the flow and return pipes
- 4** Four medium pipes two for heating and warm tap water supply together with circulation

## The benefits

- In all aspects most economical way to connect a building with heating and warm tap water supply
- Good level of heat loss performance by high amount of insulation and thermal properties
- Age-resistant, permanently elastic insulation of closed-cell cross linked polyethylene foam, water absorption < 1% by volume
- Optimum ring stiffness, resistant to impact and pressure at the same time as offering high flexibility when laying

## Uponor Ecoflex Quattro

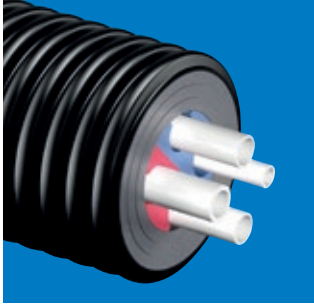

70/80 °C \*  
max.95 °C



6 bar +  
10 bar



18–50 mm

### Primary application

- Heating water
- Warm tap water with circulation

### Medium pipe

- PE-Xa, SDR 7,4 (10 bar) and
- PE-Xa with EVOH, SDR 11 (6 bar)

### Insulating material

- Cross-linked PE foam

### Jacket pipe material

- PE-HD (PE 80)

### NOTE!

The Uponor Ecoflex Quattro pipeline is also particularly practical and economical for connecting auxiliary buildings. The two-coloured centering profile simplifies correct connection of the medium pipes.

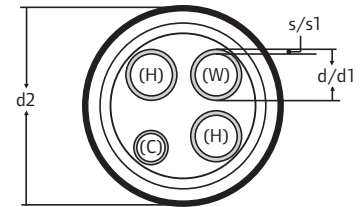

\* please note the explanations on page 129

## Uponor Ecoflex Quattro offering

Item no.	Medium pipe d x s [mm]	Medium pipe d1 x s1 [mm]	Jacket pipe d2 [mm]	Bending radius [m]	Weight [kg/m]	Max. length on delivery [m]	U-value [W/K·m <sup>2</sup> ]
1034173	2 x 25 x 2.3	28 x 4.0 + 18 x 2.5	175	0.8	2.4	200	
1084887	2 x 25 x 2.3	25 x 3.5 + 20 x 2.8	175	0.8	2.3	200	0,235
1018147	2 x 25 x 2.3	2 x 25 x 3.5	175	0.8	2.41	200	0,242
1084888	2 x 32 x 2.9	25 x 3.5 + 20 x 2.8	175	0.8	2.5	200	0,262
1018148	2 x 32 x 2.9	2 x 25 x 3.5	175	0.8	2.64	200	0,268
1034174	2 x 32 x 2.9	28 x 4.0 + 18 x 2.5	175	0.8	2.6	200	
1044017	2 x 32 x 2.9	2 x 28 x 4.0	175	0.8	2.7	200	
1034175	2 x 32 x 2.9	32 x 4.4 + 18 x 2.5	175	0.8	2.8	200	
1084889	2 x 32 x 2.9	32 x 4.4 - 20 x 2.8	175	0.8	2.9	200	0,276
1018149	2 x 32 x 2.9	32 x 4.4 + 25 x 3.5	175	0.8	2.78	200	0,282
1044018	2 x 32 x 2.9	2 x 32 x 4.4	175	0.8	2.9	200	
1044020	2 x 40 x 3.7	32 x 4.4 + 18 x 2.5	200	1	3.4	100	
1084891	2 x 40 x 3.8	32 x 4.4 + 20 x 2.8	200	1	3.5	100	0,274
1084890	2 x 40 x 3.7	40 x 5.5 + 25 x 3.5	200	1	3.6	100	0,293
1034176	2 x 40 x 3.7	40 x 5.5 + 28 x 4.0	200	1	3.7	100	
1044019	2 x 40 x 3.7	2 x 40 x 5.5	200	1	3.8	100	0,314



# Design

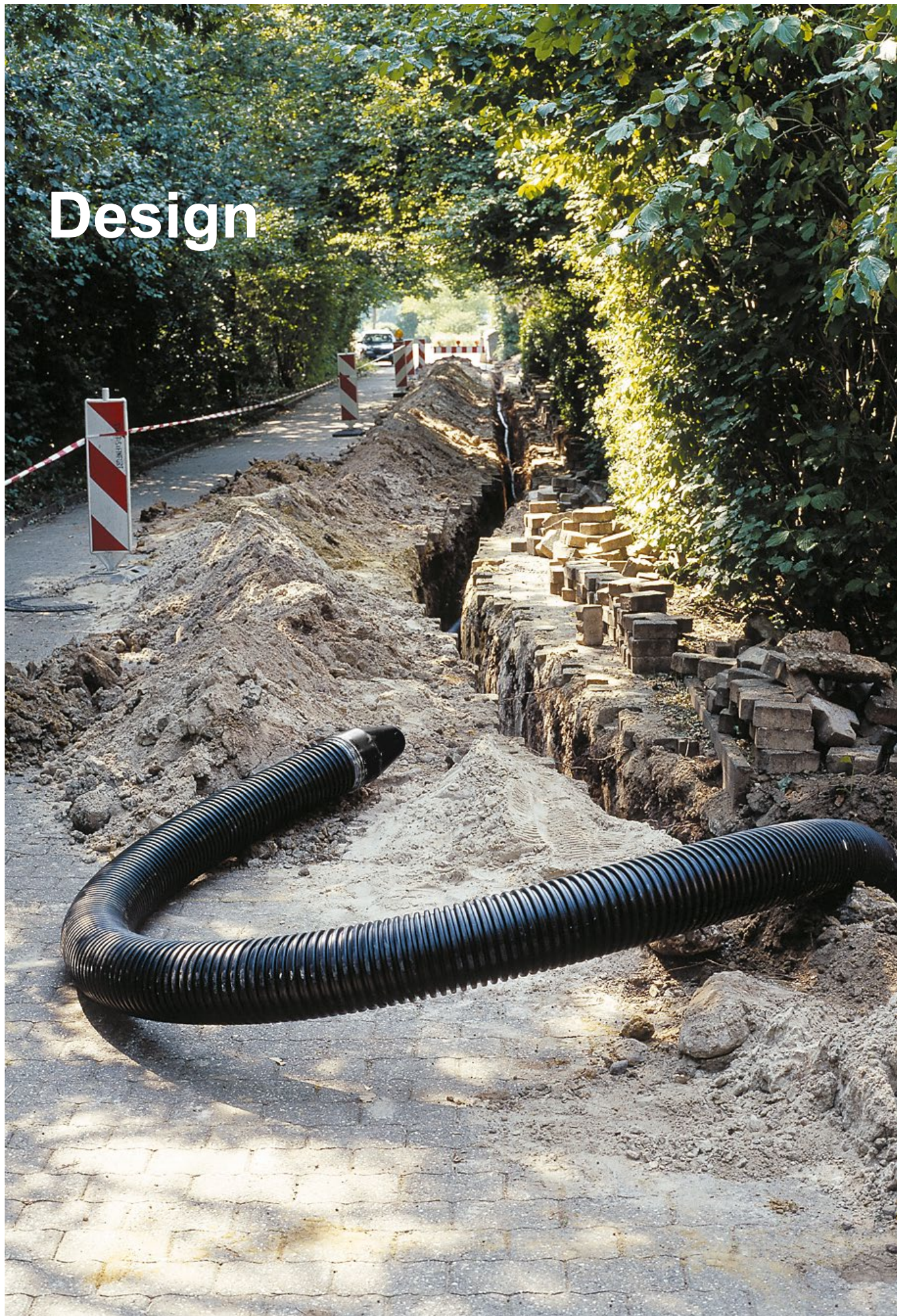



# Design

## Design basics

### Lining up the elements

The flexible piping system allows to plan the trenches flexibly and take the environment into account. When the pipe element is led into the building, the selection of the entry location must take into account the space requirements of the element bending radius.

### Linking

The implementation of the most profitable system in terms of operation and installation costs is best done using multiple pipe elements. Thermal loss is the least in the Quattro products, which are particularly well suited to implementation in terraced houses and small apartment buildings. The number of joints in

the ground can be reduced for small buildings by using the linking technique. The technique is particularly well suited to locations where houses are lined up and the dimensions of the Quattro products are adequate. The floor space required by Quattro is very small, allowing for linking joints to be made inside the apartments. For example, the raised base of the hallway cabinet can be used as the linking space.

### Building-specific lines

In properties consisting of several buildings, straight connections from the house to the boiler room are recommended if the boiler room is located in a central location.

Installation between buildings is fast straight off the coil and no connections are required. Trenches do not have to be kept open for pressure testing. The used pipe sizes are not large and this allows the use of multiple pipe elements.

### Combining products

Radiator-equipped hot tap water systems can be used with the larger circulation pipe elements Quattro and Aqua Twin. The benefits offered by twin and four-pipe elements can be taken advantage of in these locations. By combining products, a functional system can be created and efficient use of the chambers can be guaranteed.

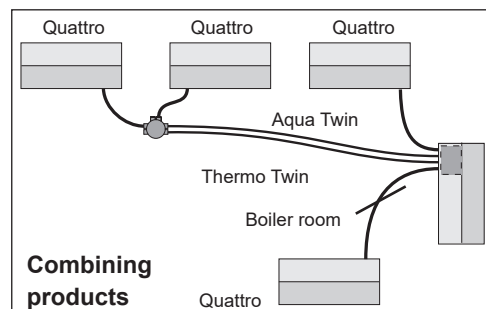
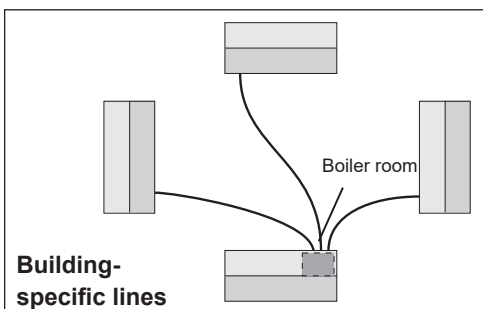
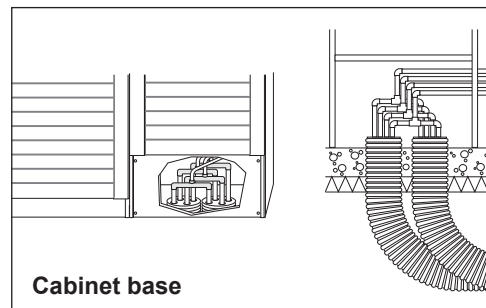
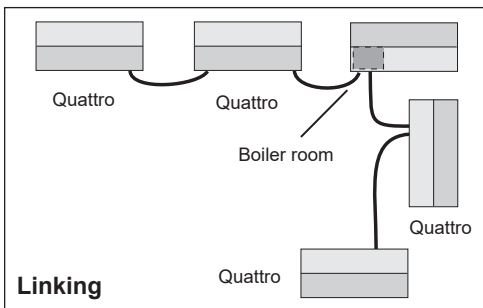

## Design the marked-out route

The flexibility of the Uponor pipes permits problem-free adaptation on-site to almost any routing conditions. It is possible to route over or under existing lines, while obstacles can simply be avoided. Even laying the pipe system under a groundwater table of 3 meter (0.3 bar) is permitted.

The system requires the excavation of only a narrow trench of low depth. Laying does not normally need anyone to get into the trench except at the pipe joint and branch locations. Suitable working space should be created for this purpose at the joint and branch sites. Whenever the pipe direction changes, the bending radii must not be smaller than the permitted minimums for the various pipe systems.

It is convenient to do all the excavation on one side of the trench. The pipe is then rolled out on the free side, and

laid directly in the trench. It is essential to avoid damaging the jacket pipe.

A bed of sand without stones is specified. The sand grain size should be between 0 and 2/3 mm. Never include any objects with sharp edges or points in the trench. Bedding the pipeline carefully (at least 10 cm above and below the jacket pipe, and to the walls of the ditch) has a crucial effect on the durability of the jacket pipe. When deciding the minimum coverage, the possibility of damage from subsequent building work during the entire lifetime of the construction should be borne in mind. The filling material should be compacted in layers, and a machine should be used for this above 500 mm coverage. When this has been done, lay the line warning strip and fill the trench.

When covered to a depth of  $h = 0.5$  metres up to a maximum



of 6 metres, the Uponor jacket pipe can withstand soil and high traffic loads. The certificate, based on ATV DVWK-A127, demonstrates that our pipes, when laid in accordance with defined conditions, are suitable

for loading by heavy traffic (SWL 60 = 60 t) according to worksheet ATV-A 127. The ring stiffness of the jacked pipe is proved according EN ISO 9969 to be able to withstand 4 kN/m<sup>2</sup> (class SN4).

### Minimum coverage without stress from traffic loading

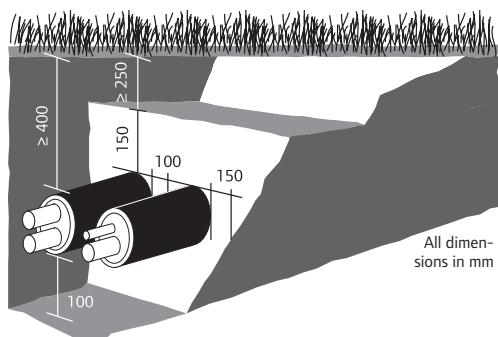

#### CAUTION!

Local frost limits have not been taken into account here.

### Coverage with traffic loading according to SLW 60 tons

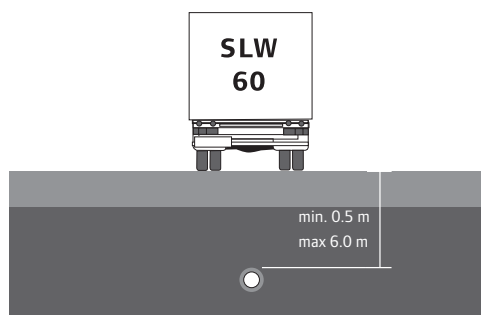







## Installation examples Uponor Ecoflex Thermo, Thermo PRO, Varia









Blue = Uponor Ecoflex Thermo PRO  
Green = Uponor Ecoflex Thermo

### 1 House connection with Uponor Ecoflex Thermo Twin

#### A Wall duct, non-pressure-waterproof (NPW)

Item	Number required
Thermo Twin	
Thermo PRO Twin	
Varia Twin (alternative)	
Rubber end caps, Twin <b>Alternative with Thermo PRO</b>	1 
Wipex coupling	2 
Wipex sleeve	2 
Wall through sealing NPW	1 

#### B Alternative: Wall duct, non-pressure-waterproof (NPW)

Item	Number required
Thermo Twin	
Thermo PRO Twin	
Varia Twin (alternative)	
Rubber end caps, Twin <b>Alternative with Thermo PRO</b>	1 
Wipex coupling	2 
Wipex sleeve	2 
Wall sleeve set NPW	1 







#### C Alternative: Wall duct, pressure-waterproof (PWP)

Item	Number required
Thermo Twin	
Thermo PRO Twin	
Varia Twin (alternative)	
Rubber end caps, Twin <b>Alternative with Thermo PRO</b>	1 
Wipex coupling	2 
Wipex sleeve	2 
Fibre cement pipe PWP *)	1 
Wall seal PWP	1 
Additional insert PWP *)	1 

\*) optional, check necessity

**2 Service connection with Uponor Ecoflex Thermo PRO Single**

Two wall ducts, non pressure-waterproof (NPW)

Item	Number required
Thermo Single	
Thermo PRO Single	
Varia Single (alternative)	
Rubber end caps, Single <b>Alternative with Thermo PRO</b>	2 
Wipex coupling	2 
Wipex sleeve	2 
Wall sleeve set NPW	2 

**3 Branching from Uponor Ecoflex Thermo PRO Single main lines to Thermo Twin branch lines in the H-insulation set**









Item	Number required
Thermo Single	
Thermo PRO Single	
Varia Single (alternative)	
Thermo Twin	
Thermo PRO Twin	
Varia Twin (alternative)	
Double tee	1 
Rubber end caps, Single <b>Alternative with Thermo PRO</b>	4 
Rubber end caps, Twin <b>Alternative with Thermo PRO</b>	1 
Wipex coupling	6 
Wipex tee	2 
Wipex reducer *)	

**4 Branching from Uponor Ecoflex Thermo PRO Single main lines to Thermo Twin branch lines in the chamber**







Item	Number required
Thermo Single	
Thermo PRO Single	
Varia Single (alternative)	
Thermo Twin	
Thermo PRO Twin	
Varia Twin (alternative)	
Chamber	1 
Rubber end caps, Single <b>Alternative with Thermo PRO</b>	4 
Rubber end caps, Twin <b>Alternative with Thermo PRO</b>	2 
Wipex coupling	8 
Wipex tee	4 
Wipex swivel union	2 
Wipex reducer *)	
Wipex elbow *)	

connecting pipe if necessary, pipe or double nipple (customer's responsibility)

**5 Uponor Ecoflex Thermo Twin branches in the T-insulation set**

Item	Number required
Thermo Twin	
Thermo PRO Twin	
Varia Twin (alternative)	
T-insulation set	1 
Rubber end caps, Twin	3 
Wipex coupling	6 
Wipex tee	2 
Wipex reducer *)	

**6 Uponor Ecoflex Thermo PRO Twin joints in the straight insulation set**

Item	Number required
Thermo Twin	
Thermo PRO Twin	
Varia Twin (alternative)	
Straight insulation set	1 
Rubber end caps, Twin	2 
Wipex coupling	4 
Wipex sleeve	2 

\*) optional, check necessity



## Installation examples Uponor Ecoflex Aqua

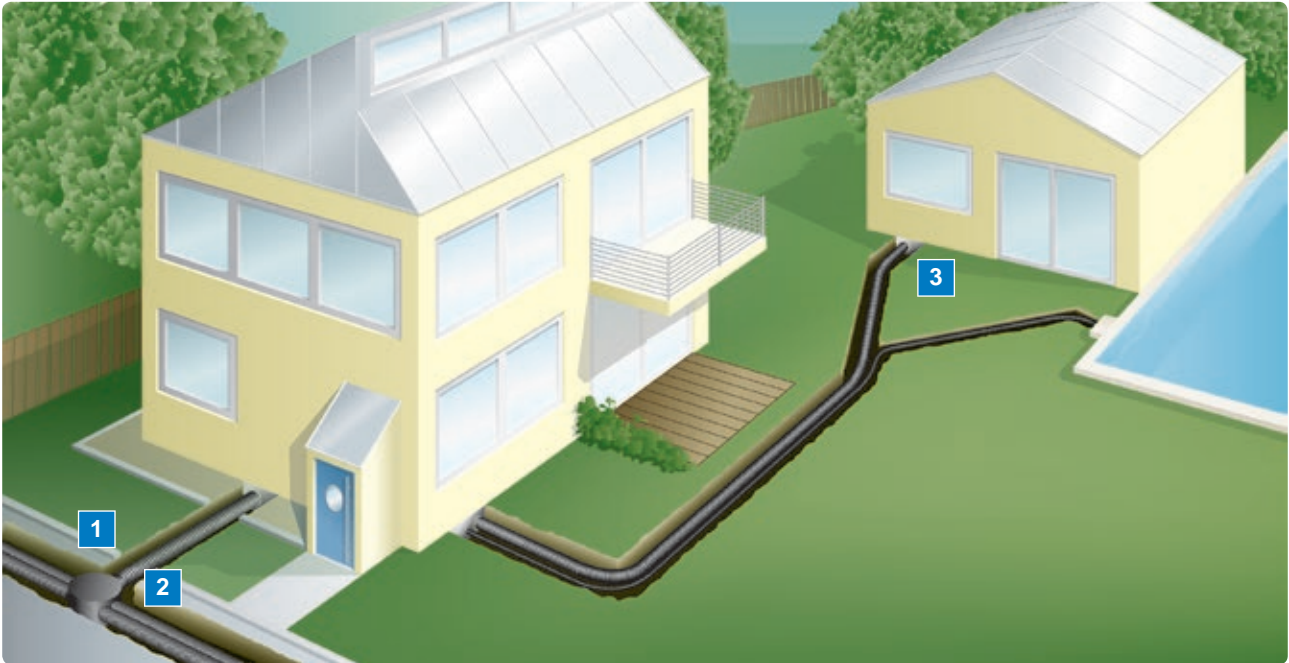

### 1 Branching from Uponor Ecoflex Aqua Single main lines to Aqua Twin branch lines in the chamber

Item	Number required	Image
Aqua Single		
Aqua Twin		
Chamber	1	
Rubber end caps, Single	4	
Rubber end caps, Twin	1	
WIPEX coupling 10 bar	6	
WIPEX tee	2	
WIPEX reducer *)		
WIPEX bend *)		

connecting pipe if necessary,  
pipe or double nipple  
(customer's responsibility)

### 2 Alternative: Uponor Ecoflex Aqua Twin branches in the T-insulation set

Item	Number required	Image
Aqua Twin		
Aqua Midi Twin (alternative)		
T-insulation set	1	
Rubber end caps, Twin	3	
WIPEX coupling 10 bar	6	
WIPEX tee	2	
WIPEX reducer *)		

### 3 Service connection with Uponor Ecoflex Aqua Twin

Wall duct, non-pressure-waterproof (NPW)

Item	Number required	Image
Aqua Twin		
Aqua Midi Twin (alternative)		
Rubber end caps Twin	1	
WIPEX coupling 10 bar	2	
WIPEX sleeve	2	
Wall through sealing	1	





\*) optional, check necessity

## Installation examples Uponor Ecoflex Quattro







### Service connection with Uponor Ecoflex Quattro







#### 1 Wall duct, non-pressure-waterproof (NPW)

Item	Number required
Quattro	
Rubber end caps, Quattro	1 
WIPEX coupling 6 bar + 10 bar	4 
WIPEX sleeve	4 
Wall through sealing NPW	1 

#### 2 Alternative: Wall duct, non-pressure-waterproof (NPW)

Item	Number required
Quattro	
Rubber end caps, Quattro	2 
Wipex coupling 6 bar + 10 bar	8 
Wipex sleeve	8 
Wall sleeve sleeve set NPW	2 

#### 3 Alternative: Wall duct, pressure-waterproof (PWP)

Item	Number required
Quattro	
Rubber end caps, Quattro	1 
WIPEX coupling 6 bar + 10 bar	4 
WIPEX sleeve	4 
Fibre cement pipe PWP *)	1 
Wall seal PWP	1 
Supplementary kit PWP *)	1 

\*) optional, check necessity



# Dimensioning

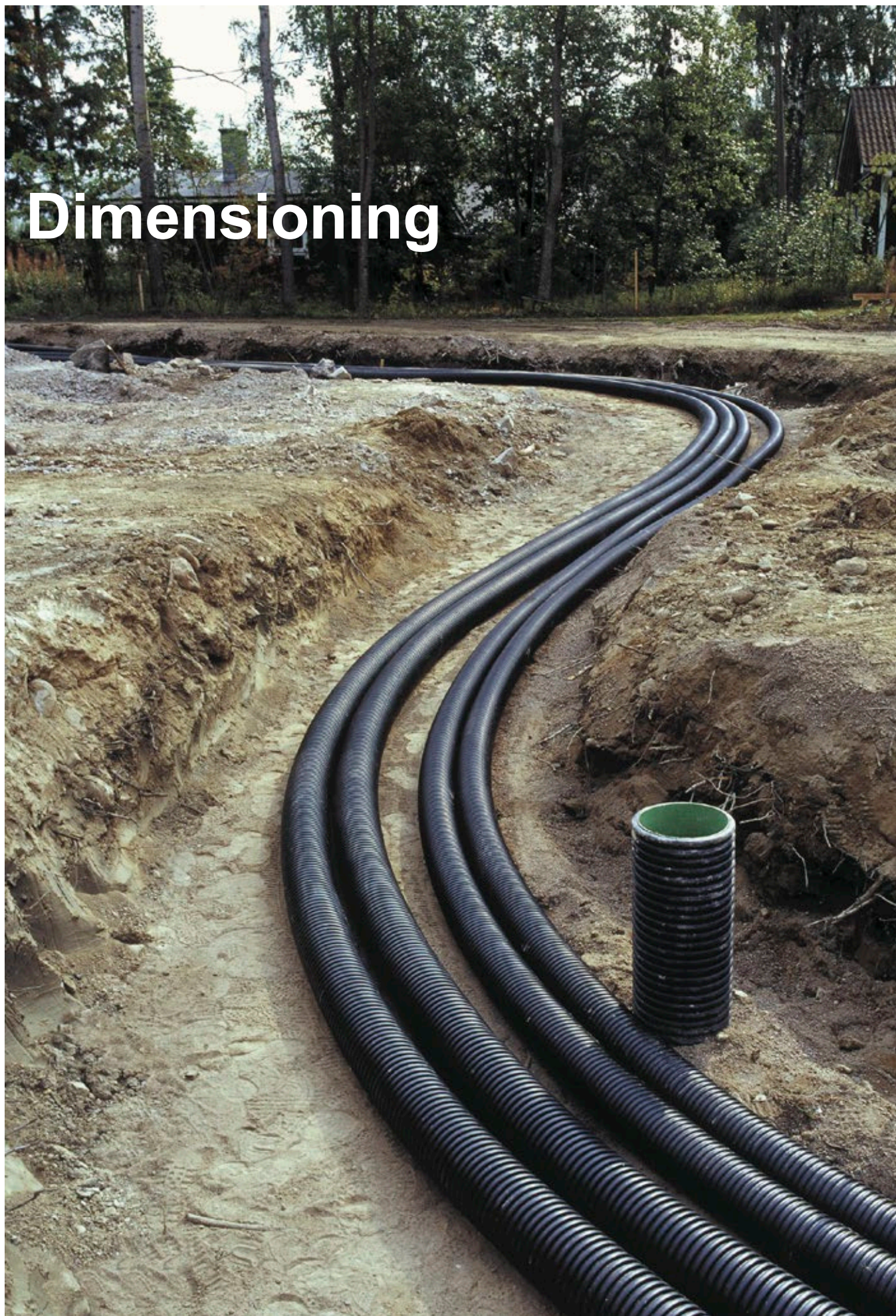



# Dimensioning

## Pressure loss tables for PN 6 pipes

Heating pipe: Based on 50 °C water temperature\*

DIM: d <sub>i</sub> [mm]:	25 x 2.3 20.4	32 x 2.9 26.2	40 x 3.7 32.6	50 x 4.6 40.8	63 x 5.8 51.4	75 x 6.8 61.4	90 x 8.2 73.6	110 x 10 90.0	125 x 11.4 102.2										
Volumetric flow rate	kPa/m		kPa/m		kPa/m		kPa/m		kPa/m		kPa/m		kPa/m		kPa/m				
	l/h	l/s	m/s	m/s	m/s	m/s	m/s	m/s	m/s	m/s	m/s	m/s	m/s	m/s	m/s	m/s			
36	0.01																		
72	0.02																		
108	0.03																		
144	0.04																		
180	0.05	0.018	0.153																
216	0.06	0.025	0.184																
252	0.07	0.033	0.214																
288	0.08	0.042	0.245																
324	0.09	0.051	0.275																
360	0.1	0.062	0.306	0.019	0.185														
720	0.2	0.214	0.612	0.065	0.371	0.023	0.240												
1080	0.3	0.444	0.918	0.134	0.556	0.047	0.359												
1440	0.4	0.745	1.224	0.224	0.742	0.079	0.479	0.027	0.306										
1800	0.5	1.114	1.530	0.335	0.927	0.117	0.599	0.040	0.382										
2160	0.6	1.548	1.836	0.465	1.113	0.163	0.719	0.056	0.459										
2520	0.7	2.044	2.142	0.614	1.298	0.215	0.839	0.073	0.535										
2880	0.8	2.601	2.448	0.782	1.484	0.274	0.958	0.093	0.612	0.031	0.386								
3240	0.9	3.217	2.754	0.967	1.669	0.338	1.078	0.115	0.688	0.038	0.434								
3600	1	3.891	3.059	1.169	1.855	0.409	1.198	0.139	0.765	0.046	0.482								
3960	1.1	4.623	3.665	1.389	2.040	0.486	1.318	0.165	0.841	0.055	0.530								
4320	1.2	5.411	3.671	1.625	2.226	0.568	1.438	0.193	0.918	0.064	0.578	0.027	0.405						
5040	1.4	7.152	4.283	2.147	2.597	0.751	1.677	0.255	1.071	0.084	0.675	0.036	0.473						
5760	1.6	9.108	4.895	2.733	2.968	0.956	1.917	0.325	1.224	0.107	0.771	0.046	0.540						
6480	1.8	11.274	5.507	3.383	3.339	1.182	2.156	0.402	1.377	0.133	0.867	0.056	0.608	0.024	0.423				
7200	2	13.647	6.119	4.093	3.710	1.431	2.396	0.486	1.530	0.160	0.964	0.068	0.675	0.029	0.470				
7920	2.2	16.223	6.731	4.865	4.081	1.700	2.636	0.578	1.683	0.190	1.060	0.081	0.743	0.034	0.517				
8640	2.4	18.998	7.343	5.696	4.452	1.990	2.875	0.676	1.836	0.223	1.157	0.095	0.811	0.040	0.564				
9360	2.6	21.969	7.955	6.586	4.823	2.300	3.115	0.782	1.989	0.257	1.253	0.110	0.878	0.046	0.611				
10080	2.8	25.134	8.567	7.533	5.194	2.631	3.355	0.894	2.142	0.294	1.349	0.125	0.946	0.052	0.658				
10800	3	28.491	9.178	8.538	5.565	2.981	3.594	1.013	2.295	0.334	1.446	0.142	1.013	0.059	0.705	0.023	0.472		
12600	3.5	37.707	10.708	11.295	6.492	3.943	4.193	1.339	2.677	0.441	1.687	0.187	1.182	0.078	0.823	0.030	0.550		
14400	4	48.077	12.238	14.397	7.419	5.024	4.792	1.706	3.059	0.561	1.928	0.239	1.351	0.100	0.940	0.038	0.629	0.021	0.488
16200	4.5			17.835	8.347	6.223	5.391	2.112	3.442	0.695	2.169	0.295	1.520	0.124	1.058	0.047	0.707	0.025	0.549
18000	5			21.603	9.274	7.536	5.990	2.557	3.824	0.841	2.410	0.358	1.689	0.150	1.175	0.057	0.786	0.031	0.610
19800	5.5			25.696	10.202	8.962	6.589	3.041	4.207	1.000	2.651	0.425	1.858	0.178	1.293	0.068	0.865	0.037	0.670
21600	6			30.109	11.129	10.499	7.188	3.561	4.589	1.171	2.892	0.498	2.026	0.208	1.410	0.079	0.943	0.043	0.731
23400	6.5			34.837	12.056	12.145	7.787	4.119	4.972	1.354	3.133	0.575	2.195	0.240	1.528	0.091	1.022	0.050	0.792
25200	7					13.900	8.386	4.713	5.354	1.549	3.374	0.658	2.364	0.275	1.645	0.104	1.100	0.057	0.853
27000	7.5					15.761	8.985	5.344	5.737	1.756	3.614	0.746	2.533	0.312	1.763	0.118	1.179	0.064	0.914
28800	8					17.728	9.584	6.010	6.119	1.975	3.855	0.839	2.702	0.350	1.880	0.133	1.258	0.072	0.975
30600	8.5					19.799	10.183	6.711	6.501	2.205	4.096	0.936	2.871	0.391	1.998	0.149	1.336	0.081	1.036
32400	9					21.974	10.782	7.447	6.884	2.446	4.337	1.039	3.040	0.434	2.115	0.165	1.415	0.089	1.097

Heating pipe: Based on 50 °C water temperature\*

DIM: d <sub>i</sub> [mm]:	25 x 2.3 20.4	32 x 2.9 26.2	40 x 3.7 32.6	50 x 4.6 40.8	63 x 5.8 51.4	75 x 6.8 61.4	90 x 8.2 73.6	110 x 10 90.0	125 x 11.4 102.2									
Volumetric flow rate																		
	l/h	l/s	kPa/m	m/s	kPa/m	m/s	kPa/m	m/s	kPa/m	m/s	kPa/m	m/s	kPa/m	m/s	kPa/m	m/s	kPa/m	m/s
34200	9.5				24.252	11.381	8.218	7.266	2.699	4.578	1.146	3.208	0.479	2.233	0.182	1.493	0.099	1.158
36000	10				26.632	11.980	9.023	7.649	2.963	4.819	1.258	3.377	0.525	2.350	0.199	1.572	0.108	1.219
37800	10.5						9.862	8.031	3.238	5.060	1.375	3.546	0.574	2.468	0.218	1.650	0.118	1.280
39600	11						10.735	8.414	3.525	5.301	1.496	3.715	0.625	2.586	0.237	1.729	0.129	1.341
43200	12						12.582	9.178	4.130	5.783	1.753	4.053	0.732	2.821	0.278	1.886	0.151	1.463
46800	13						14.561	9.943	4.779	6.265	2.028	4.391	0.847	3.056	0.321	2.043	0.174	1.585
50400	14						116.670	10.708	5.470	6.747	2.321	4.728	0.969	3.291	0.367	2.201	0.199	1.707
54000	15						18.909	11.473	6.204	7.229	2.632	5.066	1.098	3.526	0.417	2.358	0.226	1.829
57600	16						21.276	12.238	6.979	7.711	2.960	5.404	1.235	3.761	0.468	2.515	0.254	1.950
61200	17								7.796	8.193	3.306	5.741	1.380	3.996	0.523	2.672	0.283	2.072
64800	18								8.653	8.675	3.670	6.079	1.531	4.231	0.580	2.829	0.315	2.194
68400	19								9.552	9.157	4.050	6.417	1.690	4.466	0.640	2.987	0.347	2.316
72000	20								10.490	9.639	4.448	6.755	1.855	4.701	0.703	3.144	0.381	2.438
79200	22								12.487	10.602	5.293	7.430	2.208	5.171	0.837	3.458	0.453	2.682
86400	24								14.641	11.566	6.206	8.106	2.587	5.641	0.980	3.773	0.531	2.926
93600	26								16.951	12.530	7.183	8.781	2.995	6.111	1.134	4.087	0.614	3.169
100800	28										8.226	9.457	3.429	6.581	1.299	4.401	0.703	3.413
108000	30										9.333	10.132	3.890	7.051	1.473	4.716	0.798	3.657
115200	32										10.503	10.807	4.377	7.522	1.657	5.030	0.897	3.901
122400	34										11.736	11.483	4.890	7.992	1.851	5.344	1.002	4.145
129600	36										13.032	12.158	5.429	8.462	2.055	5.659	1.113	4.388
136800	38											5.994	8.932	2.269	5.973	1.228	4.632	
144000	40											6.584	9.402	2.492	6.288	1.349	4.876	
162000	45											8.170	10.577	3.091	7.074	1.673	5.486	
180000	50											9.911	11.752	3.749	7.860	2.029	6.095	
198000	55											11.805	12.928	4.464	8.645	2.415	6.705	
216000	60												5.236	9.431	2.833	7.314		
234000	65												6.064	10.217	3.280	7.924		
252000	70												6.948	11.003	3.758	8.533		
270000	75												7.886	11.789	4.265	9.143		
288000	80												8.878	12.575	4.801	9.752		
306000	85														5.366	10.362		
324000	90														5.960	10.971		
342000	95														6.583	11.581		
360000	100														7.233	12.190		

\*Pressure loss correction factors for other water temperatures

°C	10	15	20	25	30	35	40	45	50	55	60	65	70	75	80	85	90	95
Factor	1.217	1.183	1.150	1.117	1.100	1.067	1.050	1.017	1.000	0.983	0.967	0.952	0.938	0.933	0.918	0.904	0.890	0.873



Pressure loss diagram heating pipe 70 °C\*

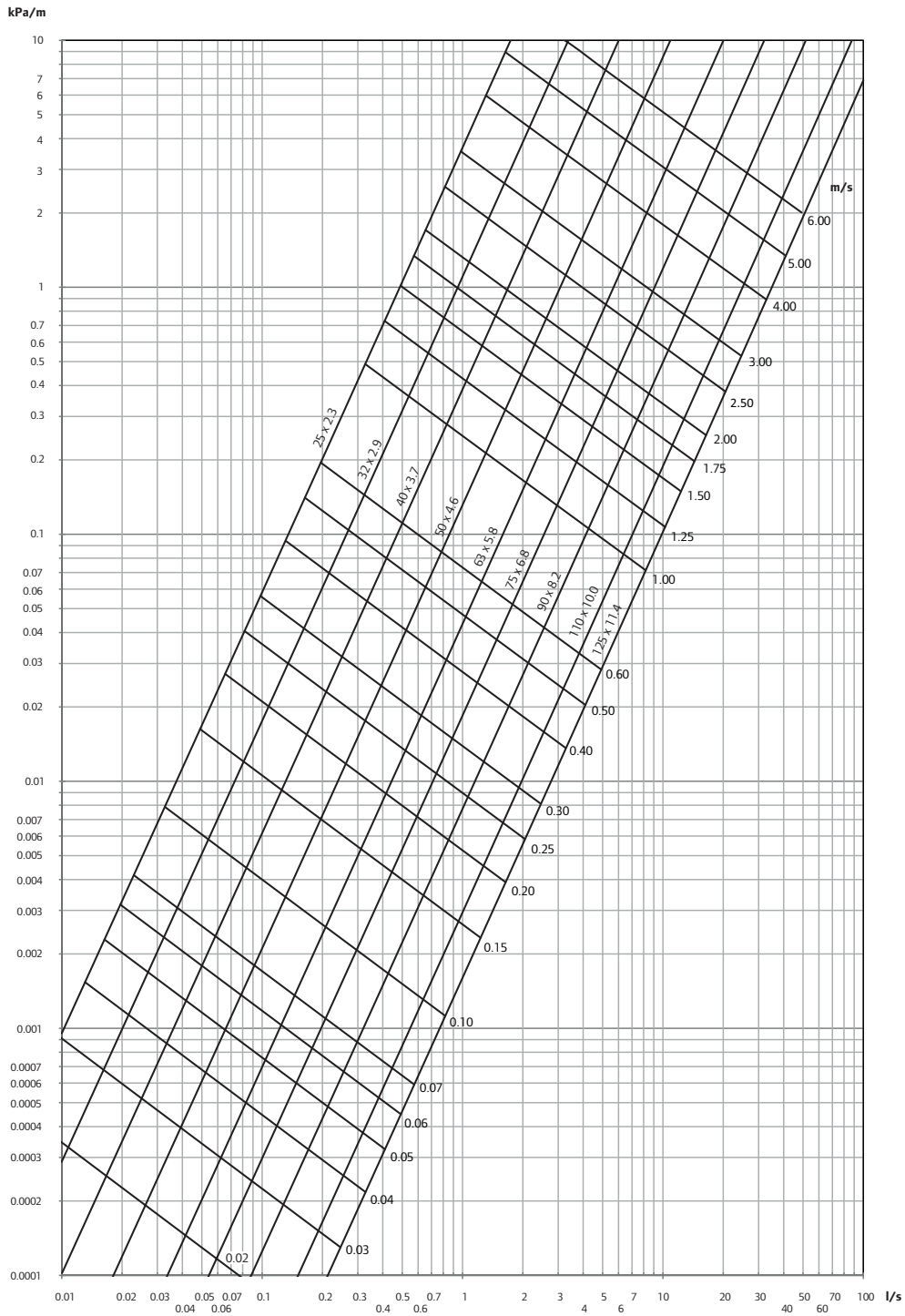

\* Pressure loss correction factors for other water temperatures

Temperature °C	90	80	70	60	50	40	30	20
Factor	0.95	0.98	1.00	1.02	1.05	1.10	1.14	1.20

## Pressure loss table for PN 10 pipes

Heating pipe: Based on 50 °C water temperature\*

Nom. Dim.	18x2,5	20x2,8	22x3,0	25x3,5	28x4,0	32x4,4	40x5,5	50x6,9	63x8,7	75x10,3	90x12,3	110x15,1													
ID (mm)	(13)	(14,4)	(16)	(18)	(20,0)	(23,2)	(29)	(36,2)	(45,6)	(54,4)	(65,4)	(79,8)													
Volumetric flow rate																									
l/h	l/s	kPa/m	m/s	kPa/m	m/s	kPa/m	m/s	kPa/m	m/s	kPa/m	m/s	kPa/m	m/s	kPa/m	m/s	kPa/m	m/s	kPa/m	m/s	kPa/m	m/s	kPa/m	m/s		
36	0,01			0,005	0,061	0,003	0,050																		
72	0,02	0,030	0,151	0,018	0,123	0,011	0,099																		
108	0,03	0,062	0,226	0,038	0,184	0,023	0,149																		
144	0,04	0,104	0,301	0,064	0,246	0,038	0,199																		
180	0,05	0,155	0,377	0,095	0,307	0,057	0,249	0,033	0,196																
216	0,06	0,215	0,452	0,132	0,368	0,079	0,298	0,045	0,236	0,027	0,191														
252	0,07	0,283	0,527	0,173	0,430	0,105	0,348	0,060	0,275	0,036	0,223														
288	0,08	0,359	0,603	0,220	0,491	0,133	0,398	0,076	0,314	0,046	0,255														
324	0,09	0,444	0,678	0,272	0,553	0,164	0,448	0,093	0,354	0,056	0,286	0,028	0,213												
360	0,1	0,536	0,753	0,328	0,614	0,198	0,497	0,113	0,393	0,068	0,318	0,033	0,237												
720	0,2	1,862	1,507	1,140	1,228	0,688	0,995	0,391	0,786	0,236	0,637	0,116	0,473	0,040	0,303										
1080	0,3	3,863	2,260	2,364	1,848	1,426	1,492	0,810	1,179	0,489	0,955	0,240	0,710	0,082	0,454	0,028	0,291								
1440	0,4	6,487	3,014	3,969	2,456	2,393	1,989	1,360	1,572	0,820	1,273	0,402	0,946	0,138	0,606	0,048	0,389								
1800	0,5	9,703	3,767	5,936	3,070	3,578	2,487	2,032	1,965	1,225	1,592	0,601	1,183	0,206	0,757	0,071	0,486	0,023	0,306						
2160	0,6	13,486	4,520	8,249	3,684	4,972	2,984	2,823	2,358	1,702	1,910	0,834	1,419	0,286	0,908	0,099	0,583	0,033	0,367						
2520	0,7	17,819	5,274	10,898	4,298	6,568	3,482	3,729	2,751	2,248	2,228	1,102	1,656	0,377	1,060	0,130	0,680	0,043	0,429	0,018	0,301				
2880	0,8	22,687	6,027	13,873	4,912	8,360	3,979	4,746	3,144	2,860	2,546	1,402	1,892	0,480	1,211	0,165	0,777	0,055	0,490	0,023	0,344				
3240	0,9	28,077	6,781	17,167	5,526	10,343	4,476	5,871	3,537	3,538	2,865	1,734	2,129	0,593	1,363	0,205	0,874	0,068	0,551	0,029	0,387				
3600	1,0	33,978	7,534	20,773	6,140	12,515	4,974	7,103	3,930	4,280	3,183	2,097	2,366	0,718	1,514	0,247	0,972	0,082	0,612	0,035	0,430				
3960	1,1	40,381	8,287	24,686	6,754	14,871	5,471	8,439	4,323	5,085	3,501	2,491	2,602	0,852	1,665	0,294	1,069	0,097	0,674	0,042	0,473				
4320	1,2	47,279	9,041	28,901	7,368	17,408	5,968	9,878	4,716	5,951	3,820	2,915	2,839	0,997	1,817	0,344	1,166	0,113	0,735	0,049	0,516				
5040	1,4	62,529	10,548	38,217	8,596	23,016	6,963	13,059	5,502	7,866	4,456	3,853	3,312	1,318	2,120	0,454	1,360	0,150	0,857	0,064	0,602				
5760	1,6	79,677	12,054	48,691	9,824	29,320	7,958	16,633	6,288	10,018	5,093	4,906	3,785	1,677	2,422	0,578	1,555	0,190	0,980	0,082	0,688	0,034	0,476		
6480	1,8		60,298	11,052	36,305	8,952	20,593	7,074	12,402	5,730	6,072	4,258	2,076	2,725	0,715	1,749	0,236	1,102	0,101	0,774	0,042	0,536			
7200	2,0		73,014	12,280	43,957	9,947	24,930	7,860	15,012	6,366	7,349	4,731	2,512	3,028	0,865	1,943	0,285	1,225	0,122	0,860	0,050	0,595			
7920	2,2			86,821	13,509	52,264	10,942	29,638	8,645	17,845	7,003	8,735	5,204	2,985	3,331	1,027	2,138	0,339	1,347	0,145	0,947	0,060	0,655		
8640	2,4			101,702	14,737	61,217	11,937	34,711	9,431	20,898	7,639	10,228	5,677	3,494	3,634	1,202	2,332	0,396	1,470	0,170	1,033	0,070	0,714		
9360	2,6				70,805	12,931	40,144	10,217	24,167	8,276	11,826	6,150	4,040	3,936	1,390	2,526	0,458	1,592	0,196	1,119	0,081	0,774	0,031	0,520	
10080	2,8					81,021	13,926	45,932	11,003	27,650	8,913	13,529	6,624	4,621	4,239	1,589	2,721	0,524	1,715	0,224	1,205	0,092	0,834	0,036	0,560
10800	3,0					91,857	14,921	52,071	11,789	31,343	9,549	15,334	7,097	5,236	4,542	1,801	2,915	0,593	1,837	0,254	1,291	0,105	0,893	0,040	0,600
12600	3,5					121,616	17,408	68,928	13,754	41,483	11,141	20,290	8,279	6,927	5,299	2,382	3,401	0,784	2,143	0,336	1,506	0,138	1,042	0,053	0,700
14400	4,0						87,901	15,719	52,893	12,732	25,866	9,462	8,828	6,056	3,034	3,886	0,999	2,449	0,427	1,721	0,176	1,191	0,068	0,800	
16200	4,5						108,943	17,684	65,546	14,324	32,048	10,645	10,934	6,813	3,757	4,372	1,237	2,755	0,529	1,936	0,218	1,340	0,084	0,900	
18000	5,0						132,016	19,649	79,419	15,915	38,825	11,828	13,243	7,570	4,550	4,858	1,497	3,062	0,640	2,151	0,264	1,488	0,101	1,000	
19800	5,5							94,492	17,507	46,187	13,011	15,751	8,327	5,410	5,344	1,780	3,368	0,791	2,366	0,314	1,637	0,120	1,100		
21600	6,0							110,747	19,099	54,124	14,193	18,454	9,084	6,337	5,830	2,084	3,674	0,891	2,581	0,367	1,786	0,141	1,200		
23400	6,5							128,167	20,690	62,630	15,376	21,350	9,841	7,331	6,315	2,410	3,980	1,030	2,797	0,425	1,935	0,163	1,300		
25200	7,0								71,696	16,559	24,437	10,598	8,389	6,801	2,758	4,286	1,179	3,012	0,486	2,084	0,186	1,400			
27000	7,5								81,318	17,742	27,712	11,355	9,512	7,287	3,127	4,592	1,336	3,227	0,550	2,233	0,211	1,500			
28800	8,0								91,487	18,924	31,172	12,112	10,698	7,773	3,516	4,899	1,502	3,442	0,619	2,381	0,237	1,600			
30600	8,5								102,200	20,107	34,817	12,869	11,947	8,259	3,926	5,205	1,677	3,657	0,691	2,530	0,265	1,700			
32400	9,0								113,452	21,290	38,645	13,626	13,259	8,745	4,356	5,511	1,861	3,872	0,766	2,679	0,294	1,799			
34200	9,5									42,654	14,383	14,632	9,230	4,807	5,817	2,054	4,087	0,846	2,828	0,324	1,899				
36000	10,0									46,842	15,140	16,067	9,716	5,278	6,123	2,254	4,302	0,928	2,977	0,356	1,999				
37800	10,5									51,207	15,897	17,562	10,202	5,768	6,429	2,464	4,518	1,014	3,126	0,389	2,099				
39600	11,0									55,750	16,654	19,118	10,688	6,278	6,736	2,681	4,733	1,104	3,275	0,423	2,199				
43200	12,0									65,360	18,168	22,409	11,659	7,358	7,348	3,142	5,163	1,293	3,572	0,496	2,399				
46800	13,0									75,663	19,681	25,936	12,631	8,514	7,960	3,635	5,593	1,496	3,870	0,573	2,599				
50400	14,0									86,650	21,195	29,697	13,603	9,747	8,573	4,161	6,023	1,712	4,168	0,656	2,799				
54000	15,0									98,313	22,709	33,688	14,574	11,055	9,185	4,718	6,454	1,941	4,465	0,744	2,999				
57600	16,0									110,646	24,223	37,908	15,546	12,437	9,797	5,308	6,884	2,184	4,763	0,836	3,199				
61200	17,0									123,642	25,737	42,534	16,517	13,894	10,409	5,929	7,314	2,439	5,061	0,934	3,399				
79200	22,0										67,910	21,375	22,262	13,471	9,495	9,465	3,903	6,549	1,494	4,399					
86400	24,0										79,654	23,319	26,106	14,696	11,133	10,326	4,576	7,144	1,751	4,799					
93600	26,0											92,250	25,262	30,228	15,920	12,888	11,186	5,297	7,740	2,027	5,198				

Nom. Dim.	18x2,5	20x2,8	22x3,0	25x3,5	28x4,0	32x4,4	40x5,5	50x6,9	63x8,7	75x10,3	90x12,3	110x15,1										
ID (mm)	(13)	(14,4)	(16)	(18)	(20,0)	(23,2)	(29)	(36,2)	(45,6)	(54,4)	(65,4)	(79,8)										
<b>Volumetric flow rate</b>																						
l/h	l/s	kPa/m	m/s	kPa/m	m/s	kPa/m	m/s	kPa/m	m/s	kPa/m	m/s	kPa/m	m/s	kPa/m	m/s	kPa/m	m/s	kPa/m	m/s	kPa/m	m/s	
100800	28,0									105,688	27,205	34,624	17,145	14,761	12,047	6,065	8,335	2,321	5,598			
108000	30,0									119,960	29,148	39,292	18,370	16,748	12,907	6,881	8,931	2,632	5,998			
115200	32,0											44,229	19,594	18,850	13,768	7,743	9,526	2,962	6,398			
122400	34,0											49,432	20,819	21,065	14,628	8,652	10,121	3,309	6,798			
129600	36,0											54,900	22,044	23,392	15,489	9,607	10,717	3,674	7,198			
136800	38,0											60,630	23,268	25,831	16,349	10,607	11,312	4,056	7,598			
144000	40,0											66,619	24,493	28,379	17,210	11,652	11,907	4,455	7,998			
162000	45,0											82,719	27,555	35,229	19,361	14,461	13,396	5,527	8,997			
180000	50,0											100,405	30,616	42,751	21,512	17,544	14,884	6,704	9,997			
198000	55,0											119,655	33,678	50,937	23,663	20,899	16,373	7,984	10,997			
216000	60,0											59,778	25,814	24,522	17,861	9,366	11,997					
234000	65,0											69,264	27,966	28,408	19,349	10,849	12,996					
252000	70,0											79,391	30,117	32,556	20,838	12,430	13,996					
270000	75,0											90,150	32,268	36,962	22,326	14,110	14,996					
288000	80,0											101,536	34,419	41,624	23,815	15,888	15,995					

**\*Pressure loss correction factors for other water temperatures**

°C	10	15	20	25	30	35	40	45	50	55	60	65	70	75	80	85	90	95
<b>Factor</b>	1.208	1.174	1.144	1.115	1.087	1.060	1.039	1.019	1.000	0.982	0.965	0.954	0.943	0.928	0.923	0.907	0.896	0.878

Pressure loss diagram heating pipe at 70 °C\*

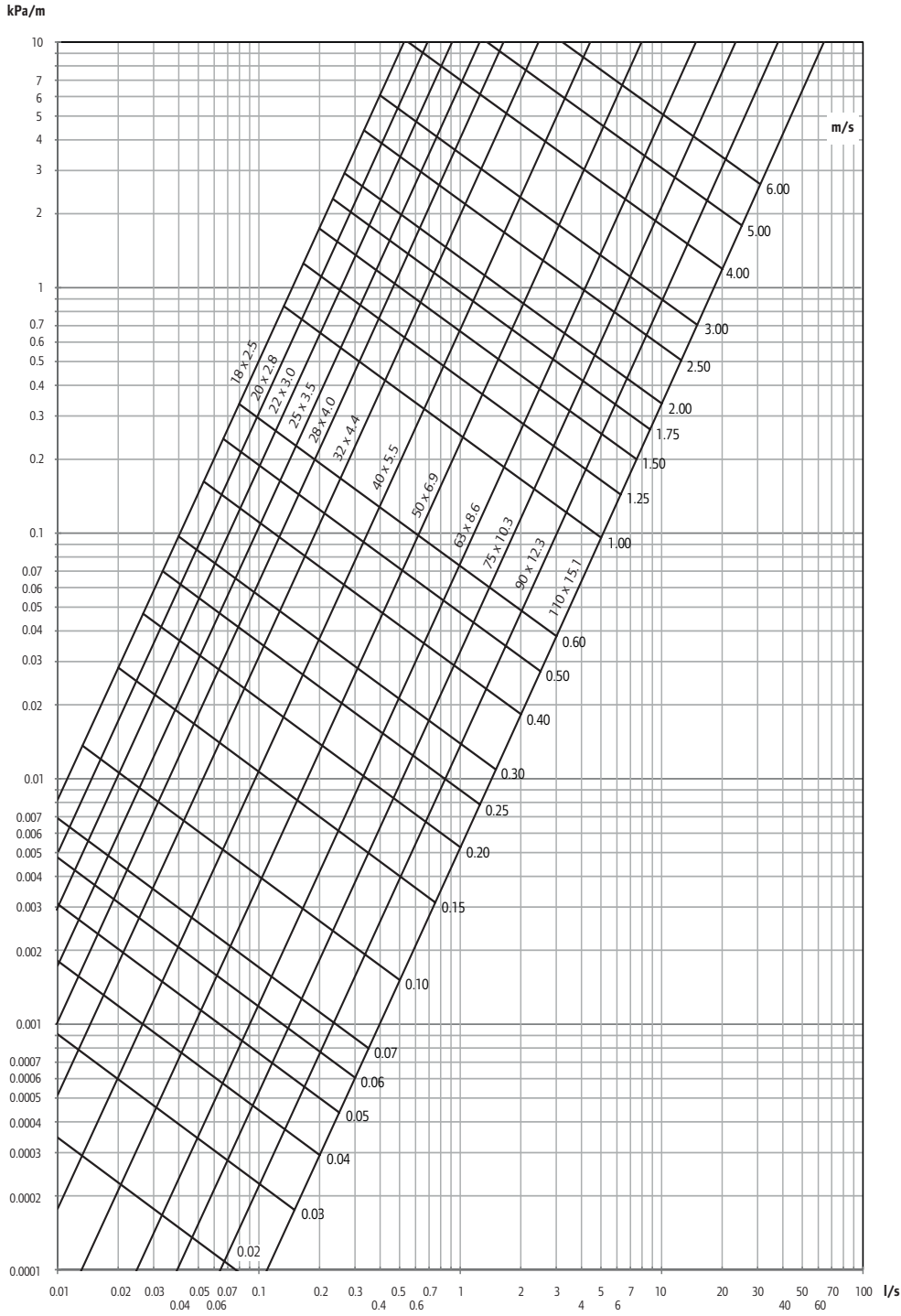

\* Pressure loss correction factors for other water temperatures

Temperature °C	90	80	70	60	50	40	30	20
Factor	0.95	0.98	1.00	1.02	1.05	1.10	1.14	1.20

## Dimensioning heating basics

If required, the use of a considerably larger pressure loss per meter is possible when dimensioning plastic heating pipes than when dimensioning steel pipes. There are no

limitations to stream velocity, because plastic pipes do not erode. The recommended pressure loss area has been darkened. The diagram includes rated values  $\Delta\theta$  20, 45 and 30

for changes in temperature. The size can also be selected according to the mass flow rate. The required mass flow rate can be calculated using a formula.

$$\dot{m} = \frac{Q}{D\theta \cdot c_p}$$

where

- $\dot{m}$  = mass flow rate kg/s
- $Q$  = heating power kW
- $D\theta$  = temperature difference K
- $c_p$  = water specific heat capacity 4,19 kJ/kgK

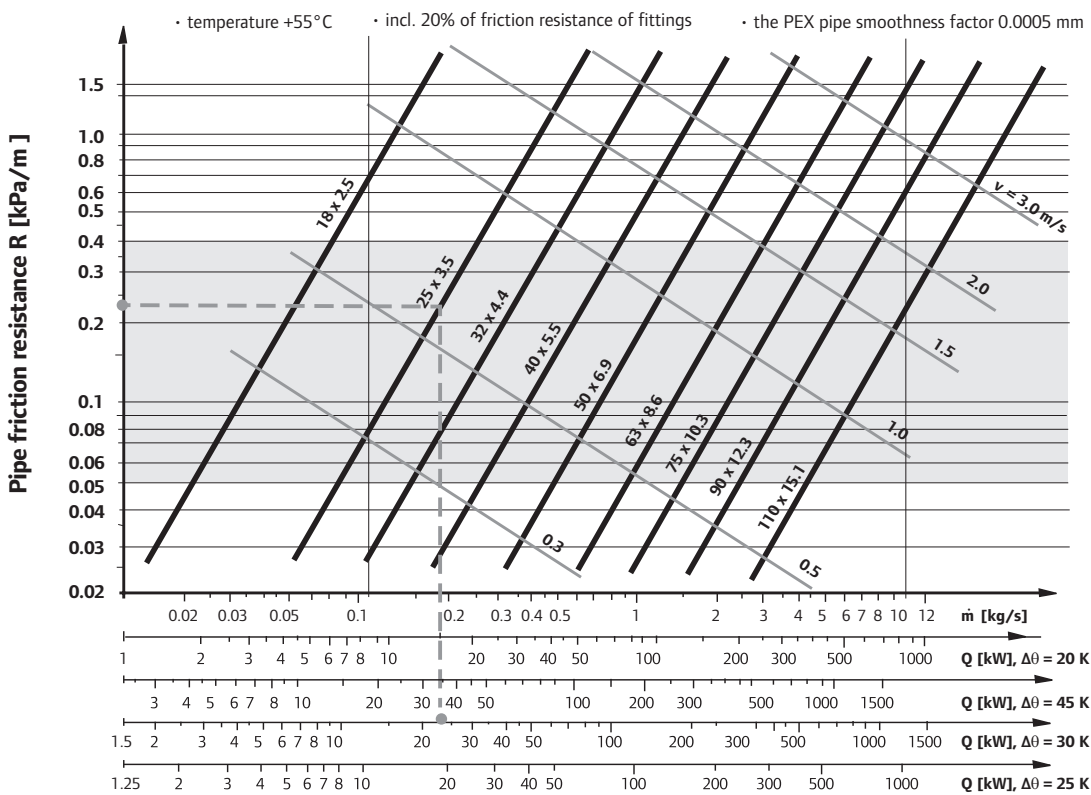

### Dimensioning example:

The task is to select heating pipes and the boiler house.

The surface area of the building is 300 m<sup>2</sup> and the room height is 2.9 m. The building has normal radiator heating with flow water temperature  $\theta_1 = +70$  °C and return water  $\theta_2 = +40$  °C.

#### Phase 1

Determine the requirement for heating power (the volume of the building times the specific capacity requirement).

$$F = 300 \text{ m}^2 \times 2.9 \text{ m} \times 25 \text{ W/m}^3 = 21750 \text{ W} \approx 22 \text{ kW}$$

#### Phase 2

Determine the correct  $\Delta\theta$ -axle or mass flow rate.

$$\Delta\theta = (\theta_1 - \theta_2) = 30 \text{ K}$$

#### Phase 3

Select the correct pipe size from the recommended pressure loss area set out in the image.

$$\Delta\theta = 30 \text{ K and } Q = 22 \text{ kW} \Rightarrow$$

Pipe size  $\varnothing$  25/20.4 mm

#### Specific heating power requirements [W/m<sup>3</sup>]

One-family house	Terraced house	Apartment building	
12 – 18	12 – 18	10 – 16	new
18 – 26	18 – 26	16 – 23	old

## Quick dimensioning table PN 6

### Heating pipe PN 6

Spread							Mass flow rate	Pipe type $\Delta p$ . v	Pipe type $\Delta p$ . v	Pipe type $\Delta p$ . v
$\Delta\theta = 10$ K	$\Delta\theta = 15$ K	$\Delta\theta = 20$ K	$\Delta\theta = 25$ K	$\Delta\theta = 30$ K	$\Delta\theta = 35$ K	$\Delta\theta = 40$ K				
10 kW	15 kW	<b>20 kW</b>	25 kW	30 kW	35 kW	40 kW	860 kg/h	25/20.4 0.3016 kPa/m 0.740 m/s	32/26.2 0.0909 kPa/m 0.449 m/s	40/32.6 0.0319 kPa/m 0.290 m/s
20 kW	30 kW	<b>40 kW</b>	50 kW	60 kW	70 kW	80 kW	1720 kg/h	32/26.2 0.3157 kPa/m 0.897 m/s	40/32.6 0.1106 kPa/m 0.579 m/s	50/40.8 0.0377 kPa/m 0.370 m/s
30 kW	45 kW	<b>60 kW</b>	75 kW	90 kW	105 kW	120 kW	2581 kg/h	32/26.2 0.6553 kPa/m 1.346 m/s	40/32.6 0.2294 kPa/m 0.869 m/s	50/40.8 0.0782 kPa/m 0.555 m/s
40 kW	60 kW	<b>80 kW</b>	100 kW	120 kW	140 kW	160 kW	3441 kg/h	40/32.6 0.3853 kPa/m 1.159 m/s	50/40.8 0.1312 kPa/m 0.740 m/s	63/51.4 0.0433 kPa/m 0.466 m/s
50 kW	75 kW	<b>100 kW</b>	125 kW	150 kW	175 kW	200 kW	4301 kg/h	50/40.8 0.1961 kPa/m 0.925 m/s	63/51.4 0.0647 kPa/m 0.583 m/s	75/61.4 0.0276 kPa/m 0.408 m/s
60 kW	90 kW	<b>120 kW</b>	150 kW	180 kW	210 kW	240 kW	5161 kg/h	50/40.8 0.2725 kPa/m 1.110 m/s	63/51.4 0.0899 kPa/m 0.699 m/s	75/61.4 0.0383 kPa/m 0.490 m/s
70 kW	105 kW	<b>140 kW</b>	175 kW	210 kW	245 kW	280 kW	6022 kg/h	50/40.8 0.3599 kPa/m 1.295 m/s	63/51.4 0.1186 kPa/m 0.816 m/s	75/61.4 0.0505 kPa/m 0.572 m/s
80 kW	120 kW	<b>160 kW</b>	200 kW	240 kW	280 kW	320 kW	6882 kg/h	63/51.4 0.1510 kPa/m 0.932 m/s	75/61.4 0.0643 kPa/m 0.653 m/s	90/73.6 0.0269 kPa/m 0.455 m/s
90 kW	135 kW	<b>180 kW</b>	225 kW	270 kW	315 kW	360 kW	7742 kg/h	63/51.4 0.1867 kPa/m 1.049 m/s	75/61.4 0.0795 kPa/m 0.735 m/s	90/73.6 0.0333 kPa/m 0.512 m/s
100 kW	150 kW	<b>200 kW</b>	250 kW	300 kW	350 kW	400 kW	8602 kg/h	63/51.4 0.2259 kPa/m 1.165 m/s	75/61.4 0.0961 kPa/m 0.817 m/s	90/73.6 0.0402 kPa/m 0.568 m/s
110 kW	165 kW	220 kW	275 kW	330 kW	385 kW	440 kW	9.462 kg/h	63/51.4 0.2684 kPa/m 1.282 m/s	75/61.4 0.1142 kPa/m 0.898 m/s	90/73.6 0.0478 kPa/m 0.625 m/s
120 kW	180 kW	<b>240 kW</b>	300 kW	360 kW	420 kW	480 kW	10323 kg/h	75/61.4 0.1336 kPa/m 0.980 m/s	90/73.6 0.0559 kPa/m 0.682 m/s	110/90.0 0.0213 kPa/m 0.456 m/s
130 kW	195 kW	<b>260 kW</b>	325 kW	390 kW	455 kW	520 kW	11183 kg/h	75/61.4 0.1544 kPa/m 1.062 m/s	90/73.6 0.0646 kPa/m 0.739 m/s	110/90.0 0.0246 kPa/m 0.494 m/s
140 kW	210 kW	<b>280 kW</b>	350 kW	420 kW	490 kW	560 kW	12043 kg/h	75/61.4 0.1766 kPa/m 1.143 m/s	90/73.6 0.0739 kPa/m 0.796 m/s	110/90.0 0.0281 kPa/m 0.532 m/s
150 kW	225 kW	<b>300 kW</b>	375 kW	450 kW	525 kW	600 kW	12903 kg/h	75/61.4 0.2000 kPa/m 1.225 m/s	90/73.6 0.0837 kPa/m 0.853 m/s	110/90.0 0.0318 kPa/m 0.570 m/s
160 kW	240 kW	<b>320 kW</b>	400 kW	480 kW	560 kW	640 kW	13763 kg/h	75/61.4 0.2248 kPa/m 1.307 m/s	90/73.6 0.0940 kPa/m 0.909 m/s	110/90.0 0.0358 kPa/m 0.608 m/s
170 kW	255 kW	<b>340 kW</b>	425 kW	510 kW	595 kW	680 kW	14624 kg/h	90/73.6 0.1049 kPa/m 0.966 m/s	110/90.0 0.0399 kPa/m 0.646 m/s	125/102 0.0217 kPa/m 0.501 m/s
180 kW	270 kW	<b>360 kW</b>	450 kW	540 kW	630 kW	720 kW	15484 kg/h	90/73.6 0.1164 kPa/m 1.023 m/s	110/90.0 0.0442 kPa/m 0.684 m/s	125/102 0.0240 kPa/m 0.531 m/s
190 kW	285 kW	<b>380 kW</b>	475 kW	570 kW	665 kW	760 kW	16344 kg/h	90/73.6 0.1283 kPa/m 1.080 m/s	110/90.0 0.0488 kPa/m 0.722 m/s	125/102 0.0265 kPa/m 0.560 m/s



## Heating pipe PN 6

Spread							Mass flow rate	Pipe type $\Delta p.v$	Pipe type $\Delta p. v$	Pipe type $\Delta p. v$
$\Delta\theta = 10\text{ K}$	$\Delta\theta = 15\text{ K}$	$\Delta\theta = 20\text{ K}$	$\Delta\theta = 25\text{ K}$	$\Delta\theta = 30\text{ K}$	$\Delta\theta = 35\text{ K}$	$\Delta\theta = 40\text{ K}$				
200 kW	300 kW	<b>400 kW</b>	500 kW	600 kW	700 kW	800 kW	17204 kg/h	90/73.6 0.1408 kPa/m 1.137 m/s	110/90 0.0535 kPa/m 0.760 m/s	125/102 0.0290 kPa/m 0.590 m/s
210 kW	315 kW	<b>420 kW</b>	525 kW	630 kW	735 kW	840 kW	18065 kg/h	90/73.6 0.1538 kPa/m 1.194 m/s	110/90 0.0584 kPa/m 0.798 m/s	125/102 0.0317 kPa/m 0.619 m/s
220 kW	330 kW	<b>440 kW</b>	550 kW	660 kW	770 kW	880 kW	18925 kg/h	90/73.6 0.1673 kPa/m 1.251 m/s	110/90 0.0636 kPa/m 0.836 m/s	125/102 0.0345 kPa/m 0.649 m/s
230 kW	345 kW	<b>460 kW</b>	575 kW	690 kW	805 kW	920 kW	19785 kg/h	90/73.6 0.1813 kPa/m 1.307 m/s	110/90 0.0689 kPa/m 0.874 m/s	125/102 0.0374 kPa/m 0.678 m/s
240 kW	360 kW	<b>480 kW</b>	600 kW	720 kW	840 kW	960 kW	20640 kg/h	110/90 0.0744 kPa/m 0.912 m/s	125/102 0.0404 kPa/m 0.708 m/s	
250 kW	375 kW	<b>500 kW</b>	625 kW	750 kW	875 kW	1000 kW	21505 kg/h	110/90 0.0801 kPa/m 0.950 m/s	125/102 0.0435 kPa/m 0.737 m/s	
260 kW	390 kW	<b>520 kW</b>	650 kW	780 kW	910 kW	1040 kW	22366 kg/h	110/90 0.0860 kPa/m 0.988 m/s	125/102 0.0467 kPa/m 0.766 m/s	
270 kW	405 kW	<b>540 kW</b>	675 kW	810 kW	945 kW	1080 kW	23220 kg/h	110/90 0.0921 kPa/m 1.026 m/s	125/102 0.0500 kPa/m 0.796 m/s	
280 kW	420 kW	<b>560 kW</b>	700 kW	840 kW	980 kW	1120 kW	24086 kg/h	110/90 0.0984 kPa/m 1.064 m/s	125/102 0.0534 kPa/m 0.825 m/s	
290 kW	435 kW	<b>580 kW</b>	725 kW	870 kW	1015 kW	1160 kW	24946 kg/h	110/90 0.1048 kPa/m 1.102 m/s	125/102 0.0569 kPa/m 0.855 m/s	
300 kW	450 kW	<b>600 kW</b>	750 kW	900 kW	1050 kW	1200 kW	25806 kg/h	110/90 0.1115 kPa/m 1.140 m/s	125/102 0.0605 kPa/m 0.884 m/s	
310 kW	465 kW	<b>620 kW</b>	775 kW	930 kW	1085 kW	1240 kW	26667 kg/h	110/90 0.1183 kPa/m 1.178 m/s	125/102 0.0642 kPa/m 0.914 m/s	
320 kW	480 kW	<b>640 kW</b>	800 kW	960 kW	1120 kW	1280 kW	27527 kg/h	110/90 0.1253 kPa/m 1.216 m/s	125/102 0.0680 kPa/m 0.943 m/s	
330 kW	495 kW	<b>660 kW</b>	825 kW	990 kW	1155 kW	1320 kW	28387 kg/h	110/90 0.1325 kPa/m 1.254 m/s	125/102 0.0719 kPa/m 0.973 m/s	
340 kW	510 kW	<b>680 kW</b>	850 kW	1020 kW	1190 kW	1360 kW	29247 kg/h	110/90 0.1398 kPa/m 1.292 m/s	125/102 0.0759 kPa/m 1.002 m/s	
350 kW	525 kW	<b>700 kW</b>	875 kW	1050 kW	1225 kW	1400 kW	30108 kg/h	125/102 0.0799 kPa/m 1.032 m/s		
360 kW	540 kW	<b>720 kW</b>	900 kW	1080 kW	1260 kW	1440 kW	30968 kg/h	125/102 0.0841 kPa/m 1.061 m/s		
370 kW	555 kW	<b>740 kW</b>	925 kW	1110 kW	1295 kW	1480 kW	31828 kg/h	125/102 0.0884 kPa/m 1.091 m/s		
380 kW	570 kW	<b>760 kW</b>	950 kW	1140 kW	1330 kW	1520 kW	32688 kg/h	125/102 0.0928 kPa/m 1.120 m/s		

## Heating pipe PN 6

Spread							Mass flow rate	Pipe type $\Delta p \cdot v$	Pipe type $\Delta p \cdot v$	Pipe type $\Delta p \cdot v$
$\Delta\theta = 10 \text{ K}$	$\Delta\theta = 15 \text{ K}$	$\Delta\theta = 20 \text{ K}$	$\Delta\theta = 25 \text{ K}$	$\Delta\theta = 30 \text{ K}$	$\Delta\theta = 35 \text{ K}$	$\Delta\theta = 40 \text{ K}$				
390 kW	585 kW	<b>780 kW</b>	975 kW	1170 kW	1365 kW	1560 kW	33548 kg/h	125/102 0.0973 kPa/m 1.150 m/s		
400 kW	600 kW	<b>800 kW</b>	1000 kW	1200 kW	1400 kW	1600 kW	34409 kg/h	125/102 0.1018 kPa/m 1.179 m/s		
410 kW	615 kW	<b>820 kW</b>	1025 kW	1230 kW	1435 kW	1640 kW	35269 kg/h	125/102 0.1065 kPa/m 1.209 m/s		
420 kW	630 kW	<b>840 kW</b>	1050 kW	1260 kW	1470 kW	1680 kW	36129 kg/h	125/102 0.1112 kPa/m 1.238 m/s		
430 kW	645 kW	<b>860 kW</b>	1075 kW	1290 kW	1505 kW	1720 kW	36989 kg/h	125/102 0.1161 kPa/m 1.268 m/s		
440 kW	660 kW	<b>880 kW</b>	1100 kW	1320 kW	1540 kW	1760 kW	37849 kg/h	125/102 0.1210 kPa/m 1.297 m/s		
450 kW	675 kW	<b>900 kW</b>	1125 kW	1350 kW	1575 kW	1800 kW	38710 kg/h	125/102 0.1261 kPa/m 1.327 m/s		

## Quick dimensioning table PN 10

### Heating pipe PN 10

Spread							Mass flow rate	Pipe type $\Delta p$ , v	Pipe type $\Delta p$ , v	Pipe type $\Delta p$ , v
$\Delta\theta = 10$ K	$\Delta\theta = 15$ K	$\Delta\theta = 20$ K	$\Delta\theta = 25$ K	$\Delta\theta = 30$ K	$\Delta\theta = 35$ K	$\Delta\theta = 40$ K				
10 kW	15 kW	<b>20 kW</b>	25 kW	30 kW	35 kW	40 kW	860 kg/h	25/18 0.5498 kPa/m 0.950 m/s	32/23.2 0.1628 kPa/m 0.572 m/s	40/29 0.0558 kPa/m 0.366 m/s
20 kW	30 kW	<b>40 kW</b>	50 kW	60 kW	70 kW	80 kW	1720 kg/h	32/23.2 0.5660 kPa/m 1.144 m/s	40/29 0.1939 kPa/m 0.732 m/s	50/36.2 0.0669 kPa/m 0.470 m/s
30 kW	45 kW	<b>60 kW</b>	75 kW	90 kW	105 kW	120 kW	2581 kg/h	40/29 0.4024 kPa/m 1.098 m/s	50/36.2 0.1388 kPa/m 0.705 m/s	63/45.8 0.0449 kPa/m 0.440 m/s
40 kW	60 kW	<b>80 kW</b>	100 kW	120 kW	140 kW	160 kW	3441 kg/h	50/36.2 0.2330 kPa/m 0.940 m/s	63/45.8 0.0753 kPa/m 0.587 m/s	75/54.4 0.0330 kPa/m 0.416 m/s
50 kW	75 kW	<b>100 kW</b>	125 kW	150 kW	175 kW	200 kW	4301 kg/h	50/36.2 0.3484 kPa/m 1.175 m/s	63/45.8 0.1126 kPa/m 0.734 m/s	75/54.4 0.0493 kPa/m 0.520 m/s
60 kW	90 kW	<b>120 kW</b>	150 kW	180 kW	210 kW	240 kW	5161 kg/h	63/45.8 0.1564 kPa/m 0.881 m/s	75/54.4 0.0684 kPa/m 0.624 m/s	90/65.4 0.0283 kPa/m 0.432 m/s
70 kW	105 kW	<b>140 kW</b>	175 kW	210 kW	245 kW	280 kW	6022 kg/h	63/45.8 0.2065 kPa/m 1.028 m/s	75/54.4 0.0903 kPa/m 0.728 m/s	90/65.4 0.0373 kPa/m 0.504 m/s
80 kW	120 kW	<b>160 kW</b>	200 kW	240 kW	280 kW	320 kW	6882 kg/h	63/45.8 0.2628 kPa/m 1.174 m/s	75/54.4 0.1150 kPa/m 0.832 m/s	90/65.4 0.0475 kPa/m 0.576 m/s
90 kW	135 kW	<b>180 kW</b>	225 kW	270 kW	315 kW	360 kW	7742 kg/h	63/45.8 0.3251 kPa/m 1.321 m/s	75/54.4 0.1422 kPa/m 0.936 m/s	90/65.4 0.0587 kPa/m 0.648 m/s
100 kW	150 kW	<b>200 kW</b>	250 kW	300 kW	350 kW	400 kW	8602 kg/h	75/54.4 0.1720 kPa/m 1.040 m/s	90/65.4 0.0710 kPa/m 0.720 m/s	110/79.8 0.0273 kPa/m 0.484 m/s
110 kW	165 kW	<b>220 kW</b>	275 kW	330 kW	385 kW	440 kW	9.462 kg/h	75/54.4 0.2043 kPa/m 1.145 m/s	90/65.4 0.0843 kPa/m 0.792 m/s	110/79.8 0.0324 kPa/m 0.532 m/s
120 kW	180 kW	<b>240 kW</b>	300 kW	360 kW	420 kW	480 kW	10323 kg/h	75/54.4 0.2391 kPa/m 1.249 m/s	90/65.4 0.0987 kPa/m 0.864 m/s	110/79.8 0.0379 kPa/m 0.580 m/s
130 kW	195 kW	<b>260 kW</b>	325 kW	390 kW	455 kW	520 kW	11183 kg/h	75/54.4 0.2763 kPa/m 1.353 m/s	90/65.4 0.1140 kPa/m 0.936 m/s	110/79.8 0.0438 kPa/m 0.629 m/s
140 kW	210 kW	<b>280 kW</b>	350 kW	420 kW	490 kW	560 kW	12043 kg/h	90/65.4 0.1303 kPa/m 1.008 m/s	110/79.8 0.0501 kPa/m 0.677 m/s	
150 kW	225 kW	<b>300 kW</b>	375 kW	450 kW	525 kW	600 kW	12903 kg/h	90/65.4 0.1477 kPa/m 1.080 m/s	110/79.8 0.0567 kPa/m 0.725 m/s	
160 kW	240 kW	<b>320 kW</b>	400 kW	480 kW	560 kW	640 kW	13763 kg/h	90/65.4 0.1659 kPa/m 1.152 m/s	110/79.8 0.0637 kPa/m 0.774 m/s	
170 kW	255 kW	<b>340 kW</b>	425 kW	510 kW	595 kW	680 kW	14624 kg/h	90/65.4 0.1852 kPa/m 1.224 m/s	110/79.8 0.0711 kPa/m 0.822 m/s	
180 kW	270 kW	<b>360 kW</b>	450 kW	540 kW	630 kW	720 kW	15484 kg/h	90/65.4 0.2054 kPa/m 1.296 m/s	110/79.8 0.0789 kPa/m 0.870 m/s	
190 kW	285 kW	<b>380 kW</b>	475 kW	570 kW	665 kW	760 kW	16344 kg/h	110/79.8 0.0870 kPa/m 0.919 m/s		

## Heating pipe PN 10

Spread							Mass flow rate	Pipe type $\Delta p.v$
$\Delta\theta = 10\text{ K}$	$\Delta\theta = 15\text{ K}$	$\Delta\theta = 20\text{ K}$	$\Delta\theta = 25\text{ K}$	$\Delta\theta = 30\text{ K}$	$\Delta\theta = 35\text{ K}$	$\Delta\theta = 40\text{ K}$		
200 kW	300 kW	<b>400 kW</b>	500 kW	600 kW	700 kW	800 kW	17204 kg/h	110/79.8 0.0954 kPa/m 0.967 m/s
210 kW	315 kW	<b>420 kW</b>	525 kW	630 kW	735 kW	840 kW	18065 kg/h	110/79.8 0.1042 kPa/m 1.015 m/s
220 kW	330 kW	<b>440 kW</b>	550 kW	660 kW	770 kW	880 kW	18925 kg/h	110/79.8 0.1134 kPa/m 1.064 m/s
230 kW	345 kW	<b>460 kW</b>	575 kW	690 kW	805 kW	920 kW	19785 kg/h	110/79.8 0.1229 kPa/m 1.112 m/s
240 kW	360 kW	<b>480 kW</b>	600 kW	720 kW	840 kW	960 kW	20640 kg/h	110/79.8 0.1327 kPa/m 1.160 m/s
250 kW	375 kW	<b>500 kW</b>	625 kW	750 kW	875 kW	1000 kW	21505 kg/h	110/79.8 0.1429 kPa/m 1.209 m/s
260 kW	390 kW	<b>520 kW</b>	650 kW	780 kW	910 kW	1040 kW	22366 kg/h	110/79.8 0.1534 kPa/m 1.257 m/s
270 kW	405 kW	<b>540 kW</b>	675 kW	810 kW	945 kW	1080 kW	23220 kg/h	110/79.8 0.1643 kPa/m 1.306 m/s



## Heat loss

### Heat loss Uponor Ecoflex Thermo Single PN 6 and PN 10

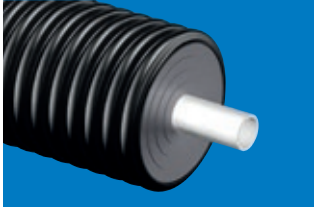

Thermal conductivity of the ground:	1.0 W/mK
Ground cover:	0.8 m
$\lambda$ PE-Xa pipe:	0,035 W/mK
$\lambda$ Insulation material:	0,040 W/mK at 40 °C

#### NOTE!

Heat loss data in the diagram are calculated with a safety factor of 1.05, according to the requirements of the German "VDI-AG Gütesicherung". Depending on production related tolerances.

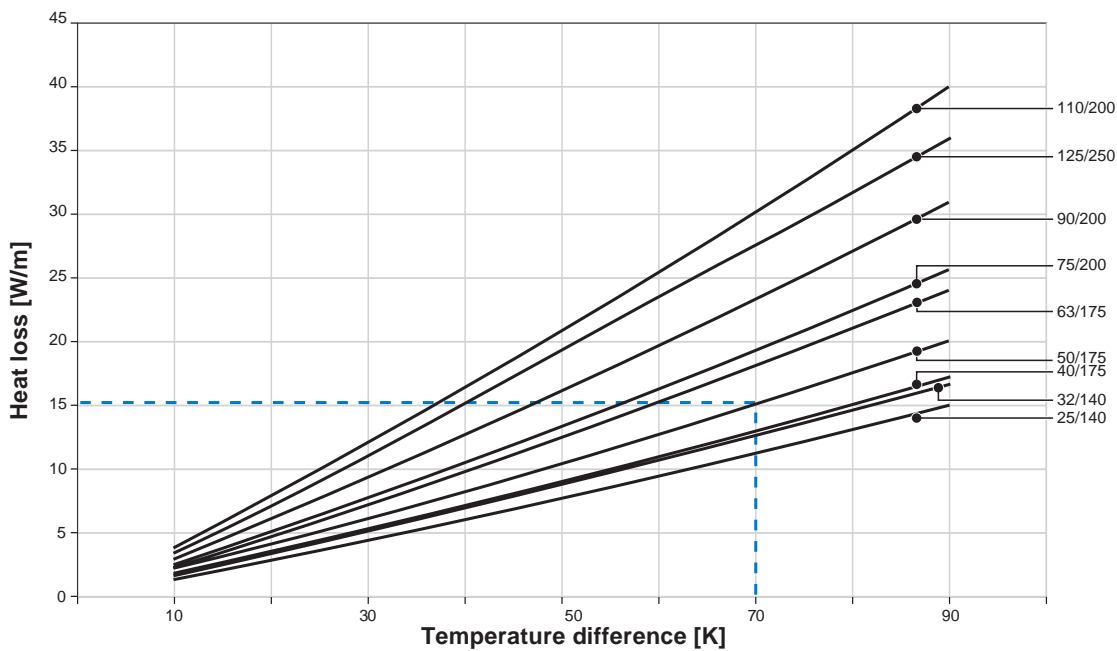

#### Example for Thermo Single 50/175

$\theta_M$  = Temperature of medium  
 $\theta_E$  = Temperature of the ground  
 $\Delta\theta$  = Temperature difference (K)

$\Delta\theta = \theta_M - \theta_E$   
 $\theta_M = 75\text{ °C}$   
 $\theta_E = 5\text{ °C}$   
 $\Delta\theta = 75 - 5 = 70\text{ K}$   
**Heat loss: 15.1 W/m**



Monitored according to VDI 2055

#### NOTE!

Heat loss of Thermo PN 6 pipes are monitored and certificated.

#### NOTE!

The diagram shows the heat loss of one pipe. To get the total heat loss add the flow and return heat losses, the heat loss of flow and return has to be calculated separately.

## Heat loss Uponor Ecoflex Thermo Twin PN 6 and PN 10

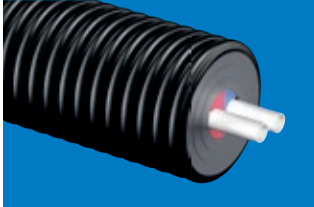

Thermal conductivity of the ground:	1.0 W/mK
Ground cover:	0.8 m
$\lambda$ PE-Xa pipe:	0,035 W/mK
$\lambda$ Insulation material:	0,040 W/mK at 40 °C

### NOTE!

Heat loss data in the diagram are calculated with a safety factor of 1.05, according to the requirements of the German "VDI-AG Gütesicherung". Depending on production related tolerances.

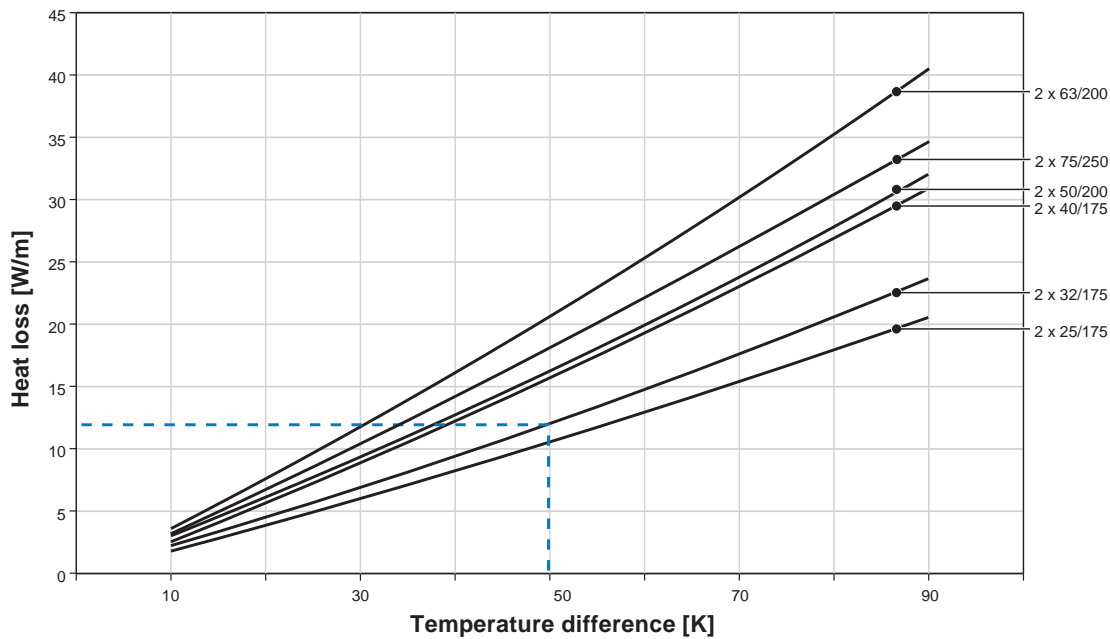

### Example for Thermo Twin 2 x 32/175

$\theta_V$  = Flow temperature  
 $\theta_R$  = Return temperature  
 $\theta_E$  = Temperature of the ground  
 $\Delta\theta$  = Temperature difference (K)  
 $\Delta\theta = (\theta_V + \theta_R) / 2 - \theta_E$   
 $\theta_V = 70 \text{ °C}$   
 $\theta_R = 40 \text{ °C}$   
 $\theta_E = 5 \text{ °C}$   
 $\Delta\theta = (70 + 40) / 2 - 5 = 50 \text{ K}$

**Heat loss: 12 W/m**



Monitored according to VDI 2055

## Heat loss Uponor Ecoflex Thermo Mini PN 6

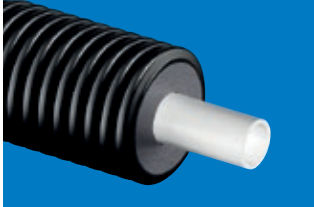

Thermal conductivity of the ground:	1.0 W/mK
Ground cover:	0.8 m
$\lambda$ PE-Xa pipe:	0,035 W/mK
$\lambda$ Insulation material:	0,040 W/mK at 40 °C

### NOTE!

Heat loss data in the diagram are calculated with a safety factor of 1.05, according to the requirements of the German "VDI-AG Gütesicherung". Depending on production related tolerances.

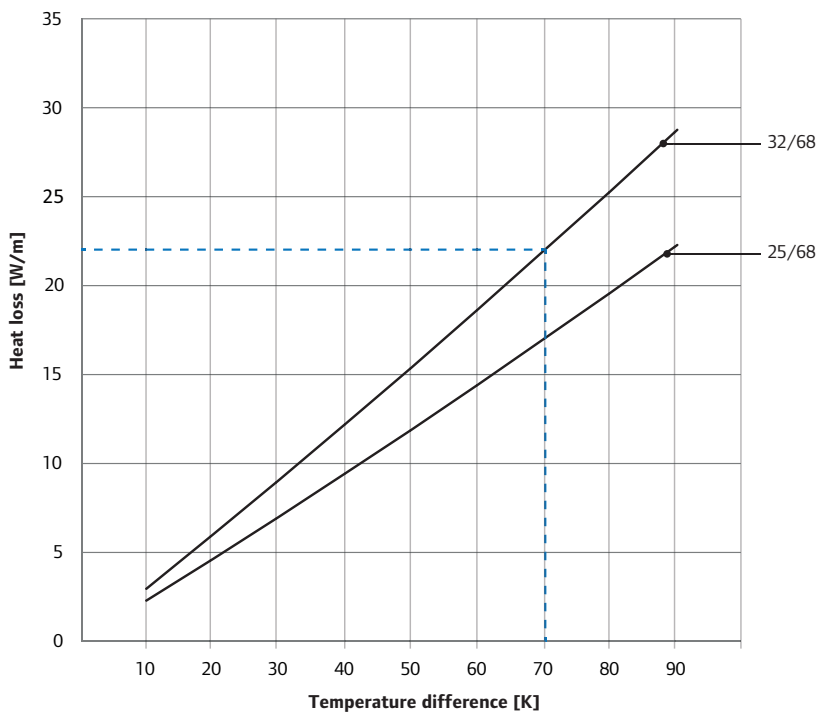

### Example for Thermo Mini 32/68

$\theta_M$  = Temperature of medium  
 $\theta_E$  = Temperature of the ground  
 $\Delta\theta$  = Temperature difference (K)

$\Delta\theta = \theta_M - \theta_E$   
 $\theta_M = 75\text{ °C}$   
 $\theta_E = 5\text{ °C}$   
 $\Delta\theta = 75 - 5 = 70\text{ K}$

**Heat loss: 22 W/m**

### NOTE!

The diagram shows the heat loss of one pipe. To get the total heat loss add the flow and return heat losses, the heat loss of flow and return has to be calculated separately.

## Heat loss Uponor Ecoflex Thermo PRO Single PN 6

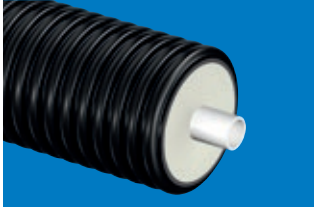

Thermal conductivity of the ground: 1.0 W/mK  
 Ground cover: 0.8 m  
 $\lambda$  PE-Xa pipe: 0,035 W/mK  
 $\lambda$  Insulation material: 0,0219W/mK at 50 °C

Please contact Uponor sales office for installation specific heat loss calculation.

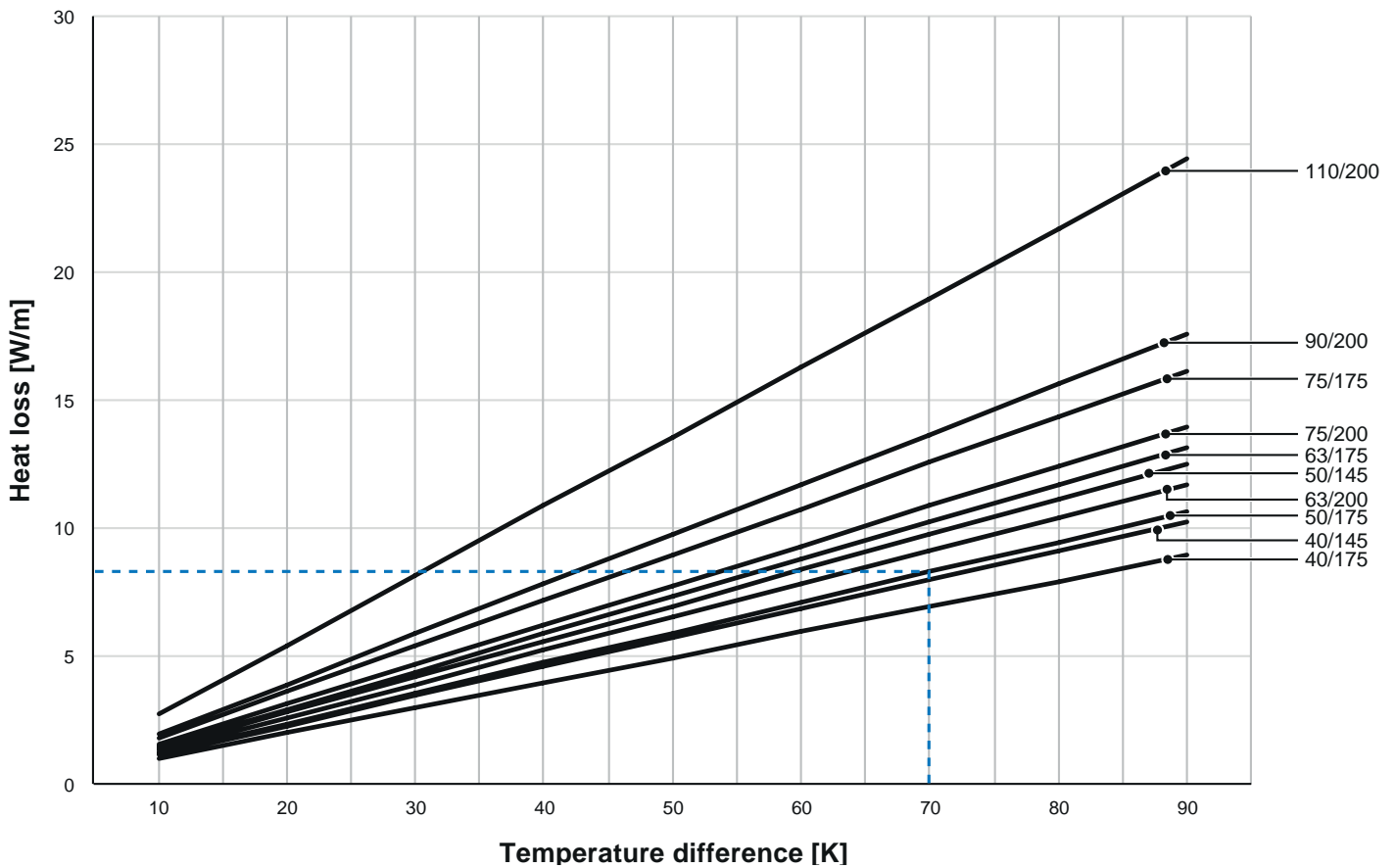

### Example for Thermo PRO Single 50/175

$\theta_M$  = Temperature of medium  
 $\theta_E$  = Temperature of the ground  
 $\Delta\theta$  = Temperature difference (K)

$\Delta\theta = \theta_M - \theta_E$   
 $\theta_M = 75\text{ °C}$   
 $\theta_E = 5\text{ °C}$   
 $\Delta\theta = 75 - 5 = 70\text{ K}$   
**Heat loss: 8.3 W/m**

#### NOTE!

The diagram shows the heat loss of one pipe. To get the total heat loss add the flow and return heat losses, the heat loss of flow and return has to be calculated separately.

## Heat loss Uponor Ecoflex Thermo PRO Twin PN 6

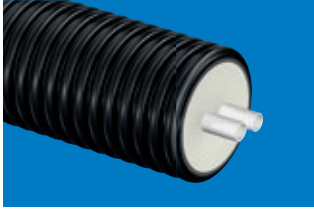

**Thermal conductivity of the ground:** 1.0 W/mK  
**Ground cover:** 0.8 m  
**λ PE-Xa pipe:** 0,035 W/mK  
**λ Insulation material:** 0,0219W/mK at 50 °C

Please contact Uponor sales office for installation specific heat loss calculation.

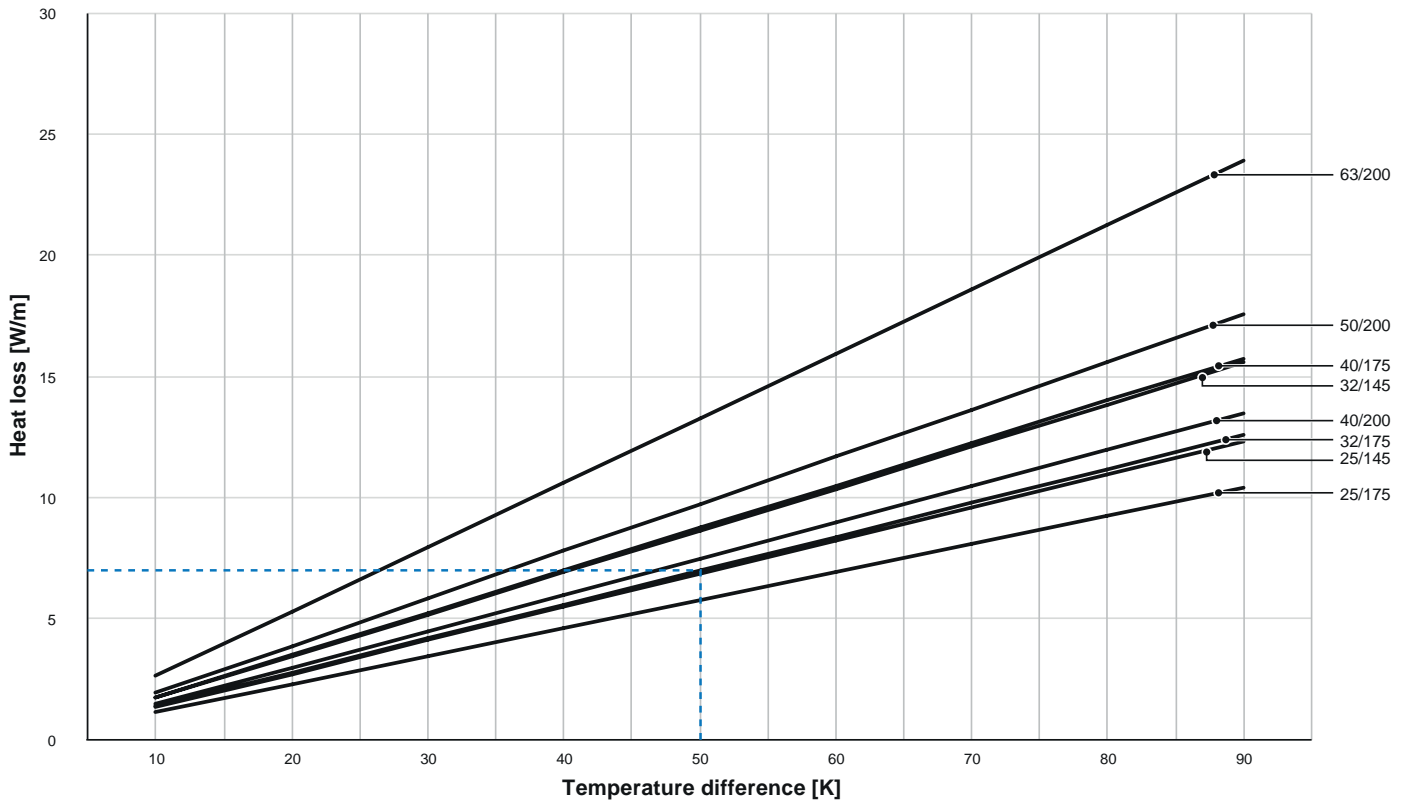

### Example for Thermo PRO Twin 2 x 32/175

$\theta_V$  = Flow temperature  
 $\theta_R$  = Return temperature  
 $\theta_E$  = Temperature of the ground  
 $\Delta\theta$  = Temperature difference (K)  
 $\Delta\theta = (\theta_V + \theta_R) / 2 - \theta_E$   
 $\theta_V = 70 \text{ }^\circ\text{C}$   
 $\theta_R = 40 \text{ }^\circ\text{C}$   
 $\theta_E = 5 \text{ }^\circ\text{C}$   
 $\Delta\theta = (70 + 40) / 2 - 5 = 50 \text{ K}$

**Heat loss: 7.0 W/m**



## Heat loss Uponor Ecoflex Varia Single PN 6 and PN 10

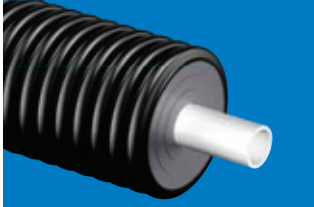

**Thermal conductivity of the ground:** 1.0 W/mK  
**Ground cover:** 0.8 m  
**λ PE-Xa pipe:** 0,035 W/mK  
**λ Insulation material:** 0,040 W/mK at 40 °C

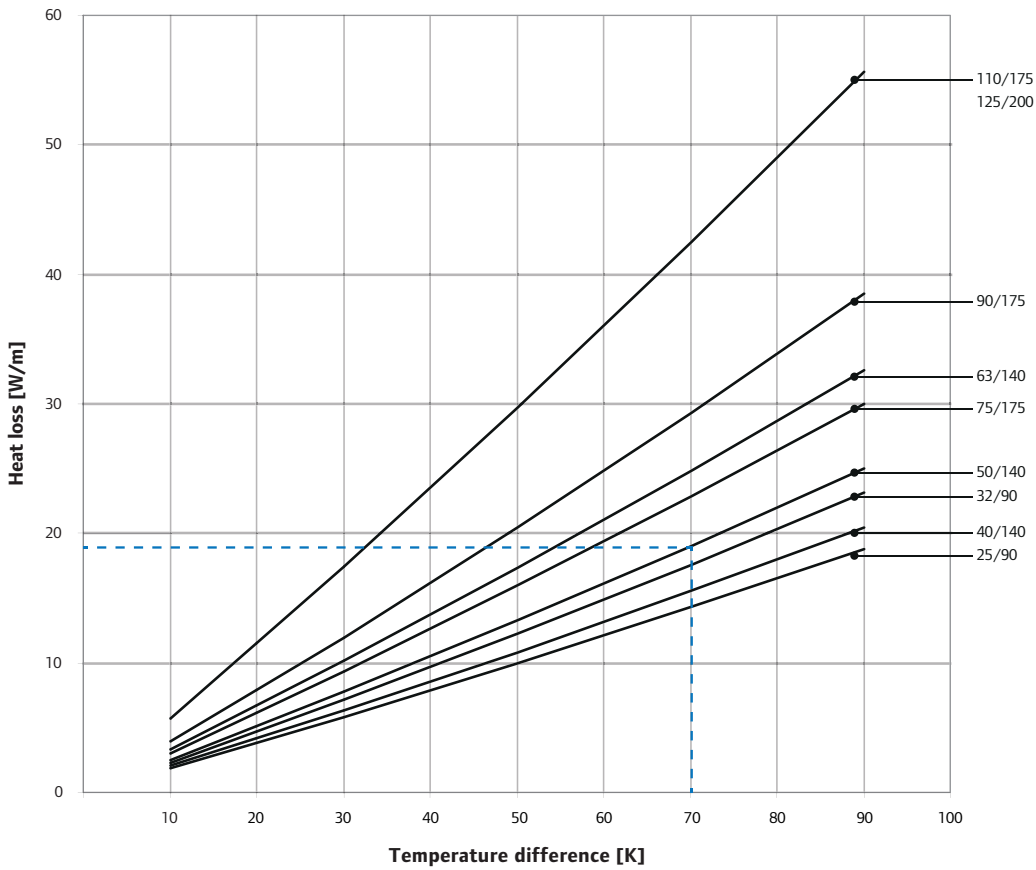

### Example for Varia Single 50/140

$\theta_M$  = Temperature of medium  
 $\theta_E$  = Temperature of the ground  
 $\Delta\theta$  = Temperature difference (K)

$\Delta\theta = (\theta_M - \theta_E) / 2 - \theta_E$   
 $\theta_M = 75\text{ °C}$   
 $\theta_E = 5\text{ °C}$   
 $\Delta\theta = 75 - 5 = 70\text{ K}$   
**Heat loss: 18.5 W/m**

#### NOTE!

The diagram shows the heat loss of one pipe. To get the total heat loss add the flow and return heat losses, the heat loss of flow and return has to be calculated separately.

## Heat loss Uponor Ecoflex Varia Twin PN 6 and PN 10

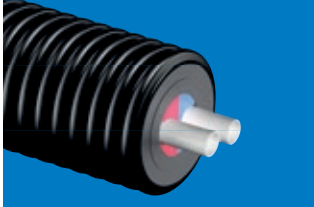

Thermal conductivity of the ground: 1.0 W/mK  
 Ground cover: 0.8 m  
 $\lambda$  PE-Xa pipe: 0,035 W/mK  
 $\lambda$  Insulation material: 0,040 W/mK at 40 °C

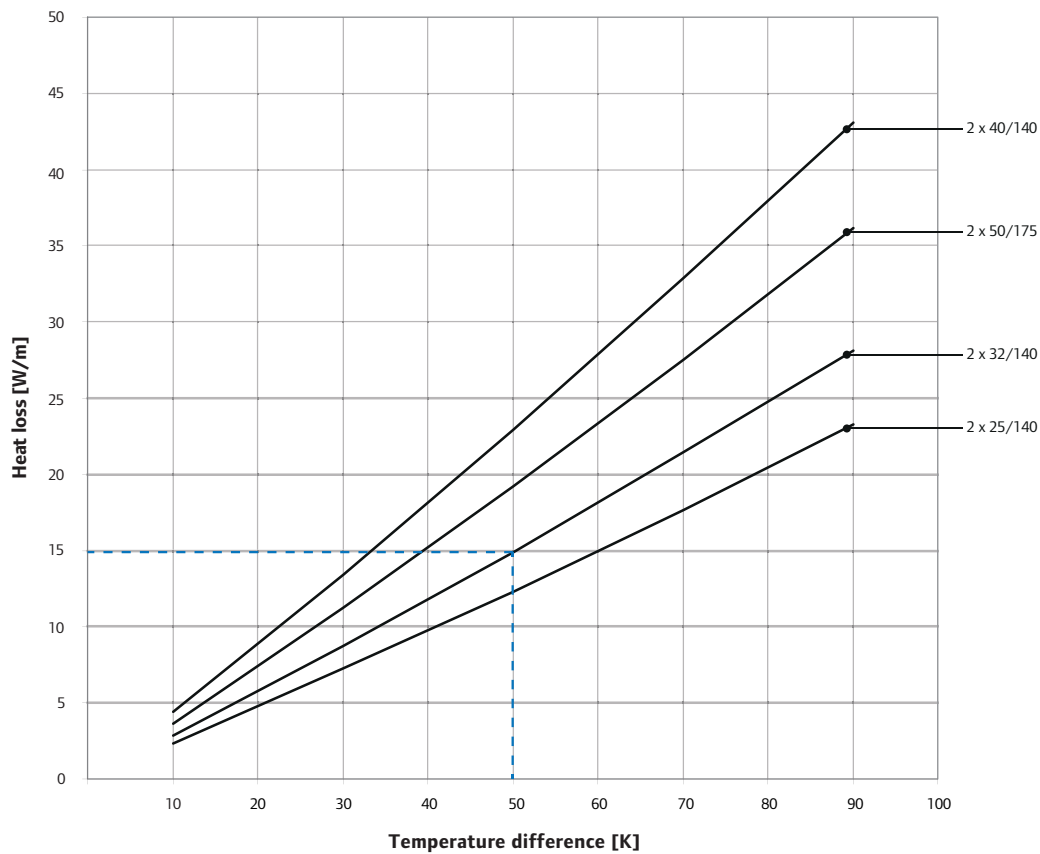

### Example for Varia Twin 2 x 32/140

$\theta_V$  = Flow temperature

$\theta_R$  = Return temperature

$\theta_E$  = Temperature of the ground

$\Delta\theta$  = Temperature difference (K)

$\Delta\theta = (\theta_V - \theta_R) / 2 - \theta_E$

$\theta_V = 70$  °C

$\theta_R = 40$  °C

$\theta_E = 5$  °C

$\Delta\theta = (70 - 40) / 2 - 5 = 50$  K

**Heat loss: 15 W/m**

## Heat loss Uponor Aqua Single

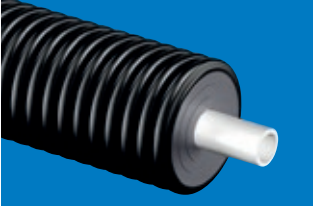

Thermal conductivity of the ground: 1.0 W/mK  
 Ground cover: 0.8 m  
 PE-Xa pipe: 0.035 W/mK  
 Insulation material: 0.040 W/mK at 40 °C

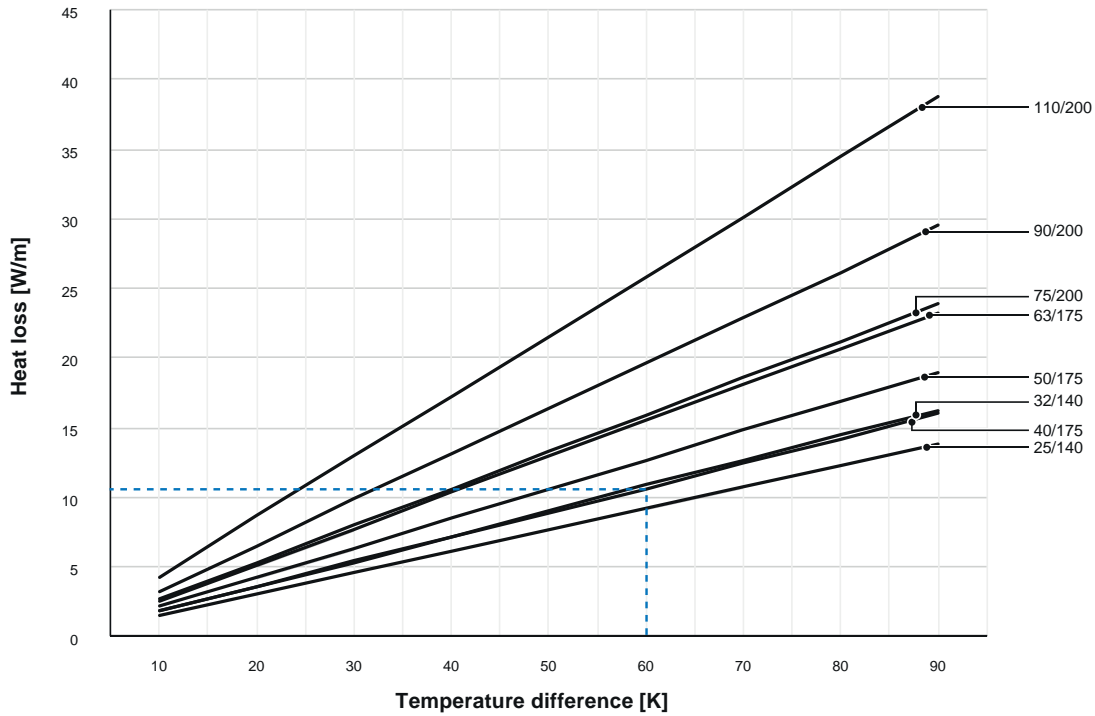

### Example for Aqua Single 40/175

$\theta_M$  = Temperature of medium  
 $\theta_E$  = Temperature of the ground  
 $\Delta\theta$  = Temperature difference (K)

$$\Delta\theta = \theta_M + \theta_E$$

$$\theta_M = 65 \text{ }^\circ\text{C}$$

$$\theta_E = 5 \text{ }^\circ\text{C}$$

$$\Delta\theta = 65 - 5 = 60 \text{ K}$$

**Heat loss: 10.5 W/m**

## Heat loss Uponor Aqua Twin

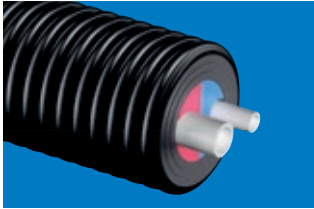

Thermal conductivity of the ground:	1.0 W/mK
Ground cover:	0.8 m
PE-Xa pipe:	0.035 W/mK
Insulation material:	0.040 W/mK at 40 °C

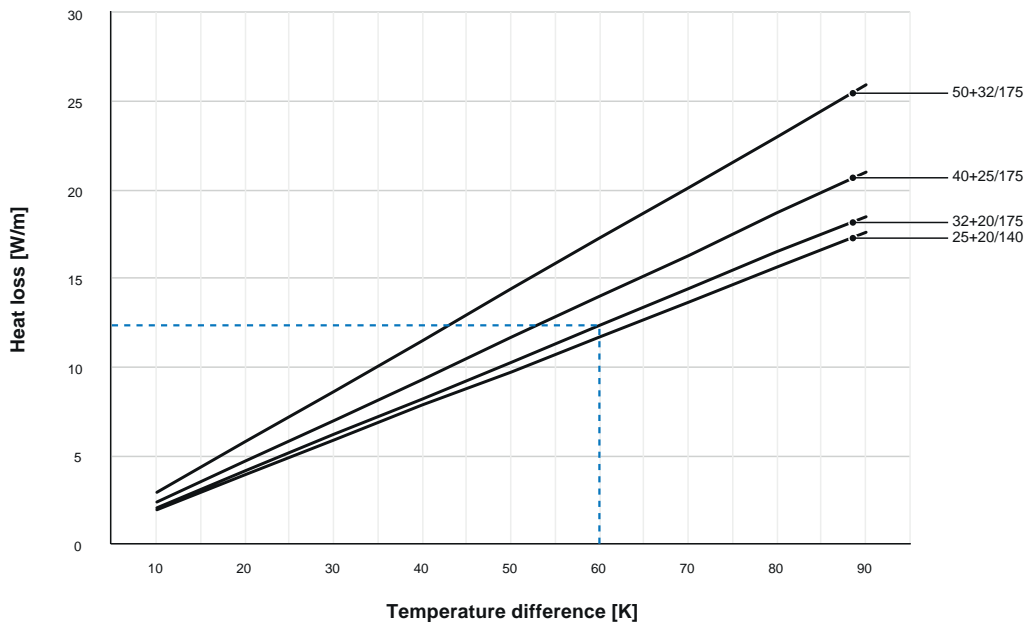

### Example for Aqua Twin 32+20/175

$\theta_V$  = Flow temperature  
 $\theta_R$  = Return temperature  
 $\theta_E$  = Temperature of the ground  
 $\Delta\theta$  = Temperature difference (K)

$$\Delta\theta = (\theta_V + \theta_R) / 2 - \theta_E$$

$\theta_V = 65\text{ °C}$   
 $\theta_R = 55\text{ °C}$   
 $\theta_E = 0\text{ °C}$   
 $\Delta\theta = (65 + 55) / 2 - 0 = 60\text{ K}$

**Heat loss: 12 W/m**

## Heat loss Uponor Ecoflex Quattro

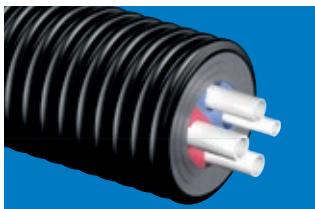

Thermal conductivity of the ground:	1.0 W/mK
Ground cover:	0.8 m
PE-Xa pipe:	0.035 W/mK
Insulation material:	0.040 W/mK at 40 °C

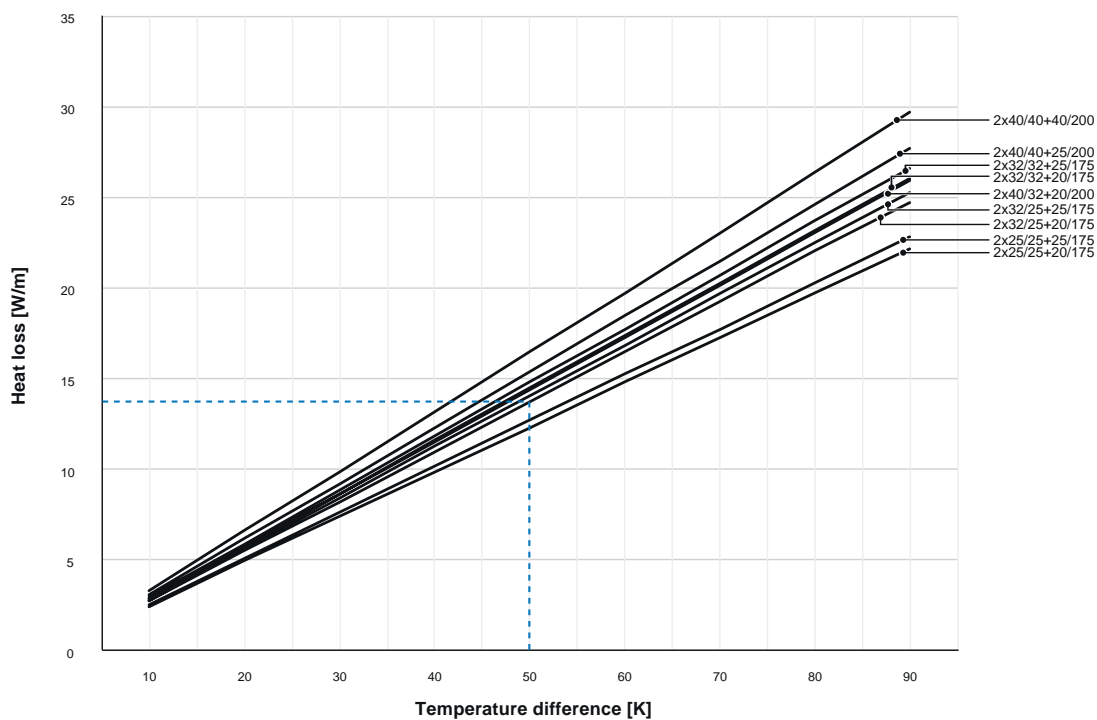

### Example for Quattro 2 x 32 - 25 + 20/175

$t_1$  = Temperature Heating flow

$t_2$  = Temperature Heating return

$t_3$  = Temperature Warm water flow

$t_4$  = Temperature Warm water return

$t_E$  = Temperature of the ground

$\Delta t = (t_1 + t_2 + t_3 + t_4) / 4 - t_E$

$t_1 = 60 \text{ }^\circ\text{C}$

$t_2 = 40 \text{ }^\circ\text{C}$

$t_3 = 65 \text{ }^\circ\text{C}$

$t_4 = 55 \text{ }^\circ\text{C}$

$t_E = 5 \text{ }^\circ\text{C}$

$\Delta t = (60 + 40 + 65 + 55) / 4 - 5 = 50$

**Heat loss: 13.7 W/m**





# Installation



# Installation

## Guideline values for the installation process



The time required to lay these pipe systems depends on local conditions. In the following table, obstacles, underpasses, weather conditions, fitting times and other aspects have not been taken into account. The use of aids such as excavators or cable winches has also not been included in the calculation.

### Installation time for Thermo products

Pipe type	25 meters Fitters/min.	50 meters Fitters/min.	100 meters Fitters/min.
<b>Single:</b>			
25	2 / 15	2 / 30	3 / 40
32	2 / 15	2 / 30	3 / 40
40	2 / 20	2 / 40	3 / 60
50	2 / 20	2 / 40	3 / 60
63	3 / 20	3 / 40	4 / 60
75	3 / 25	3 / 50	4 / 75
90	3 / 30	4 / 60	5 / 90
110	3 / 30	4 / 60	5 / 90
125	4 / 30	5 / 60	6 / 90
<b>Twin:</b>			
25	2 / 20	2 / 40	3 / 60
32	2 / 20	2 / 40	3 / 60
40	2 / 30	3 / 40	4 / 60
50	3 / 25	3 / 50	5 / 90
63	3 / 30	4 / 60	5 / 90
75	3 / 40	4 / 70	5 / 100
<b>Quattro:</b>			
25	2 / 20	2 / 40	3 / 60
32	2 / 30	3 / 40	4 / 60
40	3 / 25	3 / 50	4 / 80

### Guideline values for average fitting time for jointing equipment and accessories:

Number of fitters / group minutes per item (e.g. 2/15 = 2 fitters require 15 minutes per item)	
Rubber end caps	1 / 5
Wipex coupling	1 / 15
Wipex straight joint	2 / 30
Wipex tee (complete)	2 / 40
Straight insulation set	1 / 35
T-insulation set	1 / 45
Elbow insulation set	1 / 35
Double tee set	2 / 50
Chamber incl. 6 x connections to the jacket pipe	2 / 50
Wall sleeve set NPW (non pressure waterproof)	1 / 30
Wall seal PWP (pressure waterproof)	1 / 30

### Two examples of the average fitting time for Uponor pipes:

#### Example 1:

- Installation of 2 x 25 m Uponor Ecoflex Thermo Single 63 mm
- 3 fitters with no additional aids

**Installation time: 2 x 20 minutes**

#### Example 2:

- Installation of a wall sleeve set NPW
- 1 fitter with no additional aids
- Guide figure for rubber end cap 1/5, Wipex coupling 1/15, wall sleeve set NPW 1/30

**Installation time: 1 x 50 minutes**



The assembly times mentioned above are group minutes for the corresponding number of fitters (not including excavation work). The figures are only guidance for calculation.

## Pipe handling

### Storing, lifting and handling the pipe coil



Conical end caps have been mounted on the ends of the pipes to protect the flow pipes against sunlight and other damage, including soiling during transportation. Protect the pipe coil from sharp objects during transportation and storage.

Do not drag the coil across rough surfaces. Ensure that the coil is not squashed and that the pipe is not dented when bent during storage. Store all coils in a horizontal position. Pipe coils and chambers can be stored outside, other components of the system should be stored indoors.

When unloading, do not drop the coils. Do not transport a pipe coil by pulling it. Use belts for lifting the coil.

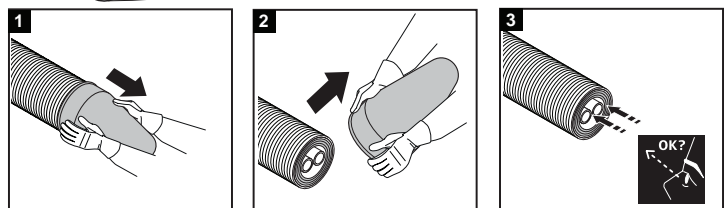
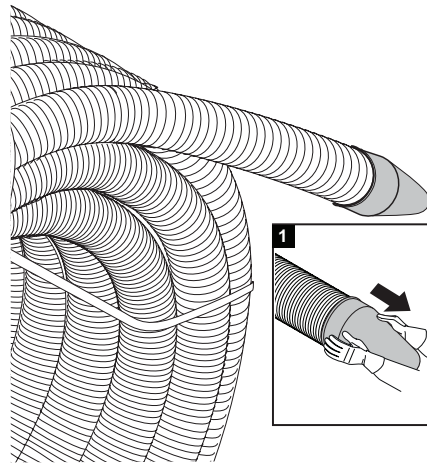
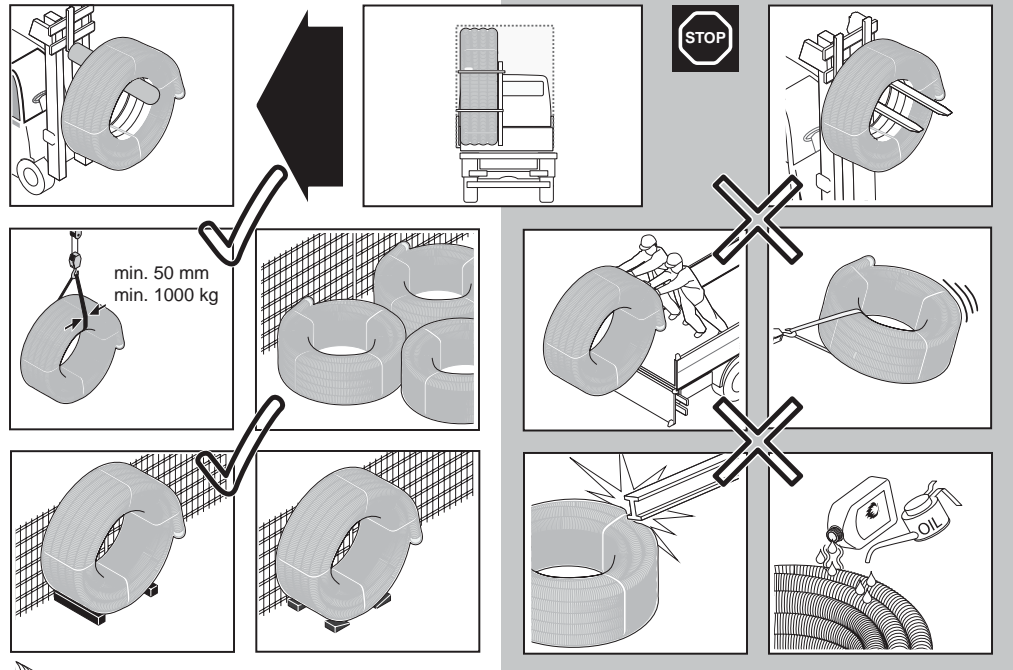

#### PLEASE NOTE!

When lifting pipe coils, use at least a 50 mm diameter nylon or textile loop. If fork truck or other similar lifting equipment is used, the forks must be rounded or padded. Due to the flexibility and weight of the coils, the diameter of the coils can vary by up to 30 cm.

#### PLEASE NOTE!

Plastic materials must never be brought into contact with aggressive substances such as motor fuel, solvents, timber preservative or similar.

## Uncoiling

Store the delivered coil as far as possible in its protective packaging until installation! Then uncoil the pipe directly into or beside the trench.

Never pull the pipe across the ground as pointed objects could cause damage. Should the jacket pipe become damaged, it can be repaired using a shrinkable sleeve.

All pipeline parts and system accessories must be visually inspected prior to installation or processing for damage of influences

which impact its function. Parts which are inacceptably impacted must be discarded! If the pipeline is to be installed horizontally in the open, support points (for example, using sand) must be provided to prevent the pipe from slipping later. If the ground is uneven, these supports must be provided every 25 metres.

When embedding pipe sections, a sufficiently free pipe length of 3 to 5 metres must be provided for installing the connecting systems. Where there is a change of

material from steel to plastic medium pipe, stress may be transferred from the steel to the plastic pipe during temperature changes. In this case, shear forces particularly are to be avoided; if necessary, provide fixed points around the ends of the steel medium pipe. If installing in extremely low temperatures (increased pipe rigidity), the pipes should be stored in a heated hall or carry out the installation beneath a heated shelter directly at the trench.

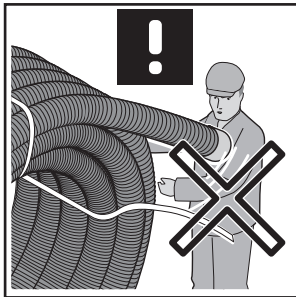

Fig. 1



Fig. 2



### WARNING!

The pipe ends could whiplash when the textile tapes are opened (see Fig. 1). Therefore make sure the coils are always secured with two to three tapes. (see Fig. 2).

### Rolling out the pipes from the inside (recommended for jacket pipe diameters 68 mm – 175 mm or coiled lengths up to 50 m):

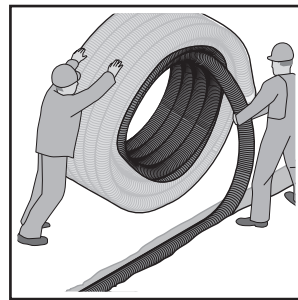

Do not remove exterior packaging! Cut the nylon securing tapes in the coil. Take out the inner pipe end from the coil (do not remove the end cap until the pipe is connected!). Fix the pipe ends (e.g. by weighing them down or placing sand on top of them). Roll out the pipe, coil by coil.

### Rolling out the pipe from the outside (recommended for jacket pipe diameters 68 mm – 250 mm or coiled lengths in excess of 50 m):

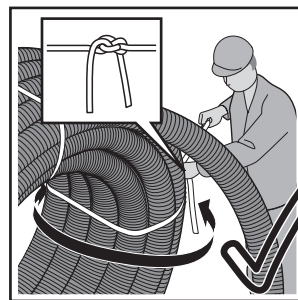
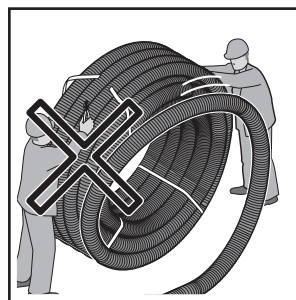
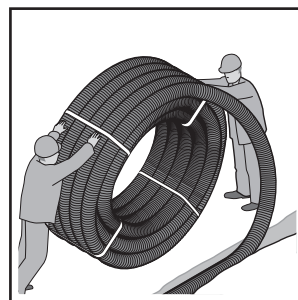

Remove the packaging foil. Open the first nylon tape at the outside pipe end, loosen the pipe end from the coil and fix the coil once more with the nylon tape. Warning – when opening the first nylon tape, the pipe end is under tension and can whiplash! Fix the loose pipe end (e.g. by weighing it down or placing sand on it) and roll out as far as the next nylon tape. Repeat this process until the coil is completely unrolled.

## Bending radii

Thanks to their structure and to the materials used, the flexible, pre-insulated pipe systems are extraordinarily flexible. The smallest permitted bending radii listed in the technical specification tables of the pipes must be taken into account when the pipes are laid.



### CAUTION!

The medium pipe can kink or be damaged if the bending radius is smaller than the specified minimum.

## Installation in cold temperatures

The installation is not recommended to be carried out in temperatures below  $-15\text{ }^{\circ}\text{C}$ . In cold weather, installation is easier if the pipes are already warm, for example from having

been stored in a warm space prior to the installation. On a construction site, heating can also be carried out using a hot air blower. Heating the pipes over an open fire is prohibited.

## Mounting on the wall or on the ceiling

The pipes can also be mounted on the wall or on the ceiling using brackets or placing them on a cable shelf. In order to prevent bending the pipe, install the brackets according to the adjacent table. The table sets out

maximum support intervals for horizontal and vertical mounting in order to prevent the pipes from hanging. If required, the interval of the brackets can be shortened.

Jacket pipe OD [mm]	Maximum support interval [m]
68	0.6
90	0.8
140	1.0
145	1.0
175	1.2
200	1.4
250	1.6

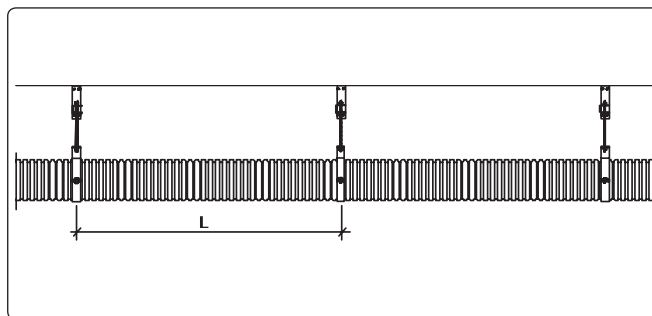



## Anchoring

The expansion behaviour of PEX material leads to slight changes in the length of the medium pipe therefore a tension-free connection must be provided by a pipe bend or a fixed point joint.

Small pipe sizes (medium pipe OD ≤ 50 mm) can normally be anchored with the holders of the joined piece of the equipment. Large pipe sizes (medium pipe OD > 50 mm) must be anchored using a separate fixed point joint.

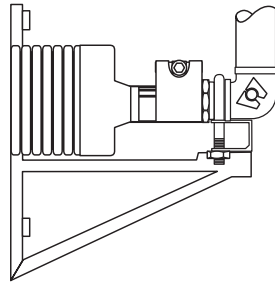

Fixing to pipe elbow with a pipe clamp (OD ≤ 50 mm)

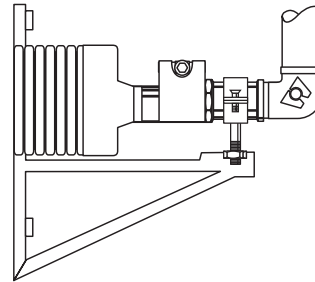

Fixing to a fixed point joint with a pipe clamp (OD > 50 mm)

### PLEASE NOTE!

Anchoring must not be conducted directly on the medium pipe.

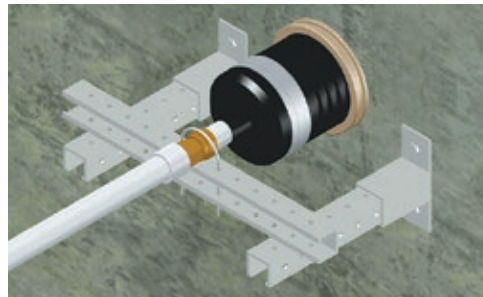

Anchoring

## Thermal elongation

Example thermal elongation of PE-Xa pipe:

Installation temperature = 20 °C  
Operation temperature = 70 °C

Result:  
Temp. difference = (70 °C - 20 °C)  
= 50K

Elongation (change length) =  
8,2 mm/m

A 5m pipe would expand by  
41 mm.

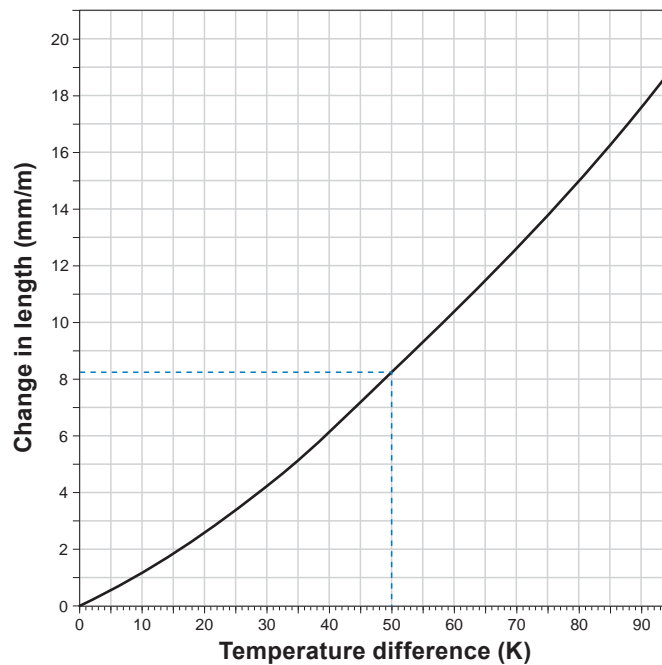

# Pressure and leak testing

## Pressure and leak testing for heating pipes according to DIN 18380

### Notice

The pressure test must take place before operation of the system begins. In order to ensure that the joints are not leaking, the test must be carried out before they are insulated and closed.

### Performance of the pressure test

The pipes that have been assembled, but not yet covered, are to be filled with filtered water in such a way as to exclude air. Heating pipes are to be tested using a pressure that is 1.3 times the total pressure (static pressure) of the installation, but that is at least 1 bar gauge

pressure at every part of the installation. Only pressure gauges that allow pressure changes of 0.1 bar to be read properly may be used. The pressure gauge is to be located at the lowest possible part of the installation.

Temperature equalisation between the ambient temperature and the temperature of the water with which the pipes are filled is to be achieved by a suitable waiting time after establishing the test pressure. After this waiting period it may be necessary to re-establish the test pressure.

The test pressure must be maintained for 2 hours, and must

not fall by more than 0.2 bar. No leaks may appear during this period. As soon as possible after the cold water pressure test, the temperature is to be increased to the highest hot water temperature on which the calculations were based, in order to check whether the installation remains free from leaks even at the maximum temperature. When the installation has cooled down, the heating lines are finally to be checked to see that there are no leaks at the joints.



### PLEASE NOTE!

The local requirements for pressure and leak testing can differ from the following examples.

## Pressure and leak testing for tap water application according to DIN 1988 Part 2

### Notice

The pressure test must take place before operation of the system begins. In order to ensure that the joints are not leaking, the test must be carried out before they are insulated and closed.

### Performance of the pressure test

The pipes that have been assembled, but not yet covered, are to be filled with filtered water in such a way as to exclude air. The pressure test is carried out as a preliminary and a main test.

### Preliminary test

For the preliminary test, a test pressure equal to the permitted operating pressure plus an additional 5 bar is applied; this must be repeated twice within 30

minutes, and with an interval of 10 minutes between tests. Following this, and after a test period of a further 30 minutes, the test pressure must not fall by more than 0.6 bar (0.1 bar every 5 minutes), and no leaks may appear.

### Main test

The main test is to be carried out immediately after the preliminary test. The duration of the test is 2 hours. In this test, the test pressure measured at the end of the preliminary test must not fall by more than 0.2 bar during the following two hours. Leaks may not be found at any point in the tested installation.

### Plastic pipes

The properties of the materials of which plastic pipes are made

cause the pipe to expand during the pressure test, and this has an effect on the test result.

The result of the test can also be affected by temperature differences between the pipe and the test medium, due to the high coefficient of thermal expansion of plastic materials. A temperature change of 10 K here corresponds approximately to a change in pressure of between 0.5 and 1 bar. For this reason it is necessary to keep the temperature of the test medium as constant as possible when parts of the installation comprising plastic pipes are being subjected to the pressure test. Check all the joints visually at the same time as the pressure test. Experience shows that relatively small leaks cannot always be detected simply by watching the pressure gauge. When the pressure test is complete, flush the pipes thoroughly.

### Pressure test graph

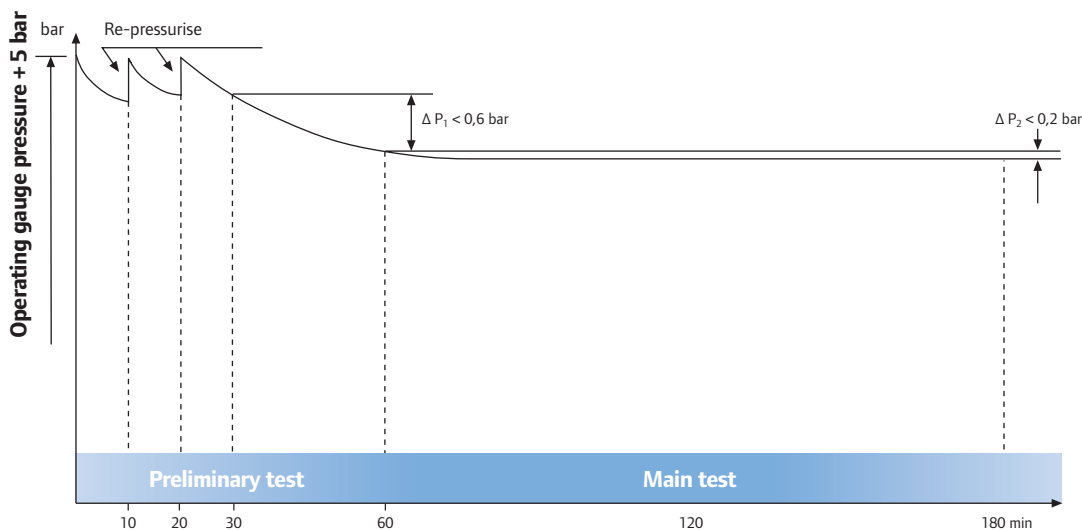

Pressure test record according to DIN 1988 Part 2 for water pipes

**Building project** \_\_\_\_\_

**Section** \_\_\_\_\_

**Client** \_\_\_\_\_

**Installing firm** \_\_\_\_\_

**Temperatures** Water temperature \_\_\_\_\_ °C Ambient temperature \_\_\_\_\_ °C

Pipes filled with filtered water to exclude air

**Preliminary test**

(also counts as the main test in special cases)

Test duration: 60 minutes Test pressure: Operating gauge pressure + 5 bar

Pressure after 30 minutes (start of test) \_\_\_\_\_ bar

Pressure after 60 minutes (final pressure) \_\_\_\_\_ bar (max. pressure drop 0,6 bar)

**Result of preliminary test**

\_\_\_\_\_

Detectable leaks

**Main test**

Test duration: 120 minutes maximum permitted pressure drop: 0,2 bar

Pressure at start of test \_\_\_\_\_ bar (final pressure of preliminary test)

Pressure after 120 minutes (final pressure) \_\_\_\_\_ bar (max. pressure drop 0,2 bar)

**Result of main test**

\_\_\_\_\_

Detectable leaks

\_\_\_\_\_  
Start of test

\_\_\_\_\_  
End of test

\_\_\_\_\_  
Location

\_\_\_\_\_  
Date

\_\_\_\_\_  
Client (Representative)

\_\_\_\_\_  
Installing firm (Representative)



# Product line components

## Uponor Wipex fitting range

The Wipex coupling is specifically designed for connecting cross linked polyethylene pipes, produced by Uponor, for hot and cold water in domestic and district heating installations. The coupling is available for pipe dimensions 25-110 mm, in two series marked PN 6 and PN 10.

The Wipex coupling is designed to give an excellent tight grip. The gripping strength is higher than the tensile strength of the pipe, and the sealing performance is unaffected by temperature fluctuations.

Wipex couplings are robust and simple in design, can be fitted very easily and quickly even in difficult locations and confined spaces. The ring spanners used when fitting the coupling are very small and convenient to use in relation to the size of the coupling.



### Benefits:

- The Wipex coupling is patented, tested according to DVGW (Germany), NKB (Sweden), CSTB (France), KIWA (Holland) and approved.
- The main components of the fittings are made of DR brass (resistant to dezincification).
- O-rings are used to make a seal between the couplings and pipe fittings.
- Additional sealing using teflon or hemp is not required
- The Wipex fitting system allows for an extremely wide range of connection combinations.
- No special tools required - only two fixed wrenches and a plier.



### Design

#### recommendation:

When connecting from the Uponor Wipex system to third-party components, the terminating Uponor Wipex element must consist of a fitting (bend or socket) with an inside thread.

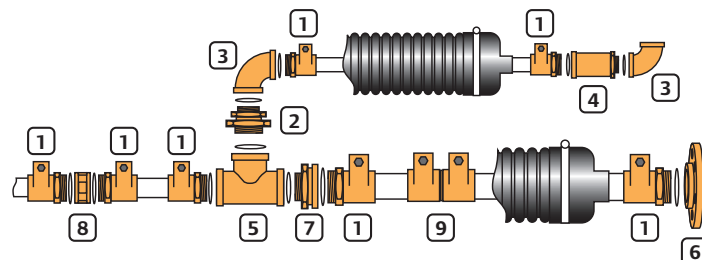

Uponor WIPEX jointing technology

- |                      |                           |                        |
|----------------------|---------------------------|------------------------|
| 1 Wipex coupling     | 4 Wipex fix point bushing | 7 Reducer              |
| 2 Wipex swivel union | 5 Wipex tee               | 8 Wipex sleeve         |
| 3 Wipex elbow        | 6 Wipex flange            | 9 Wipex jointing equal |



## Uponor Wipex S-Press adapter PN6 for the dimensions 32, 40, 50 mm

The Uponor Wipex S-Press adapter enables the direct system transition from the Uponor Ecoflex PE-Xa or PE 100 pipes with the Uponor multi layer composite pipe system for drinking water and heating installations.

All installations inside and outside the building can be done with Uponor proofed system components.

This saves time and provides additional installation reliability for the system transition. The adapters don't require any sealants such as hemp or Teflon for the installation.

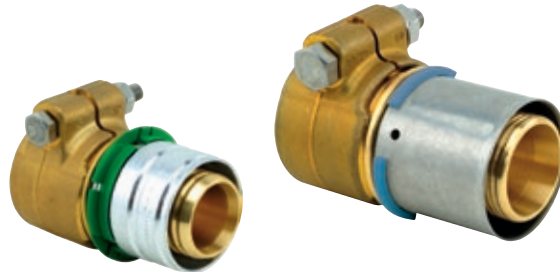

## Uponor Modular fitting System with WIPEX and Q&E

The innovative Uponor Riser System is a development that makes it possible to combine the modular riser system (MLCP) with WIPEX and Q&E fittings.

This fitting system reduces both planning and construction work, because it is quicker and easier to connect our multi layer and PE-Xa pipes together.



## Uponor Ecoflex compression adapters for dimension 18, 20, 22 mm

The Ecoflex adapter is designed for connecting cross linked polyethylene pipes in warm tap water installations. The adapters are available for pipe dimension 18x2,5mm, 20x2,8mm, 22x3,0mm, PN 10. Hemp is used for sealing.



Uponor Ecoflex compression adapter

## Uponor Ecoflex coupling for 125 mm

The Ecoflex coupling is designed for connecting cross linked polyethylene pipes for district heating installations. The coupling is available for pipe dimension 125 x 11.4 mm, PN 6 and fitting base parts in 4 inch. Hemp is used to make a seal between the couplings and base parts.

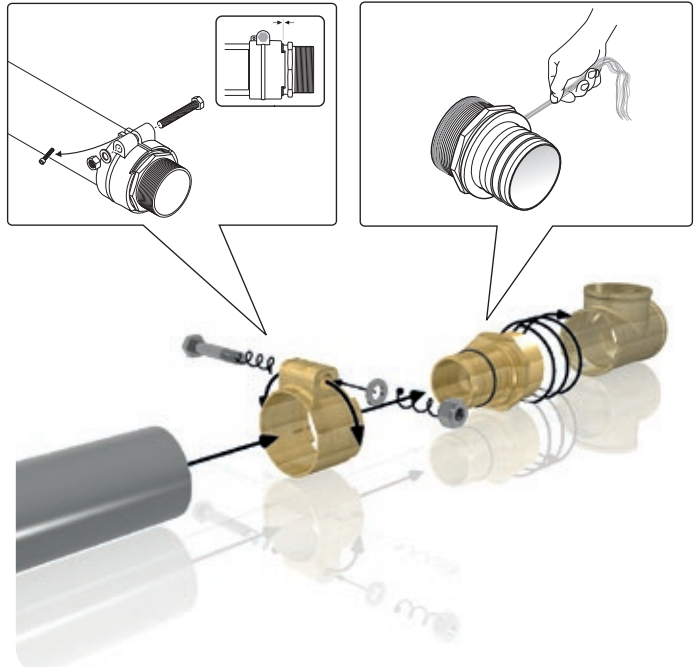

Uponor Ecoflex coupling for pipe dimensions 125 x 11.4 mm, PN 6

## Uponor Ecoflex Supra plastic coupling

The Uponor Ecoflex plastic coupling has been tried and proven over many years as the perfect connection for HDPE medium pipes. The simple handling of this clamping fitting provides, on the one hand, a safe connection and on the other hand rapid progress in installing Supra pipe systems.

Also the Supra pipes can be connected by electro-welding-fittings, which are approved for PE 100, SDR 11 pipes (not provided by Uponor flexible, pre-insulated systems).



Uponor Ecoflex Supra plastic coupling



Electro-welding-fitting

## Uponor Q&E fitting range

The system is based upon the unique properties of Uponor PE-Xa pipes and the revolutionary Q&E fitting. The mounting is simple as just an expander tool is needed. Only expand the Uponor PE-Xa pipe together with a Q&E Ring and mount it directly onto the brass or PPSU fitting. The pipe will shrink back and the mounting is complete. The technique has been patented by Uponor and is designed exclusively for Uponor PE-Xa pipe up to dimension 75 mm. The fittings have been tested in performance by several independent official accredited laboratories, such as ATG Belgium, KIWA Netherland, MPA Germany, SP Sweden, TGM Austria, QAS Australia as well as in Uponor own laboratories.



### Benefits:

- A total and safe solution for a professional installer
- A simple and reliable fitting design without O-rings, press or push sleeves, which make it easy to use and fast to fit
- By the use of Q&E, a professional makes the installation fast and efficiently
- Once connection is made the joint is non-removable



## Uponor Ecoflex jacket joint set

For sealing straight jacket pipe connections of Ecoflex preinsulated pipes. Set contains two shrink sleeves and a corrugated PE pipe sleeve.



## Uponor Ecoflex rubber end caps

Uponor Ecoflex rubber end caps protect the insulation at cut pipe ends and provide partitions between components. It is important to provide this protection against moisture ingress or

damage, so that the whole system can fulfil its purpose optimally over many years. A sealing ring is also supplied to prevent the entry of water. The end caps can be assembled by eas-

ily and conveniently pulling them over the ends of the pipes, after which they are fully secured with a clamping ring.



Single



Twin



Quattro

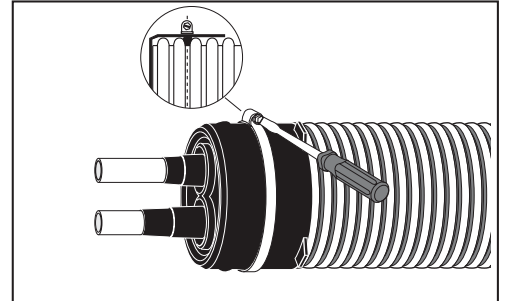
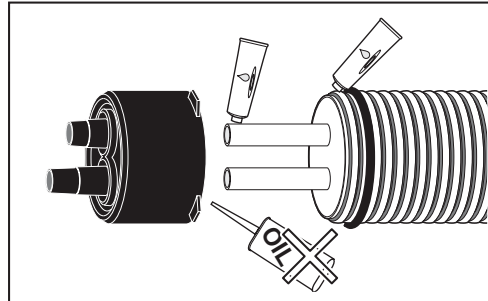
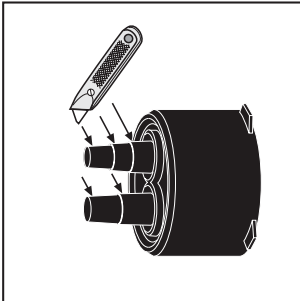

### Mounting the rubber end cap

#### NOTE!

The rubber end caps must be fitted to the ends of the jacket pipes before making a fitting connection to a medium pipe.

#### NOTE!

Before the rubber end caps are fitted, the insulation must be removed from the pipe back to the proper length. The dimensions of the insulating kit must be observed here.

#### NOTE!

Not required for Thermo PRO pipes.

#### NOTE!

Clamping ring is not needed when using the Uponor Ecoflex H-insulation set.



## Uponor Ecoflex insulation sets

The selection of insulation includes different T-sets, one elbow, one straight set and two reducer kits. Due to its special design and high quality ABS material the insulation sets

resist a traffic load of 60tons. Additionally the insulation sets are mounted with foam half shells which ensure less heat loss during operation. All sets cover three different dimensions

of jacket pipes and they fit single and twin pipes equally well. All necessary components like foam half shells, bolts, sealing kit are included.



Uponor Ecoflex T-insulation set



Uponor Ecoflex elbow insulation set



Uponor Ecoflex straight insulation set



Uponor Ecoflex H-insulation set

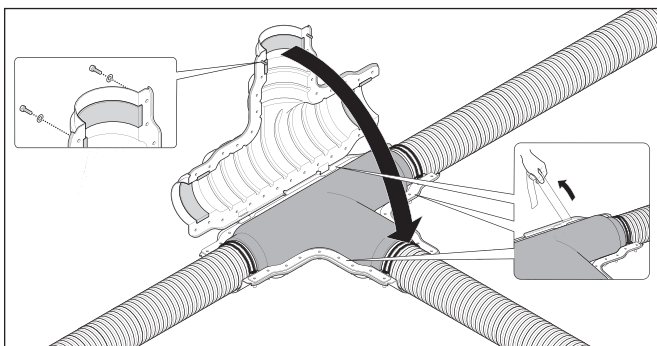

Mounting the T-insulation set

### NOTE!

Joints should not be located underneath roads because this makes access difficult and heavy vehicles could damage the joint.

If the H-insulation set is installed underneath roads it is necessary to use a concrete slab above the joint to distribute the heavy traffic load.

The Uponor Ecoflex H-insulation set should not be used with Uponor Ecoflex Thermo PRO pipes.

## Uponor Ecoflex house connection elbow Single/Twin

Uponor offers the pre-insulated Ecoflex house connection elbow to simplify house entry through the floor slab with minimal bending radius. It consists of PUR foamed PE-Xa medium pipes with PE-HD outer jacket

### Dimensions

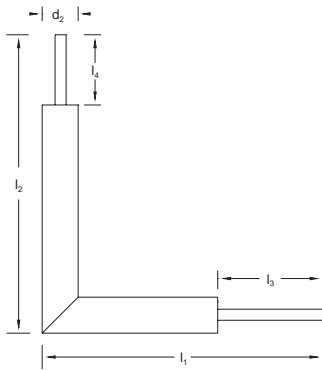

Type	dxs [mm]	Service pipes [n]	d <sub>2</sub> [mm]	l <sub>1</sub> [mm]	l <sub>2</sub> [mm]	l <sub>3</sub> [mm]	l <sub>4</sub> [mm]	weight [kg]
Single	75x6,8	1	205	1600	1700	600	400	15,2
Twin	50x4,6	2	205	1600	1700	600	400	14,1
Twin	63x5,8	2	205	1600	1700	600	400	17,3
Twin	75x6,8	2	250	1600	1700	560	375	24,2

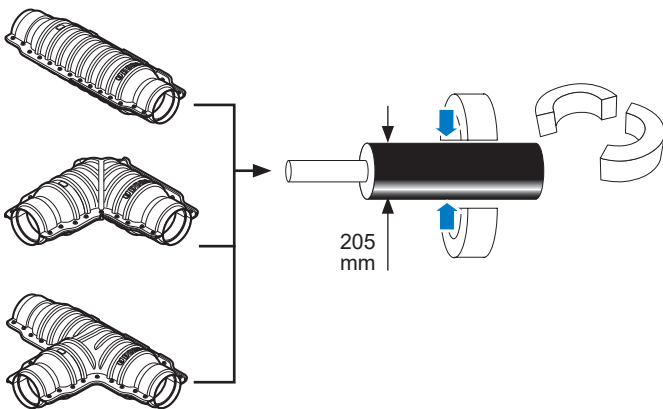

### Installation

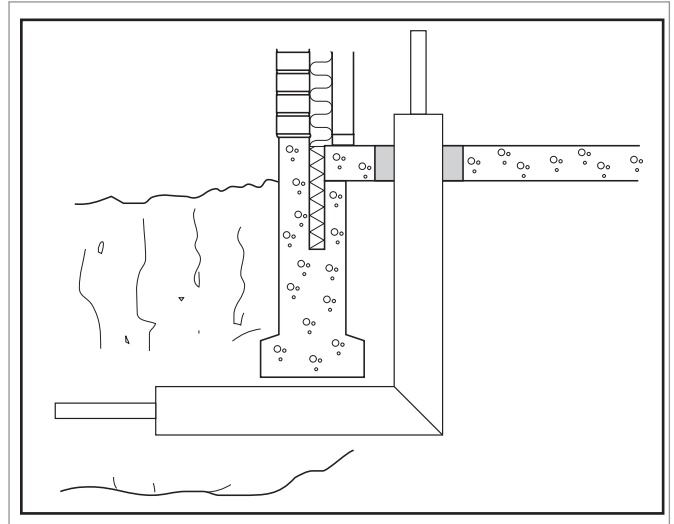

#### NOTE!

The house connection elbows (except for Twin 75) are supplied with Ecoflex insulation set. Therefore the Ecoflex reducer ring 200/205 (Item No. 1085106) must be used.

The house connection elbow Twin 75 will be connected with the jacket joint set 250 (Item No. 1083872).

## Uponor Ecoflex chamber

Uponor connecting chambers are designed for pipe joints that cannot be made with an Uponor insulation kit. This includes, for instance, connections between single to two or more twin

pipes, or for the Uponor Ecoflex Quattro pipes. The rotationally moulded chamber has walls made of polyethylene and, on the inside, it is coated with a PE insulant. The branching cham-

ber enables the joining of other connections at a later date. The chamber has a watertight structure and is suitable for all pipe dimensions (casing pipe size 140, 145, 175, 200 and 250 mm).



### NOTE!

Joints should not be located underneath roads because this makes access difficult and heavy vehicles could damage the joint.

Without load distribution above the chamber, the chamber can handle with 50 cm sand cover a short-term load of 3,000 kg (6,000 kg / m<sup>2</sup>) - e.g. tractor crossing. The chamber lid can withstand a continuous load of up to 500 kg (1,000 kg / m<sup>2</sup>), e.g. a parked car.

At higher traffic load it is necessary to use a concrete slab above the chamber to distribute the load.



The rotomolded chambers are made of polyethylene. The insulation layer on the inside ensures minimized heat losses.

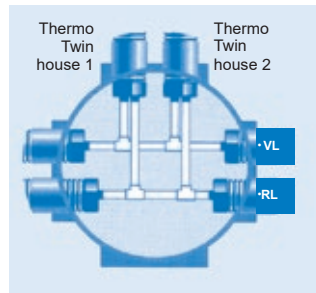

Heating supply from the main line to 2 houses

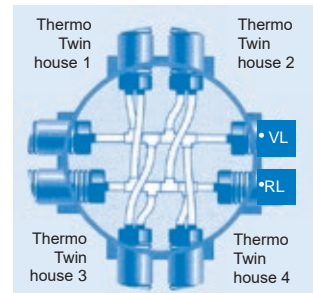

Heating supply from the main line to 4 houses

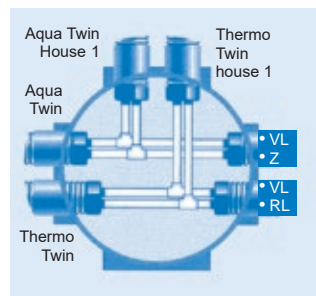

Heating and tap water from the main lines to the house

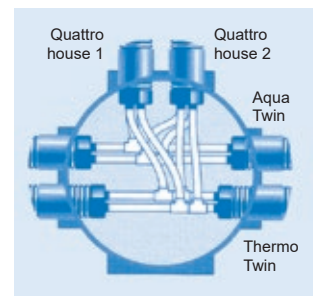

Heating and tap water from the main line to 2 houses using Quattro

## Uponor Ecoflex wall ducts

### Wall sleeve set NPW (non-pressure-waterproof)

This wall sleeve can be used for the feed-through in building foundations wherever there is no pressurized water. Wall sleeve is mounted in place when the foundations are cast or is installed in a hole drilled afterwards. The shrink sleeve prevents water from leaking into the foundations between the pipe and the wall sleeve. The set contains a 550 mm long wall sleeve and a wide shrink sleeve.

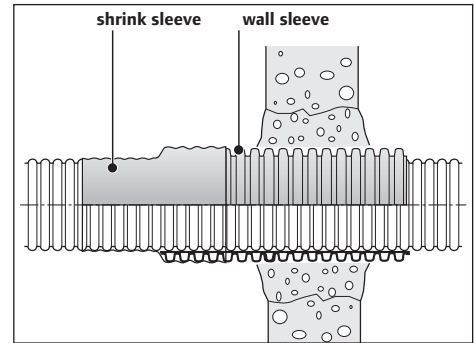

Jacket pipe size [mm]	Sleeve pipe outer diameter [mm]
68/90	110
140	200
175/200	250
250	315

### Wall through sealing NPW (non-pressure-waterproof)

Efficiently seals the feed-through in a concrete structure and prevents moisture from entering the building. Radon sealing has also been tested. The set contains the wall through sealing and the clamping ring.

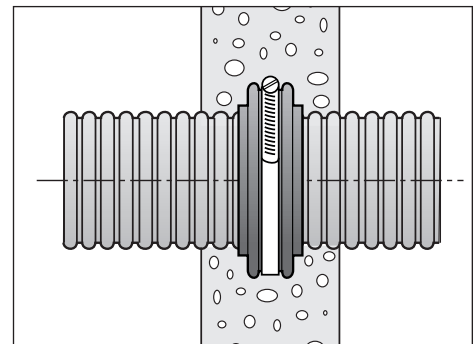

Jacket pipe size [mm]	Outer diameter of sealing* [mm]
140	190
175	225
200	250
250	300

\* Excluding 5 mm for tensioning screw.

## Uponor Ecoflex wall seal PWP (pressure-waterproof)

### Wall seal PWP

An Uponor Ecoflex wall seal PWP must be used wherever water at pressure is to be expected. They can either be used directly in a coated tapping drill hole into waterproof concrete, or in a fibre cement pipe that is concreted or bricked into place.



### Additional insert PWP

If it is not possible to introduce the jacket pipe perpendicularly into the wall duct, we recommend that the Uponor Ecoflex additional insert is used to disperse any possible stresses.



Jacket pipe size [mm]	Core hole [mm]
68	125
140	200
175	250
200	300
250	350

### Epoxy resin set PWP

Before an Uponor Ecoflex wall seal PWP is fitted into a tapping drill hole, it must be coated with epoxy resin!



### Fibre cement pipe PWP

The wall seal PWP can also be mounted into an Uponor Ecoflex fibre cement pipe PWP. The fibre cement pipe can be fixed in a brick wall or poured in a concrete wall.

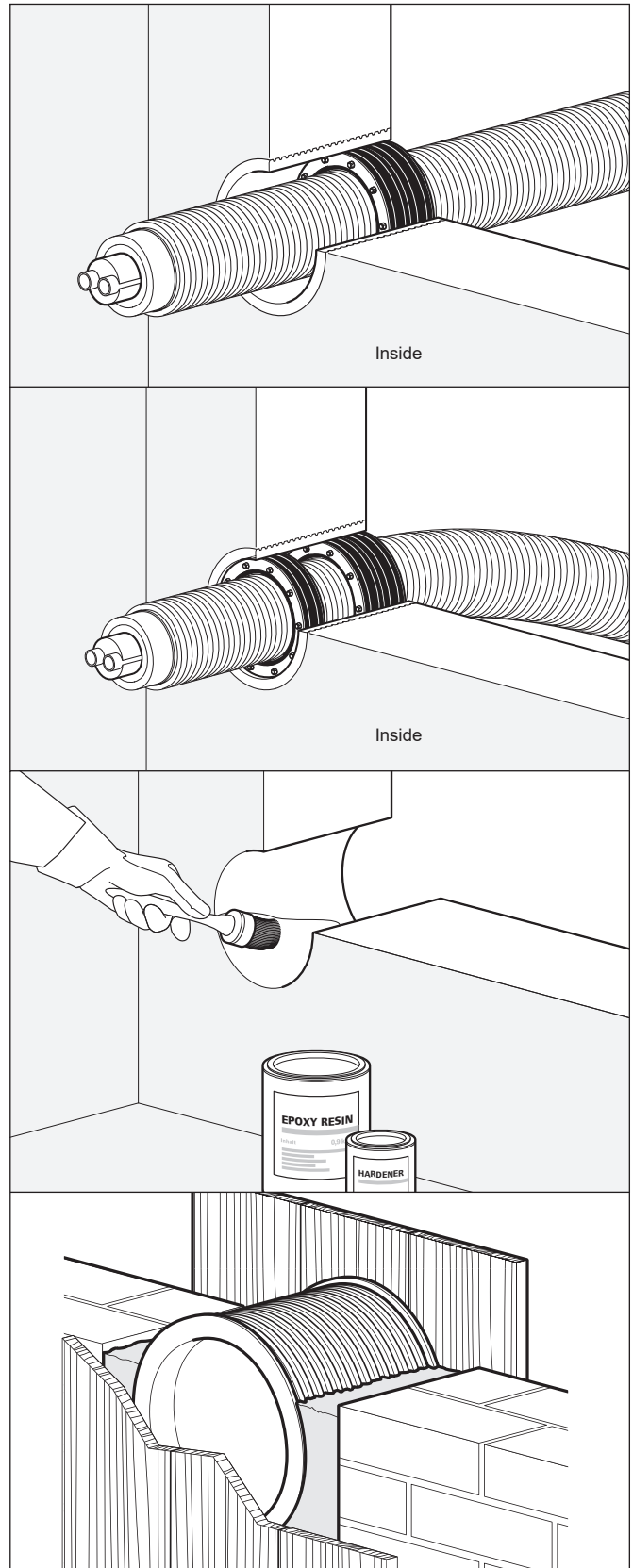

### Uponor Ecoflex house lead-in, pressure water proof

Alternatively to the Uponor Ecoflex wall seal PWP can also our Ecoflex house lead-in, PWP (up to max. 1 bar) be used in a on-site core hole. The jacket pipe is wrapped with a sealing tube and slide into the coated bore. Then the gap on both sides (outside and inside) will be filled with an expansion resin.

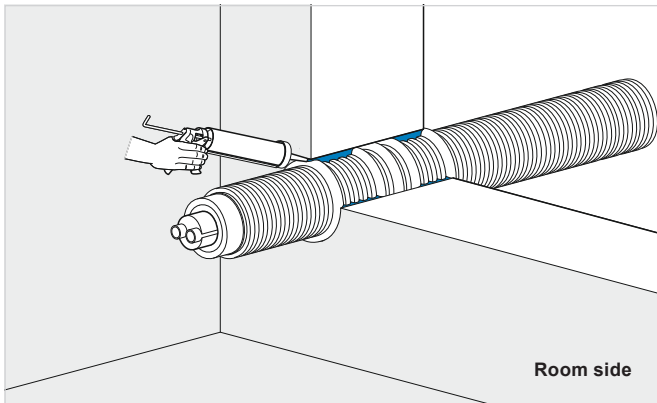

Uponor Ecoflex house lead-in, PWP



Uponor Ecoflex house lead-in, PWP and Ecoflex house lead-in paste for coating the core hole.

outer diameter jacket pipe [mm]	inner diameter core hole [mm]
175	195 – 200
200	220 – 225

#### Installation note:

We recommend to use the Uponor Ecoflex house lead-in PWP paste before installation of the Ecoflex house lead-in PWP.



## Additional accessories

Damaged jacket pipes can be repaired easily and reliably with the Uponor Repair shrink sleeve.

The Uponor Ecoflex trench warning tape is laid above the flexible, pre-insulated pipe to mark and identify it.

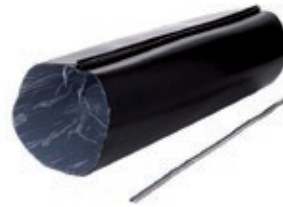

Ecoflex repair sleeve



Ecoflex trench warning tape

For supporting pipes exactly into place in base floor feed-throughs. Several pipe bend supports can be joined together side by side.

The conduit angle is used as a casing pipe when leading insulated pipe elements into buildings. Material is PVC plastic.



Ecoflex pipe bend support



Ecoflex conduit angle



Ecoflex shrinkable tape



Ecoflex shrink sleeve

# Uponor Ecoflex Supra

Technical Information

Pre-insulated pipes for cold water service

Uponor Ecoflex Supra, Supra Plus, Supra Standard

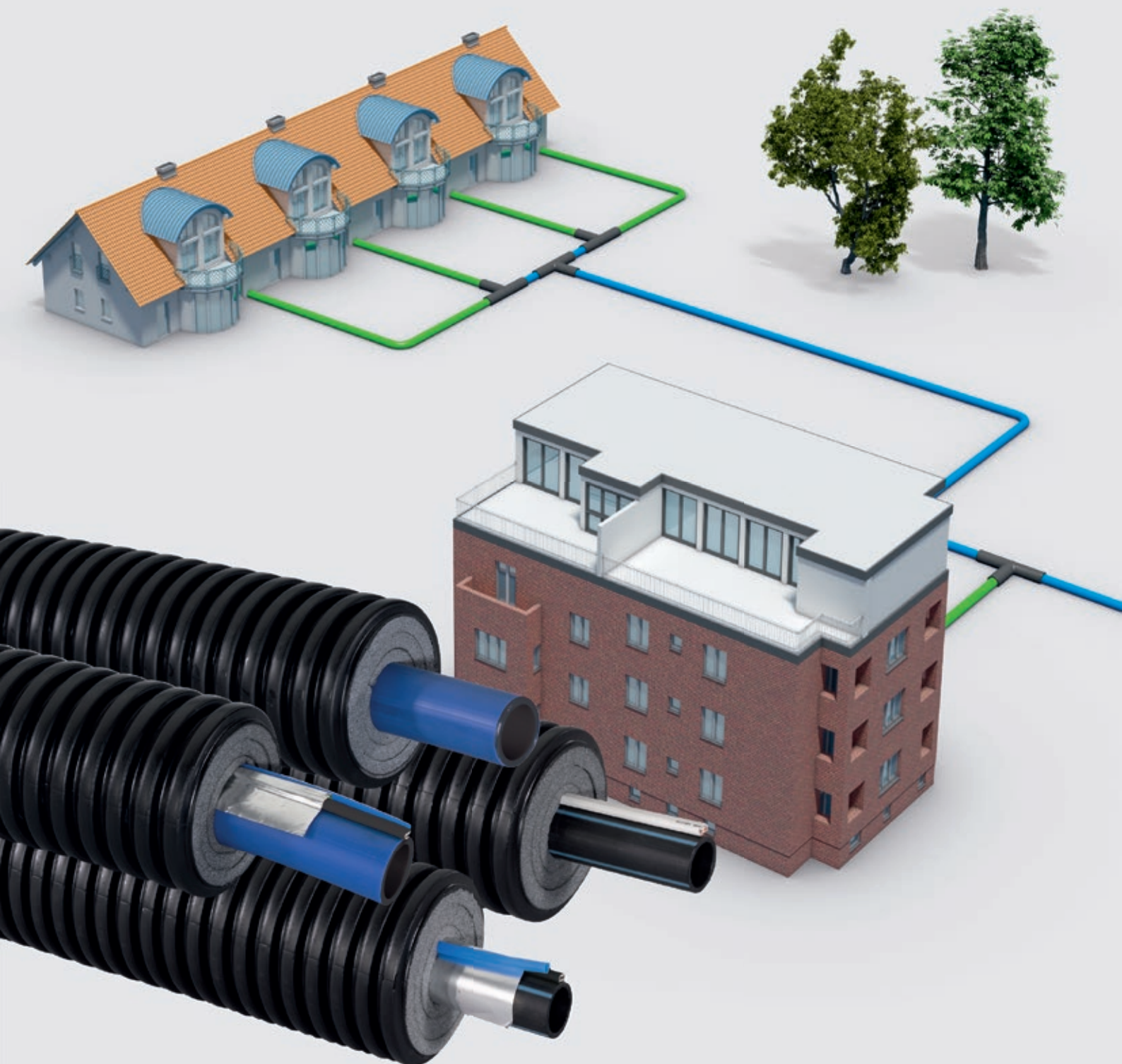

# Uponor Ecoflex Supra: reliability for cold water supply and cooling networks

Reliability for cold water supply and cooling networks, Uponor Ecoflex Supra pipes are the preferred solution for cooling water networks in holiday resorts, hotel complexes or industrial facilities. Supra is optimized for use in applications at temperature from -10 °C to +20 °C. Easy and fast

installation and low need for maintenance ensure carefree and cost-efficient life cycle of the system. Cooling capacity is optimized by efficient thermal insulation and a securely tight construction of the pipes and joints.

## Pipe design



### 1 HDPE jacket pipe

The jacket pipe of Uponor Ecoflex pipes are made of high impact-proof HDPE. A special corrugated rib profile provides high flexibility as well as high degree of static load resistance (ring stiffness according EN ISO 9969). The pipe is suitable for loading by heavy traffic (SWL 60 = 60 t) according to worksheet **ATV-DVWK-A 127**.

### 2 Insulation

The insulation is made of crosslinked polyethylene foam. The closed-cell structure of the insulation prevents water absorption < 1 Vol.% and provides good insulation capacity. The foamed plastic density is 25 – 30 kg/m<sup>3</sup> and thermal conductivity 0.038 W/mK at 40 °C. The multi-layer insulation ensures high flexibility.

### 3 Service pipe

The service pipe is produced of double layer PE 100 according DIN EN 12201 with maximum safety and service life. Referred to these standard, the pipes are approved to a pressure of 16 bars. The service pipes are resistant against many aggressive media.

## Uponor Ecoflex Supra

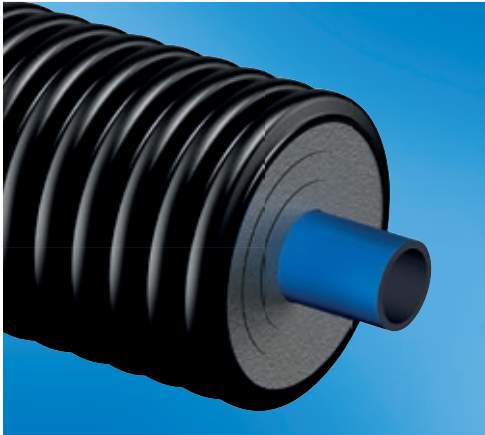

20 °C



16 bar



25 – 110 mm

### Main application

- Potable water, cold
- Cooling water

### Other applications

- Sewage water

### Medium pipe

- HDPE (PE 100), SDR 11

### Insulating material

- PE-X foam

### Material jacket pipe

- HDPE

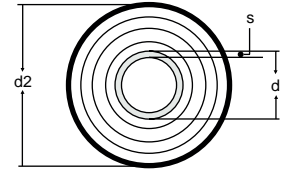

### Note!

Uponor Ecoflex Supra is optimized for applications at temperatures from -10 to +20 °C.

## Uponor Ecoflex Supra offering

Item no.	Medium pipe d x s [mm]	DN [mm]	Jacket pipe d2 [mm]	Bending radius [m]	Weight [kg/m]	Max. length on delivery [m]
1018124	25 x 2.3	20	68	0.20	0.52	200
1018125	32 x 2.9	25	68	0.25	0.62	200
1018126	40 x 3.7	32	140	0.30	1.47	200
1018127	50 x 4.6	40	140	0.40	1.67	200
1018128	63 x 5.8	50	140	0.50	1.97	200
1018129	75 x 6.8	65	175	0.60	2.72	100
1018130	90 x 8.2	80	175	0.70	3.14	100
1018131	110 x 10.0	100	200	1.20	5.24	100



# Uponor Ecoflex Supra PLUS: carefree living even in cold temperatures

Uponor Ecoflex Supra PLUS is an insulated polyethylene pipe for water pipe installations likely to get frozen. It is a good choice for one-family homes, farms and cottages situated in remote locations. Supra PLUS is supplied on a maximum 150 m pipe coil completely ready for installation. The self-regulating heating cable makes it possible to cut the Supra PLUS pipe at the required length. The service

pipe sizes are Ø 25 – 110 mm. The maximum pressure for the PE 80 service pipe (25 – 63 mm) is 12.5 bar and 16 bar for the PE 100 service pipe (75 – 110 mm). The service pipe can be connected with Uponor Wipex coupling, electrofusion fittings or plastic screw fittings which are approved for PE 100, SDR 11 pipes from sources in the market worldwide.

## Pipe design



### 1 Service pipe PE 80/PE 100

The service pipe has been developed for conveying cold tap water. The service pipes are made of PE 80 (25 – 63 mm) and PE 100 (75 – 110 mm).

### 2 Heating cable

The self-regulating heating cable has a nominal output of 10 W/m and supply voltage of 230V.

### 3 Aluminium foil

Aluminium foil intensifies power transmission from the cable to the service pipe.

### 4 HDPE jacket pipe

The HDPE jacket pipe of Uponor Ecoflex pipes are made of corrugated HD polyethylene. Corrugation makes the casing robust against heavy traffic load but keeps flexibility for the installation.

### 5 Insulation

The insulation is made of crosslinked polyethylene foam. The closed-cell structure of the insulation prevents water absorption and provides good insulation capacity. The foamed plastic density is 25 – 30 kg/m<sup>3</sup> and thermal conductivity 0.040 W/mK at 40 °C

### 6 PE sensor conduit

The PE sensor conduit for installing the control unit sensor.

## Uponor Ecoflex Supra PLUS



20 °C



12.5 or 16 bar



25 – 110 mm

### Main application

- Transport of cold water
- Freeze-protection

### Other applications

- Sewage water

### Medium pipe

- MDPE (PE 80, SDR 11, Dim. 25-63 mm)
- HDPE (PE 100, SDR 11, Dim. 75-110 mm)

### Insulating material

- PE-X foam

### Material jacket pipe

- HDPE

### Cable

- Self-regulating

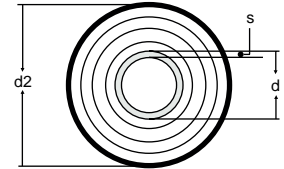

## Uponor Ecoflex Supra PLUS offering

Item no.	Medium pipe d x s [mm]	DN [mm]	Jacket pipe d2 [mm]	Bending radius [m]	Weight [kg/m]	Max. length on delivery [m]
1048687	25 x 2.3	20	68	0.20	0.58	150
1048688	32 x 2.9	25	68	0.25	0.67	150
1048689	40 x 3.7	32	90	0.30	1.08	150
1048690	40 x 3.7	32	140	0.30	1.50	150
1048691	50 x 4.6	40	90	0.40	1.26	150
1048692	50 x 4.6	40	140	0.40	1.70	150
1048693	63 x 5.8	50	140	0.50	2.10	150
1048694	75 x 6.8	65	175	0.60	2.90	150
1048695	90 x 8.2	80	200	1.10	4.40	100
1048696	110 x 10.0	100	200	1.20	5.10	100



## Uponor Ecoflex Supra PLUS 16 bar

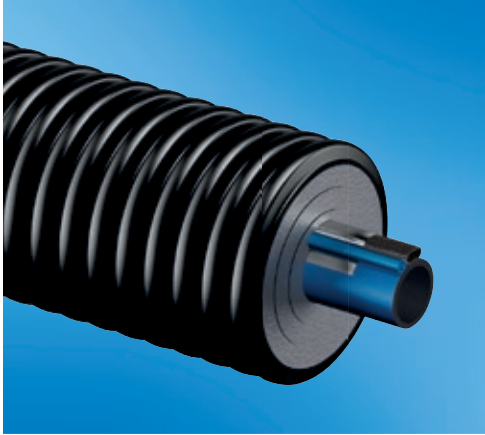

20 °C



16 bar



25 – 110 mm

### Main application

- Transport of cold water
- Freeze-protection

### Other applications

- Sewage water

### Service pipe

- HDPE (PE 100),  
SDR 11 (Dim. 25-110 mm)

### Insulating material

- PE-X foam

### Material jacket pipe

- HDPE

### Cable

- Self-regulating

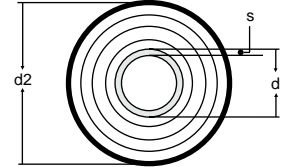

## Uponor Ecoflex Supra PLUS 16 bar offering

Item no.	Medium pipe d x s [mm]	DN [mm]	Jacket pipe d2 [mm]	Bending radius [m]	Weight [kg/m]	Max. length on delivery [m]
1048902	25 x 2.3	20	68	0.20	0.52	150
1048903	32 x 2.9	25	68	0.25	0.62	150
1048904	40 x 3.7	32	140	0.30	1.62	150
1048905	50 x 4.6	40	140	0.40	1.82	150
1048906	63 x 5.8	50	140	0.50	2.12	150
1048907	75 x 6.8	65	175	0.60	2.87	100
1048908	90 x 8.2	80	175	0.70	3.29	100
1048909	110 x 10.0	100	200	1.20	5.39	100

# Uponor Ecoflex Supra PLUS: self-regulating cable and control unit

## Functionality of self-regulating heating cable

The self-regulating heating cable has been designed particularly to prevent the pipes from freezing. This feature combined with good insulation guarantees a frost free and safe solution. The heating part of the self-regulating heating cable is a conductive polymer extruded between two copper wires (phase and zero). In cold parts, a high current travels from one wire to another creating heat in the core material. In the warmer parts of the cable, the resistance of the material grows, the current flow slows down and heat output is reduced. The heat production of the cable remains balanced and the heating capacity is regulated according to ambient conditions separately in each part of the pipe (see cross-section image). In low temperatures, Supra PLUS provides adequate power to prevent freezing. As the temperature increases, the power is reduced. The self-regulating functionality of Supra PLUS pipes provides safe operation.

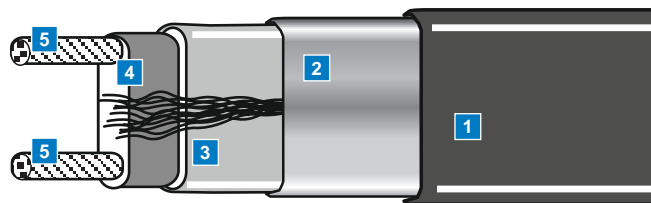

- 1 Outer jacket
- 2 Aluminum folio and drain wires
- 3 Electrical insulation
- 4 Core
- 5 Conductors

<b>External dimensions</b>	Width 12.5 mm, thickness 5.2 mm
<b>Smallest bending radius</b>	13 mm
<b>Supply voltage</b>	230 V
<b>The maximum permissible operating temperature</b>	Continuous 65 °C Momentary 85 °C
<b>Max. installation length</b>	100 m 10 A, 150 m 16 A
<b>Nominal output (on the surface of an insulated metal pipe +5 °C)</b>	10 W/m

## Operation

When the cable is cold, the resistor material contracts, opening several routes for power along the carbon crystals contained in the core material. The electrical current travelling through the core material creates the heat. In warm locations, the polymer in the resistor material expands

and the number of routes for the electrical current is reduced. This makes the resistance increase and the heat transfer capacity to decrease. In "hot" locations, the core material expands so that only a few routes are left for the power current in the core material. The result is a large resistance reducing the power transmission capacity further.

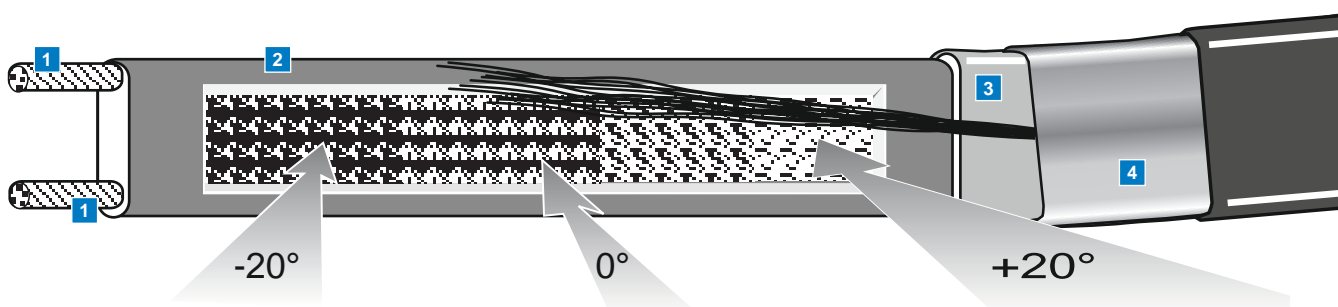

- 1 1.2 mm<sup>2</sup> copper wires copper wires
- 2 Self-regulation resistor material
- 3 Polyolefin insulation
- 4 Aluminum folio and drain wires

### The use of the cable

The heating cable of the Supra PLUS pipe is self-regulating and thus cannot overheat. The use of the heating cable is controlled using a control unit with timer and thermostat functions. Power supply to the heating cable is switched off from the operating switch when there is no risk of freezing. If the pipeline is in occasional use, the cable can also be used to defrost a frozen pipeline. The heating cable does not require maintenance. The heating cable must be switched off and protected from mechanical damage during any repairs to the pipeline. After repairs, the insulation resistance must be measured and entered in the test log.

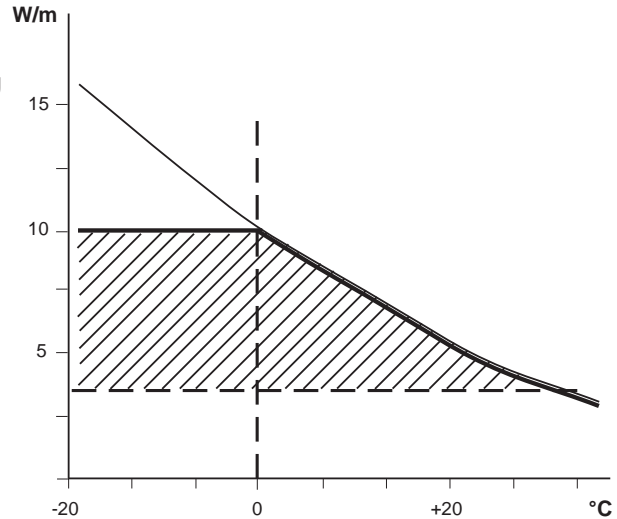

The heating cable supplies full power in ice, cold water or in frozen pipeline. The ruled area in the image shows the input power W/m depending on the outdoor temperature when the heating cable is on continuously.

### Uponor Ecoflex Supra PLUS control unit

The control unit is an electronic regulator designed for controlling the self-regulating Supra PLUS pipe equipped with a heating cable. The control unit has two different functions, either function with a temperature sensor or a fixed timer function (see on page 13).



Uponor Ecoflex Supra PLUS control unit	
Operating voltage	230 VAC
Rated power	1500 W
Operating temperature range	-20...+45 °C
Housing class	IP23
Indication by indicator light	effective part
Adjustment range	
- with thermostat	0...10 °C
- with operation	10 %...100 %

### Installation instructions

Fix the base of the housing to the wall with screws (hole interval 60 mm, maximum screw head diameter 6.5 mm). The tightness class of the surface installation housing is IP23. The housing can also be mounted on top of an instrument box, in which case the tightness class is IP20. The fixing holes are dimensioned according to the most generally used instrument boxes. On the back cover of the housing, for installation on top of an instrument box, an area with reduced thickness has been provided, which can be pierced for the lead-through of cables. Fix the cover of the housing to the base part with M2.5 screws. If the lead-through seals to be used are any other than those supplied in the package, then they must be approved for the cable thickness to be used and for tightness class IP23. Install the sensor in the installation tube of the Supra PLUS pipe. The sensor is supplied ready installed inside the insulating sleeve. Lead the insulating sleeve into the installation tube of the Supra PLUS pipe. The sensor should be installed in the location most susceptible to freezing. If the sensor cannot be installed in the coldest location, this must be taken into account when setting the thermostat or the timer.

## Connections

Remove the adjuster wheel, unscrew the mounting screw and remove the cover of the thermostat. Connect a 230V A/C supply cable (a), the sensor cable (b), the Supra PLUS heating cable (c) and the protective earthing on the incoming feed and heating cable protective braiding. The thickness of the connecting wires is determined according to the size of the main fuse. 10A -> 3 x 1.5 mm<sup>2</sup> and 16A -> 3 x 2.5 mm<sup>2</sup>. The installations should be carried out in accordance with the fixed installation method.

## Connections

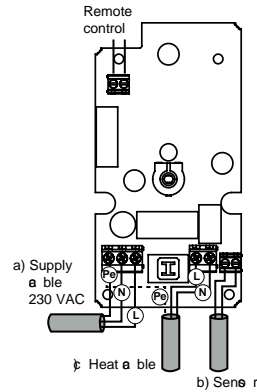

## Values of sensor

T [°C]	R [kΩ]
0	29
5	23
10	18
15	15
20	12
25	10



### Timer function

The timer is used to regulate the power supply to the cable. It is an easy way to reduce power consumption and to prevent the harmful heating of the water in the pipeline. The timer regulation area corresponds to a 30 minute switching cycle. On the maximum setting at 100%, the heating cable is on during the entire switching cycle. On the minimum setting at 10%, the heating cable is on for 3 minutes and off for 27 minutes. The switching cycle must be selected on a case by case basis according to the prevailing conditions. When using a timer to defrost a frozen pipe, the dial is set at 100%.



### Thermostat function

The thermostat function is used for controlling the cable when a certain pre-set temperature should not be exceeded. The temperature range controlled using the thermostat is 0 – 10 °C and control takes place with the adjuster wheel on the thermostat unit. The thermostat sensor is installed in the pipe element inside the feed pipe. The sensor installation location should be the location most susceptible to freezing. If the sensor cannot be installed in the location most susceptible to freezing, this should be taken into account by setting the thermostat maintenance temperature higher.

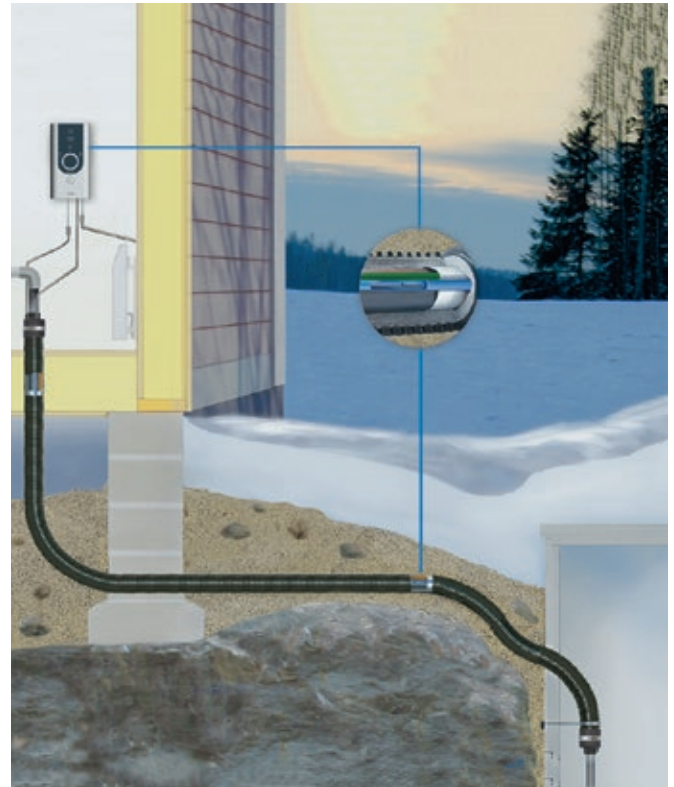

# Planning

## Dimensioning and thermal losses

The table shows the Uponor Ecoflex Supra PLUS element thermal losses in different ambient temperatures.

The temperature of the pipe contents has been assumed to be +2 °C. When thermal loss is less than 10 W/m, the cable output is enough to secure operation.

Temp. outside the pipe	Pipe dimensions																	
	25/68	* 25/90	* 25/140	32/68	* 32/90	32/140	40/90	40/140	* 40/175	50/90	50/140	* 50/175	63/140	* 63/175	75/175	* 75/200	90/200	110/200
0 °C																		
-1	1	1	0	1	1	0	1	1	0	1	1	1	1	1	1	1	1	1
-2	1	1	1	1	1	1	1	1	1	2	1	1	1	1	1	1	1	2
-3	1	1	1	2	1	1	1	1	1	2	1	1	1	1	1	1	1	2
-4	2	1	1	2	1	1	2	1	1	2	1	1	2	1	2	1	2	2
-5	2	1	1	2	2	1	2	1	1	3	2	1	2	2	2	2	2	3
-6	2	1	1	3	2	1	2	1	1	3	2	1	2	2	2	2	2	3
-7	2	2	1	3	2	1	3	2	1	4	2	2	3	2	3	2	3	3
-8	3	2	1	4	2	2	3	2	2	4	2	2	3	2	3	2	3	4
-9	3	2	1	4	2	2	3	2	2	4	2	2	3	2	3	3	3	4
-10	3	2	2	4	3	2	3	2	2	5	3	2	3	3	3	3	3	5
-11	3	2	2	5	3	2	4	2	2	5	3	2	4	3	4	3	4	5
-12	4	3	2	5	3	2	4	3	2	5	3	3	4	3	4	3	4	5
-13	4	3	2	5	3	2	4	3	2	6	3	3	4	3	4	4	4	6
-14	4	3	2	6	4	2	5	3	2	6	4	3	5	3	5	4	5	6
-15	4	3	2	6	4	3	5	3	3	7	4	3	5	4	5	4	5	6
-16	5	3	2	6	4	3	5	3	3	7	4	3	5	4	5	4	5	7
-17	5	3	3	7	4	3	5	3	3	7	4	3	5	4	5	4	5	7
-18	5	4	3	7	4	3	6	4	3	8	4	4	6	4	5	5	6	8
-19	5	4	3	7	5	3	6	4	3	8	5	4	6	5	6	5	6	8
-20	6	4	3	8	5	3	6	4	3	9	5	4	6	5	6	5	6	8
-21	6	4	3	8	5	4	7	4	4	9	5	4	7	5	6	5	7	9
-22	6	4	3	8	5	4	7	4	4	9	5	4	7	5	6	6	7	9
-23	6	5	3	9	6	4	7	5	4	10	6	4	7	5	7	6	7	9
-24	7	5	3	9	6	4	7	5	4	10	6	5	7	6	7	6	7	10
-25	7	5	4	10	6	4	8	5	4	11	6	5	8	6	7	6	8	10
-26	7	5	4	10	6	4	8	5	4	11	6	5	8	6	7	7	8	11
-27	7	5	4	10	6	5	8	5	4	11	6	5	8	6	8	7	8	11
-28	8	5	4	11	7	5	9	5	5	12	7	5	9	7	8	7	9	11
-29	8	6	4	11	7	5	9	6	5	12	7	6	9	7	8	7	9	12
-30	8	6	4	11	7	5	9	6	5	13	7	6	9	7	9	8	9	12
-31	8	6	4	12	7	5	9	6	5	13	7	6	9	7	9	8	9	12
-32	9	6	5	12	8	5	10	6	5	13	8	6	10	7	9	8	10	13
-33	9	6	5	12	8	5	10	6	5	14	8	6	10	8	9	8	10	13
-34	9	7	5	13	8	6	10	7	6	14	8	6	10	8	10	8	10	14
-35	10	7	5	13	8	6	11	7	6	15	8	7	11	8	10	9	11	14
-36	10	7	5	13	8	6	11	7	6	15	8	7	11	8	10	9	11	14
-37	10	7	5	14	9	6	11	7	6	15	9	7	11	9	10	9	11	15
-38	10	7	5	14	9	6	11	7	6	16	9	7	11	9	11	9	11	15
-39	11	7	5	14	9	6	12	7	6	16	9	7	12	9	11	10	12	15
-40	11	8	6	15	9	7	12	8	6	16	9	8	12	9	11	10	12	16
-41	11	8	6	15	10	7	12	8	7	17	10	8	12	9	11	10	13	16
-42	11	8	6	16	10	7	13	8	7	17	10	8	13	10	12	10	13	17
-43	12	8	6	16	10	7	13	8	7	18	10	8	13	10	12	11	13	17
-44	12	8	6	16	10	7	13	8	7	18	10	8	14	10	12	11	13	17
-45	12	8	6	17	11	7	13	9	7	18	10	8	15	10	12	11	13	18
-46	12	9	6	17	11	7	14	9	7	19	11	9	13	10	13	11	14	18
-47	13	9	7	17	11	8	14	9	8	19	11	9	13	11	13	12	14	18
-48	13	9	7	18	11	8	14	9	8	20	11	9	14	11	13	12	14	19
-49	13	9	7	18	11	8	15	9	8	20	11	9	14	11	14	12	15	10
-50	13	9	7	18	12	8	15	10	8	20	12	9	15	11	14	12	15	20

\* Not in stock, only made to order



## Electrical Planning

Supra PLUS must be installed and protected according to local regulations. Due to the structure of parallel connections, the self-regulating heating cable also functions as a possible feed cable for branches and therefore the pipe network can consist of several branches. It is important to note that the total length of the pipe network supplied from one point must not exceed the longest permitted installation length for the heating cable. The longest permitted installation length:

- 100 m for a 10 A fuse
- 150 m for a 16 A fuse

Often it is best to group various short pipes into one circuit. Each circuit must have its own shielding.

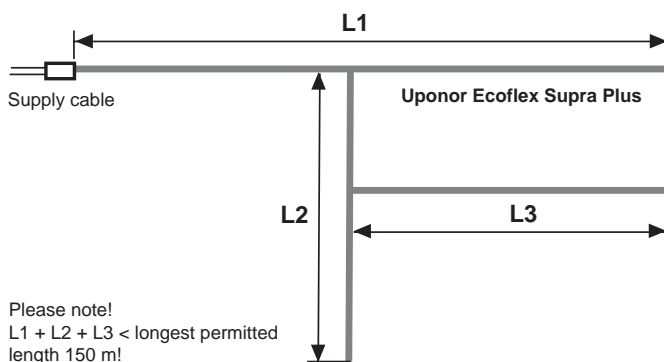

## Circuit length

The lengths of the pipes are summed up and 0.5 m is added for each connection and termination. 1.5 m is added per branch. Also reserve enough cable to wrap around additional sources of thermal loss (valves, feed-troughs, etc.).

## Protection

The total length of the heating cable is used to determine the number and size of safety devices and the number of independent pipe circuits. For example, the piping is 182 m long. The total length including branches and the reservation for connection is 188 m.

The following two cable circuits are selected as examples:

- A)  $(50 + 43 + 30) \text{ m} + (1.5 + 0.5 + 0.5 + 0.5) \text{ m} = 126 \text{ m}$   
a total of 126 m for a safety device of 16 A
- B)  $(43 + 8 + 4 + 4) \text{ m} + (1.5 + 0.5 + 0.5 + 0.5) \text{ m} = 62 \text{ m}$   
a total of 62 m for a safety device of 10 A

If supply cannot be organised from two directions, from different fuse boxes, a ground cable must be installed in the trench for the second supply point when supply is from RK 1. Supply point 2 can also be transferred to point 3 and supply for the circuit can be organised through a centre feed. Use branch tees and supplies by changing one of the branches to a supply cable.

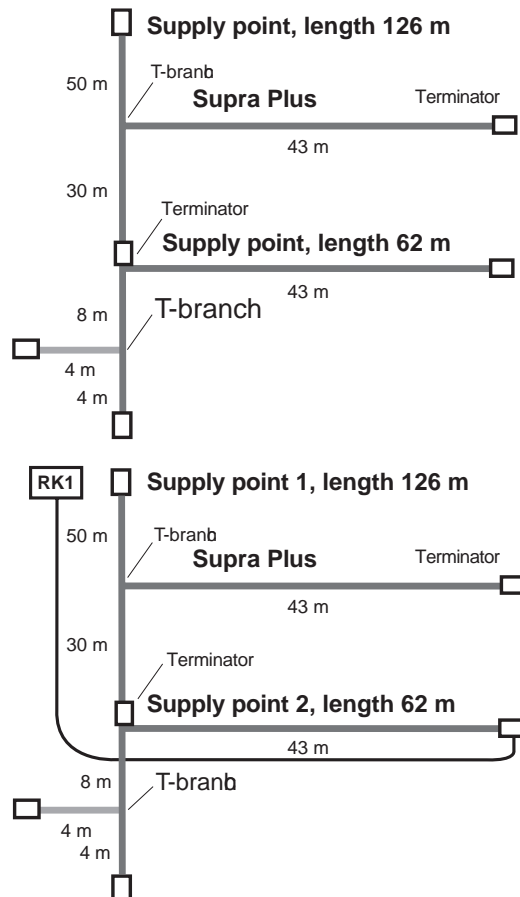

## Example – connection for 450 m pipeline

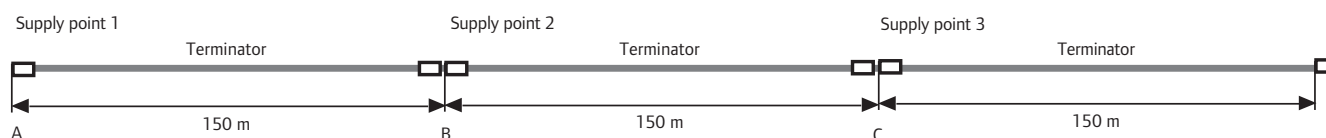

Connection for 450 m pipeline, supply from point A.

The ground cable must be laid in the trench to supply points B and C. The circuits must be kept separate from each other, not protected by the same fuse (in this case 3 x 16 A).

The cable of Supra PLUS pipe is a parallel-fed heating cable. The conductors must not be connected at the cable ends, as this would short circuit the cable.

**The Supra PLUS cable ends (each 150m) needs to be connected with a terminator.**

### Supra PLUS 1

Connection and terminal, control unit, required electrical accessories and end caps.

### Supra PLUS 2

T-branching, required electrical accessories (branching + terminal) and separate T-section insulation sections.

### Supra PLUS 3

Straight extension, required electrical accessories, a PE sleeve and shrink sleeves.

Each package includes detailed installation instructions for the installer and the electrician, and it's important to familiarize with the instructions prior to the installation. The packages do not include the service pipe couplings.

### Overcurrent protection devices

- Plug fuse 10 A or 16 A, slow
- Circuit breakers (automatic) G or K curve
- Residual-current device

The final circuit supplying the heating cable must be protected with a residual current operated device with a tripping current of 30 mA.

## Supply cable dimensioning

The supply cables feeding Supra PLUS pipes must be dimensioned taking account of the general regulations, the ratings of the protection devices and any voltage losses. The cable cross section and structure must be selected and the cable installed in accordance with the regulations, as with any other electrical devices. The cable cross section area must be selected based on the protection device's rated value.

## Control

The heating cable of a Supra PLUS element is controlled with a control unit included in the connection and ending package. The control unit is an electronic regulator designed for controlling the Supra PLUS water pipe equipped with a self-regulating heating cable. It includes a main switch with an indicator light, allowing the cable's power to be switched off. The control unit has two different function modes: thermostat control mode with a temperature sensor, or timer control mode based on a fixed time period. The control method can be selected by lifting the control knob and turning it to the desired setting. The thermostat control mode can be used irrespective if the pipeline has been installed completely underground or above ground. The thermostat controls the cable based on sensor information, which means that the conditions must be the same throughout the entire pipeline length. Use the timer when the conditions vary over the pipeline length. Choose the 'on' periods according to the prevailing conditions.

# Dimensioning

## Pressure loss table for Uponor Ecoflex Supra pipes

Portable water/cooling water pipe: Basis 20 °C water temperature

V	25 / 20.4 / 2.3		32 / 26.2 / 2.9		40 / 32.6 / 3.7		50 / 40.8 / 4.6		63 / 51.4 / 5.8		75 / 61.4 / 6.8		90 / 73.6 / 8.2		110 / 90.0 / 10.0	
l/s	v l/s	Δp bar/ 100 m	v l/s	Δp bar/ 100 m	v l/s	Δp bar/ 100 m	v l/s	Δp bar/ 100 m	v l/s	Δp bar/ 100 m	v l/s	Δp bar/ 100 m	v l/s	Δp bar/ 100 m	v l/s	Δp bar/ 100 m
0.025	0.076	0.0086														
0.0315	0.096	0.0127	0.059	0.0041												
0.04	0.122	0.0189	0.075	0.0061												
0.05	0.153	0.0275	0.094	0.0088	0.060	0.0031										
0.063	0.193	0.0407	0.119	0.0130	0.075	0.0045										
0.08	0.245	0.0611	0.151	0.0195	0.096	0.0067	0.061	0.0024								
0.1	0.306	0.0895	0.188	0.0285	0.120	0.0098	0.076	0.0034								
0.125	0.382	0.1315	0.235	0.0417	0.150	0.0144	0.096	0.0050	0.060	0.0017						
0.16	0.490	0.2016	0.301	0.0638	0.192	0.0219	0.122	0.0076	0.077	0.0026	0.054	0.0011				
0.2	0.612	0.2974	0.377	0.0939	0.240	0.0321	0.153	0.0111	0.096	0.0037	0.068	0.0016				
0.25	0.765	0.4394	0.471	0.1384	0.300	0.0473	0.191	0.0163	0.120	0.0055	0.085	0.0024	0.059	0.0010		
0.315	0.964	0.6599	0.593	0.2072	0.377	0.0706	0.241	0.0244	0.152	0.0082	0.107	0.0036	0.074	0.0015		
0.4	1.224	10.068	0.753	0.3152	0.479	0.1071	0.306	0.0369	0.193	0.0123	0.136	0.0054	0.094	0.0023	0.063	0.0009
0.5	1.530	14.972	0.942	0.4672	0.599	0.1585	0.382	0.0544	0.241	0.0182	0.170	0.0079	0.118	0.0033	0.079	0.0013
0.63	1.927	22.631	1.187	0.7039	0.755	0.2381	0.482	0.0816	0.304	0.0272	0.214	0.0119	0.148	0.0049	0.099	0.0019
0.8	2.448	34.774	1.507	10.776	0.958	0.3634	0.612	0.1242	0.386	0.0413	0.272	0.0180	0.188	0.0075	0.126	0.0029
1.0	3.059	52.062	1.883	16.072	1.198	0.5405	0.765	0.1842	0.482	0.0611	0.340	0.0266	0.235	0.0111	0.157	0.0043
1,25			2.354	24.022	1.498	0.8053	0.956	0.2738	0.602	0.0906	0.425	0.0394	0.294	0.0163	0.196	0.0063
1,6			3.014	37.567	1.917	12.547	1.224	0.4253	0.771	0.1403	0.544	0.0609	0.376	0.0252	0.252	0.0097
2.0					2.396	18.774	1.530	0.6345	0.964	0.2088	0.680	0.0904	0.470	0.0374	0.314	0.0143
2,5					2.995	28.148	1.912	0.9483	1.205	0.3112	0.850	0.1345	0.588	0.0555	0.393	0.0212
3.15							2.409	14.406	1.518	0.4714	1.071	0.2033	0.740	0.0838	0.495	0.0320
4.0							3.059	22.247	1.928	0.7254	1.360	0.3123	0.940	0.1285	0.629	0.0489
5.0									2.410	10.873	1.700	0.4670	1.175	0.1917	0.786	0.0729
6.3									3.036	16.567	2.142	0.7098	1.481	0.2908	0.990	0.1103
8.0											2.720	10.965	1.880	0.4480	1.258	0.1695
10.0											3.399	16.493	2.350	0.6722	1.572	0.2537
12.5													2.938	10.104	1.965	13.804
16.0															2.515	0.5966
20.0															3.144	0.8977

Potable water/cooling water pipe: Basis 20 °C water temperature

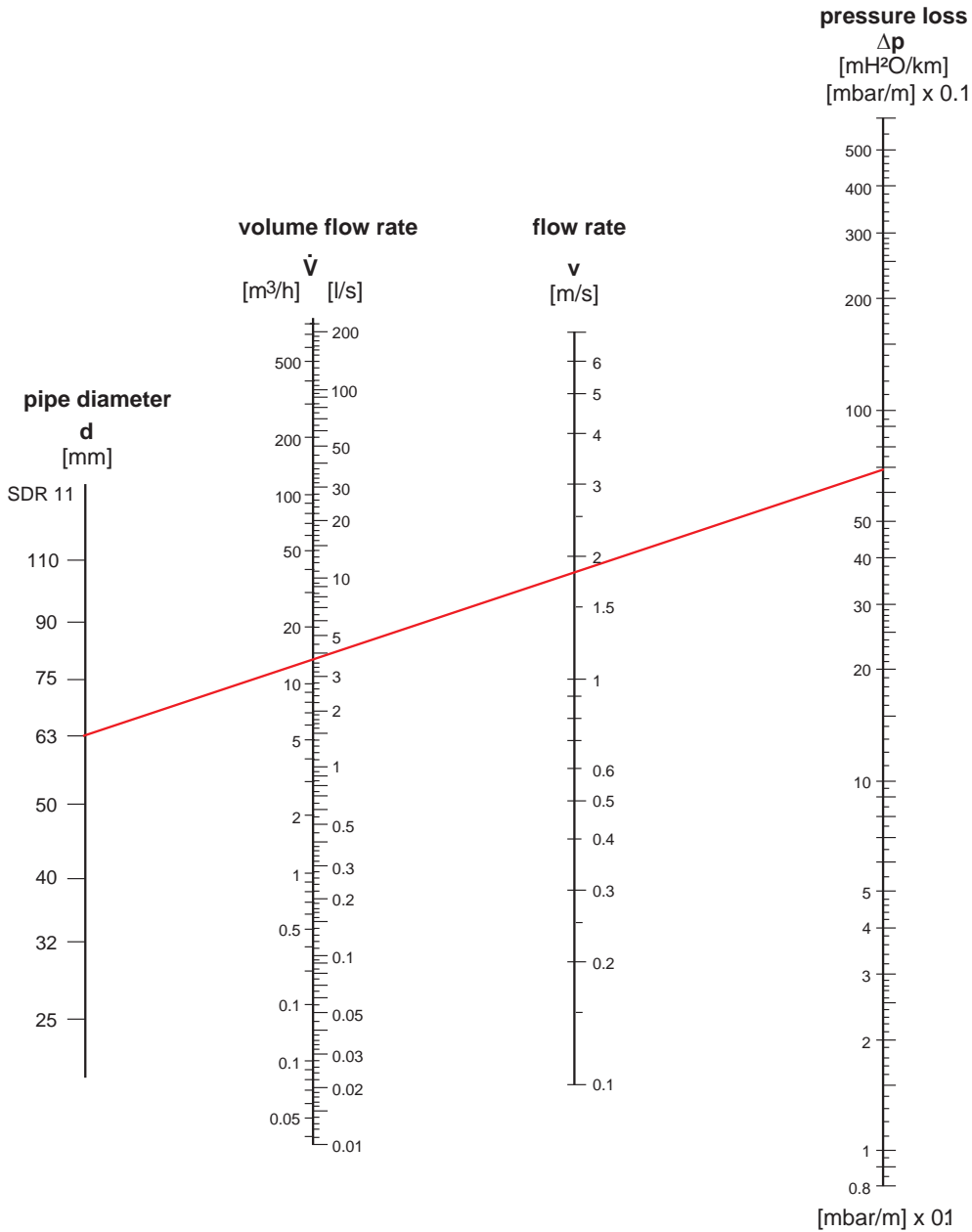

**Example**

**General data:**  $\dot{V} = 3.8$  l/s  
 $v = 1.8$  m/s  
 pipe length = 120 m

**Outcome:**  $d = 63$   
 $\Delta p = 68 \text{ mH}_2\text{O}/1000 * 120 \text{ m}$   
 $= 8.2 \text{ mH}_2\text{O} (0.82 \text{ bar})$

# Installation

## General installation instructions

Uponor Ecoflex Supra PLUS should be dug and covered at the depth of at least 10 – 30 cm. Supra PLUS can withstand continuous freezing and if conditions so require, it can be installed directly on the ground or snow. When installing Supra PLUS freely on the ground, adequate mechanical protection must be ensured and the pipe must be protected from direct contact with sharp stones and tree stumps. If vehicles travel over the Supra PLUS, it must be adequately protected using a casing pipe that can withstand the weight of vehicles running over it.

Supra PLUS can also be installed as an overhead line. It must be supported with adequate holders according to the manufacturer's instructions. The thermal expansion of the service pipe must be taken into account according to the prevailing installation conditions, for example  $\Delta t = 10\text{ }^{\circ}\text{C}$ ,  $l = 100\text{ m} \Rightarrow \Delta l = 18\text{ cm}$ .

When feeding the pipe through structures, Supra PLUS must be protected with, for example, a plastic casing pipe sealed into the structure. When joining service pipes, reserve approximately 0.5 m of free heating cable at the end of each pipe for connections. In locations with extra

thermal loss (flanges, valves, etc.), some heating cables should be wrapped around the part in question to compensate for the larger thermal loss (cables may intersect).

The installation and assembly of Uponor Ecoflex Supra PLUS is not recommended in temperatures below  $-15\text{ }^{\circ}\text{C}$ . Before installation in cold conditions, the coil should be preheated, for example by storing it at room temperature. The installation must be carried out with care, because a pipe placed against the ground is easily frozen. The pressure pipe must be filled with water before the power is switched on to prevent damage to the service pipe. If the tube must be assembled in extremely cold temperatures, it must first be defrosted and bent on a larger coil. When the pipe has warmed up enough at room temperature, it can be wrapped on a smaller coil.

The coil is unwound by first cutting the binders inside the coil. The inner end of the pipe is tied up to the terrain and the coil is unwound by rolling it. The plastic wrapper prevents the coil from unwinding uncontrollably.

When storing the coil in conditions where the open end of the heating cable is susceptible to moisture, the end of the cable must be protected from the moisture.

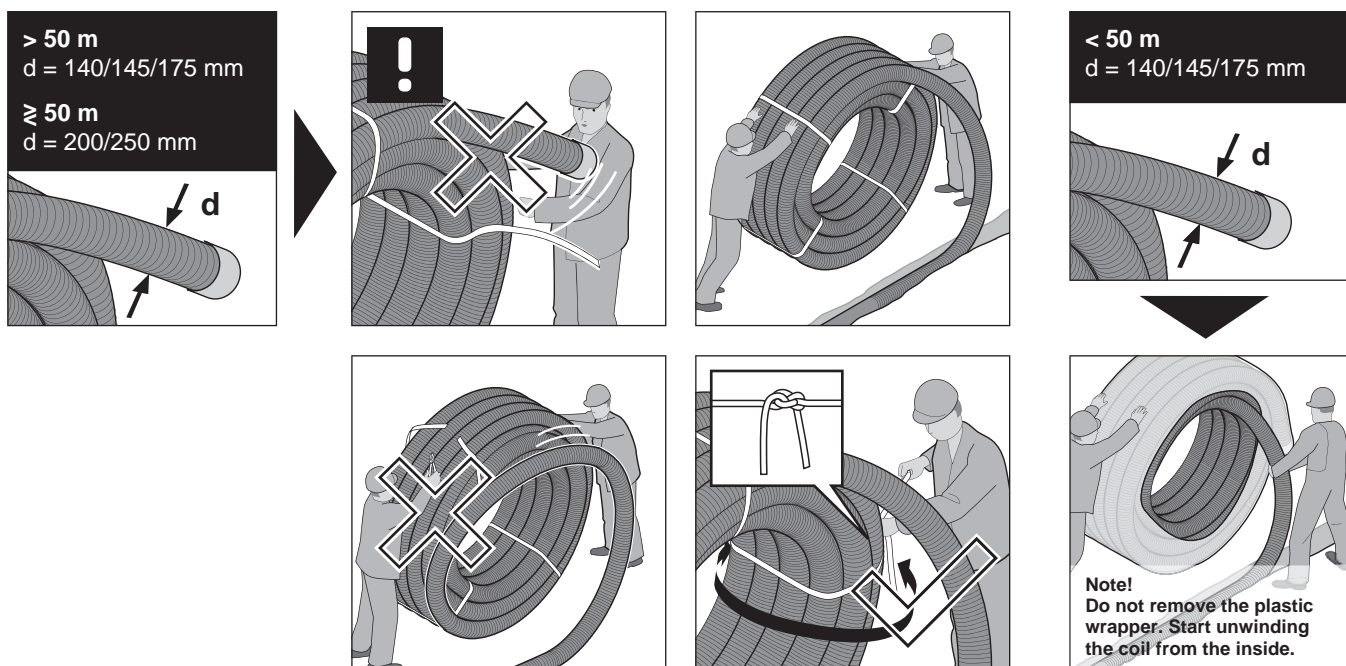



## General electrical installation instructions

### • Installation

General safety regulations must be complied with during the installation. The heating cable can only be connected by a qualified electrician. Do not damage the heating cable during installation!

### • Connections

Besides the heating cable, no other consumption is permitted on the final circuit protected with a residual current operated device. It must be possible to separate the heating cable installation from the network either with a common or circuit specific switch that can also be connected to the control circuit. The switch must bear position indicator markings and a label explaining the installation, for example, "Water pipe non-freeze heating". The network connection takes place through the control unit. The protective earth metal cord on the heating cable must not be used as a neutral conductor. The supply cable must always be equipped with a separate shielded wire in the neutral conductor (General safety regulations).

The insulation resistance of the heating cable must be measured before covering and commissioning the pipes. The measurement is conducted using direct-current voltage 500V – 2.5 kV D/C. The insulation resistance should be  $R > 20 \text{ M}\Omega$ . Connection must be made so that the insulation resistance of the heating cable can be easily measured later in an accessible location.

The extension, tee branching and connection of the heating cable to the supply cable are conducted using approved shrinking plastic couplings. The cables can touch in the joints, because the self-regulating heating cable cannot overheat.

**Please note!** In temperatures of under 0 °C, the resistance of the cable is very small. When switching the cable on in low temperatures, the protection (fuse) may go off. The protection can be altered temporarily in order to increase the cable temperature and resistance and to keep the cable switched on.

### • Technical drawings

The technical drawings must include:

- the type of heating cable
- the number of heating cables
- the placement of heating cables
- the maximum permissible operating temperature for the cable

## Uponor Ecoflex Supra PLUS connection and end set



### Installation of the coupling

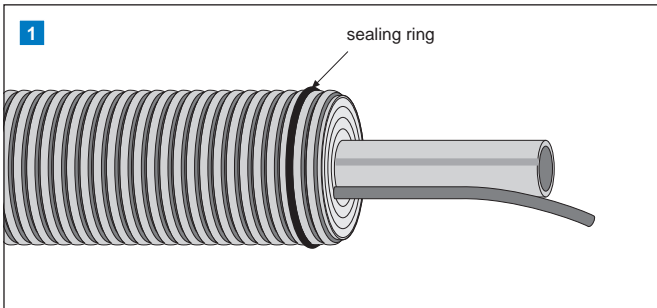

Peel off the casing pipe and remove the insulation taking into account the length of the end cap. Reserve 0.5 m of cable for the electrician. Cut the service pipe at the required length. Do not damage the cable or the service pipe. Clean thoroughly (including the casing pipe).

Place the seal in its place in the 2nd or 3rd groove. Cut the output for the flow pipe of the end cap at the correct dimension. Cut the sensor output (2) and cable output (1) at the correct locations (at the end of the output).

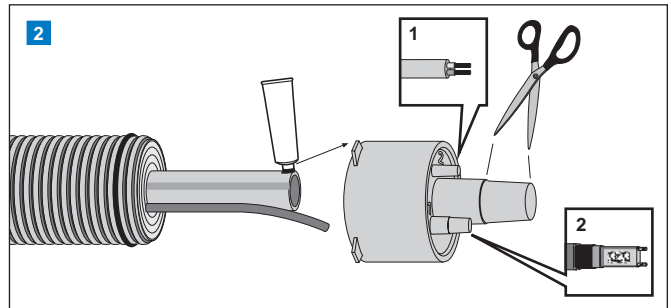

Install the sensor. Pull the end cap on top of the pipe using lubricant.

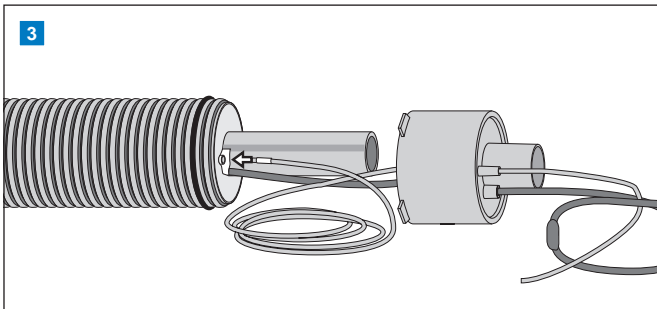

Carry out the extension using the heating cable - supply cable installation set Supra PLUS 1 (separate installation instructions for the electrician).

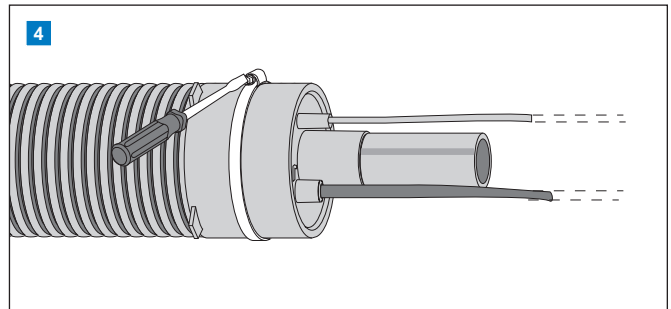

Place the clamping ring above the seal on the end cap and tighten.

## Installation of the terminal

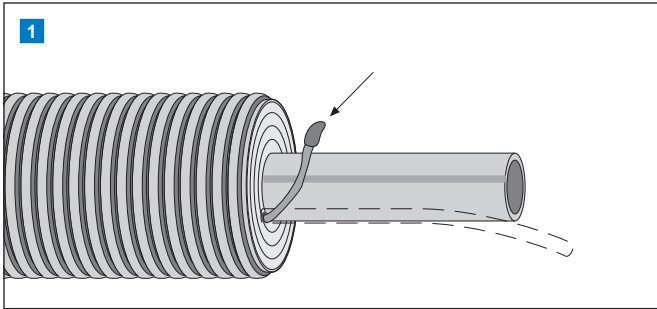

Peel off the casing pipe and remove the insulation taking into account the length of the end cap. Reserve 0.5 m of cable for the electrician. Cut the service pipe at the required length. Do not damage the cable or the service pipe. Clean thoroughly (including the casing pipe).

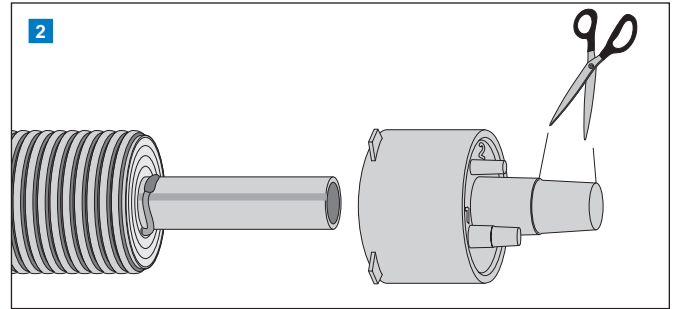

Carry out the termination using the installation set Supra PLUS 1 (separate installation instructions for the electrician).

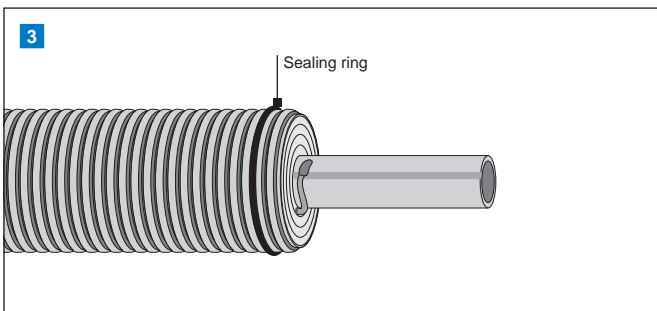

Place the seal in its place in the 2nd or 3rd groove. Cut the output for the service pipe of the end cap at the correct dimension.

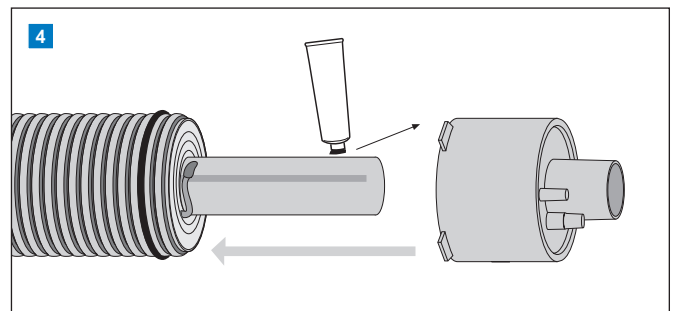

Pull the end cap on top of the pipe element using lubricant.

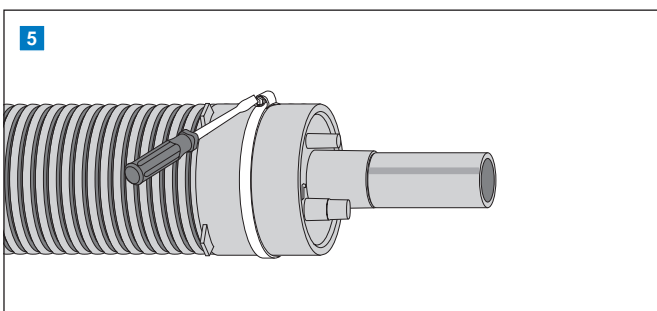

Place the seal in its place in the 2nd or 3rd groove. Cut the output for the service pipe of the end cap at the correct dimension.

## Uponor Ecoflex Supra PLUS T-joint set



### Installation of the branch tee

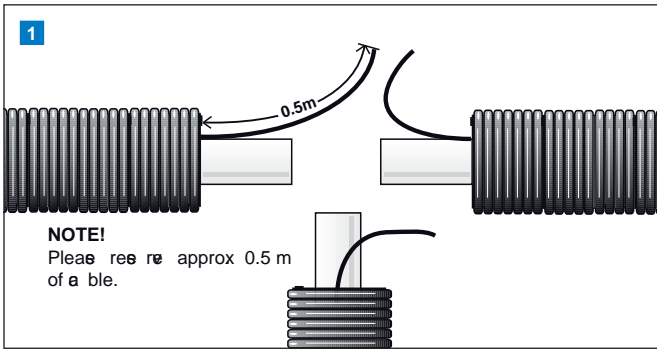

Peel off the casing pipe and remove the insulation taking into account the size of the branch tee. Only peel off what is absolutely required in order to connect the service pipe. Reserve approximately 0.5 m of cable for the electrician. Cut the service pipe at the required length. Please note! Do not damage the cable or the service pipe. Cut the service pipe so that the total length of uninsulated pipe ends and connectors is as small as possible. Thoroughly clean the pipe ends of all burr and dirt (including the casing pipe).

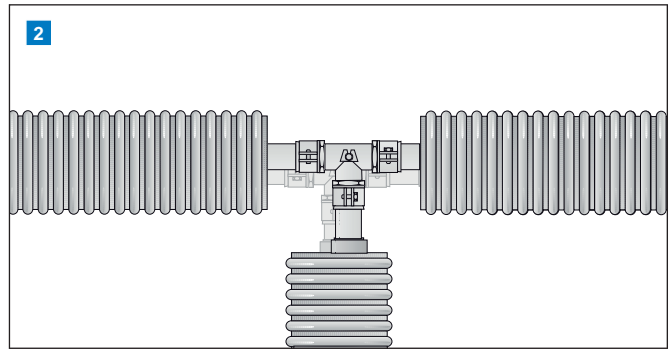

Join the service pipes with couplings (not included in the set). If required, the end caps are installed in place before joining the service pipes. Be careful not to damage the heating cable. Note the required shrinks for insulating the branch tee before installing the fasteners. Use the insulation that was peeled off as an additional insulation for the joint.

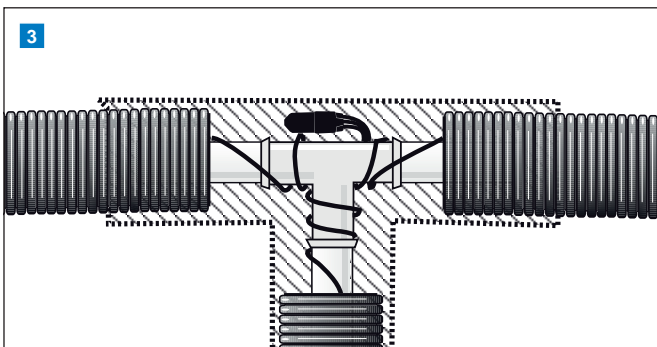

Join the ends of the heating cables with Supra PLUS 2 installation set equipment and wrap the heating cables on the branch with heatproof tape (electrician).

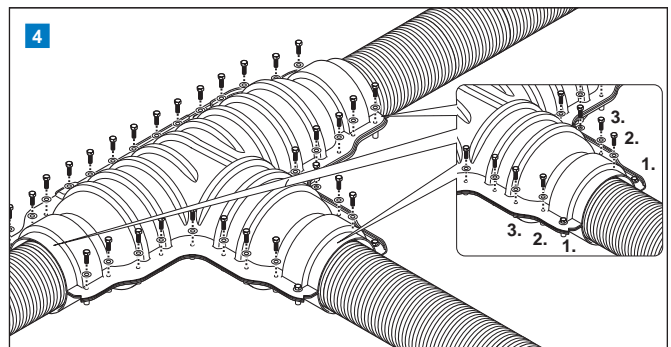

Install insulated T-set according to instructions

## Installation of the branch tee terminal

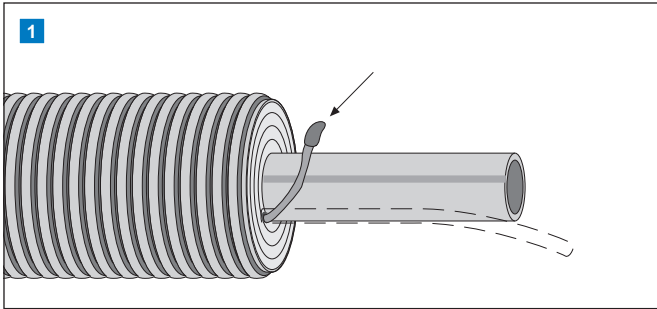

Peel off the casing pipe and remove the insulation taking into account the length of the end cap. Reserve 0.5 metres of cable for the electrician. Cut the service pipe tube at the required length. Do not damage the cable or the flow pipe. Clean thoroughly (including the casing pipe).

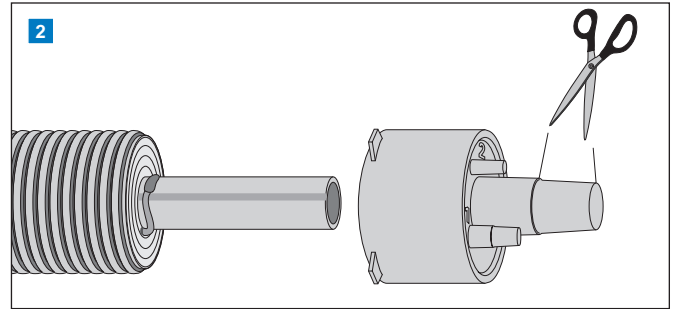

Carry out the termination using the installation set Supra PLUS 2 (separate installation instructions for the electrician).

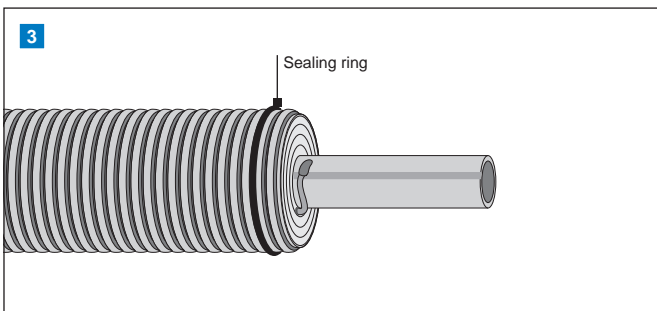

Place the seal in its place in the 2nd or 3rd groove. Cut the output for the service pipe of the end cap at the correct dimension.

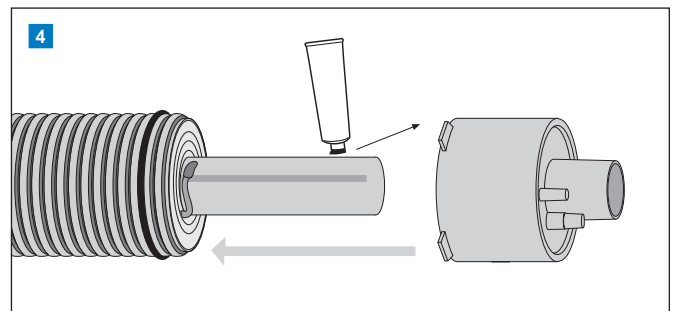

Pull the end cap on top of the pipe element using lubricant.

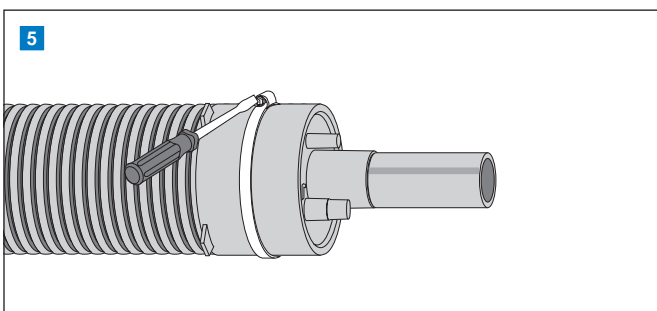

Place the clamping ring above the seal on the end cap and tighten.



## Uponor Ecoflex Supra PLUS straight joint set



### Conducting the extension

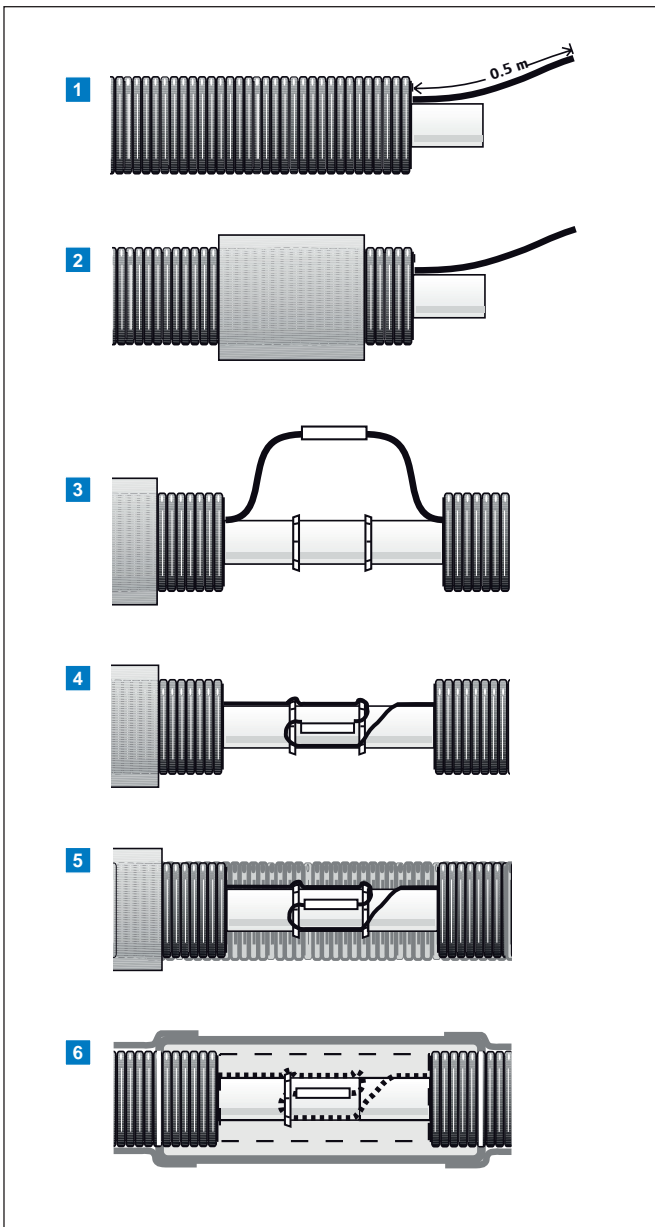

### Note!

Remove the insulation in a way that allows to use it later to insulate the connector. Cut the service pipe at the required length. Do not damage the cable or the service pipe. Cut the service pipe so that the total length of uninsulated pipe ends and fasteners do not exceed the length of the PE sleeve (400 mm). Clean the end of the pipe thoroughly (including the casing pipe).

- 1** Peel off the casing pipe and remove the thermal insulation taking into account the length of the PE sleeve 400 mm. Reserve 0.5 m of cable for the electrician.
- 2** Install the PE sleeve, length 400 mm and shrink sleeves on one pipe before installing the couplings.
- 3** Join the service pipes couplings (not included in the kit). Be careful not to damage the heating cable.

Carry out the extension of the heating cable using the supplies in the installation set Supra PLUS 3 (separate installation instructions for the electrician).

- 5** Fasten the heating cable on the pipe extension using heatproof tape as shown in the picture. There must be no mechanical strain on the heating cable extension.
- 6** Install the insulation that was peeled off carefully on the extension. Fasten using tape.
- 7** Place the PE sleeve on the extension in a central position. Ensure that there is enough shrink sleeve on both casing pipes. Remove any protective paper left inside the shrink sleeve. Shrink using a yellow flame. Start the shrinking from the middle and heat evenly and slowly on all sides. First proceed to one end and then to the other. Be careful not to burn the shrink sleeve or the casing. When the surface of the shrink sleeve is smooth and adhesive is extruding from the ends of the shrink sleeve, the shrink sleeve has received enough warmth. Installation is ready when the extension has cooled down to the ambient temperature.

# Uponor Ecoflex Supra Standard: non-freeze water pipes for longer pipelines

Supra Standard is a versatile insulated water pipe. Regulator-controlled standard resistor heating cable keeps the pipe from freezing. The system can be connected to either 230 V or 400 V voltage. Supra Standard is an economical solution for the installation of long non-freezing water and waste water pipes as well as various industrial fluid pipes in conditions susceptible to freezing. Its power consumption is small, because the surface temperature of the cable is extremely carefully monitored. Thanks to the regulator, the pipe temperature can be retained exactly on the required

level. The Supra Standard pipe is manufactured with two different standard resistor cables with a standard resistance throughout the length of the cable. The yellow cable  $2 \times 0.48 \Omega/m$  is intended for pipe lengths 70-300 m and the white cable  $2 \times 0.05 \Omega/m$  for lengths of 150-700 m. Longer pipelines require several power supply points. Supra Standard is supplied on coil and completely ready for installation. The system contains complete sets for joining, branching and extending a pipe (service pipe couplings are not contained in the sets).

## Pipe design



### 1 HDPE jacket pipe

The HDPE jacket pipe are made of corrugated HD polyethylene. Corrugation makes the casing robust against heavy traffic load but keeps flexibility for the installation.

### 2 Insulation

The insulation is made of crosslinked polyethylene foam. The closed-cell structure of the insulation prevents water absorption and provides good insulation capacity. The foamed plastic density is  $30 \text{ kg/m}^3$  and thermal conductivity  $0.040 \text{ W/mK}$  at  $40 \text{ }^\circ\text{C}$ .

### 3 Heating cable

The heating cable is available in the colours white  $2 \times 0.05 \Omega/m$  and yellow  $2 \times 0.48 \Omega/m$ . Heating cable is constant resistant. Power supply 230 V or 400 V.

### 4 Service pipe PE 80/PE 100

The service pipe has been developed for conveying cold tap water. The service pipes are made of PE 80 (25-63 mm) and PE 100 (75-110 mm).

## Uponor Ecoflex Supra Standard with white cable



20 °C



12.5 or 16 bar



25 – 110 mm

### Main application

- Transport of cold water
- Freeze-protection

### Other applications

- Sewage water

### Medium pipe

- MDPE (PE 80, SDR 11, Dim. 25-63 mm)
- HDPE (PE 100, SDR 11, Dim. 75-110 mm)

### Insulating material

- PE-X

### Material jacket pipe

- HDPE

### Cable

- Constant resistant (0.05 Ω/m)

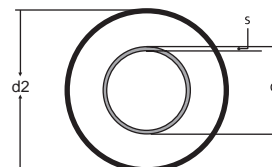

## Uponor Ecoflex Supra Standard with white cable offering

Item no.	Medium pipe d x s [mm]	DN [mm]	Jacket pipe d2 [mm]	Bending radius [m]	Weight [kg/m]	Max. length on delivery [m]
1034231	32 x 2.9	25	68	0.25	0.70	300
1034258	40 x 3.7	32	140	0.30	1.50	200
1034259	50 x 4.6	40	140	0.40	1.70	200
1034260	63 x 5.8	50	140	0.50	2.00	200
1034261	75 x 6.8	65	175	0.60	2.90	150
1034262	90 x 8.2	80	200	1.10	4.40	100
1034234	110 x 10.0	100	200	1.20	5.10	100

### Note!

Make to order items. Please ask for delivery time.

### Uponor Ecoflex Supra Standard with yellow cable

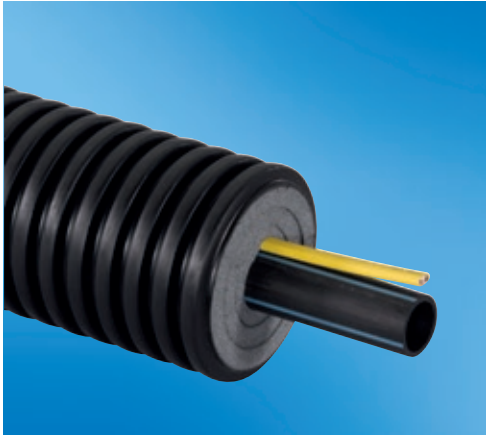

20 °C



12.5 or 16 bar



25 – 110 mm

#### Main application

- Transport of cold water
- Freeze-protection

#### Other applications

- Sewage water

#### Medium pipe

- MDPE (PE 80, SDR 11, Dim. 25-63 mm)
- HDPE (PE 100, SDR 11, Dim. 75-110 mm)

#### Insulating material

- PE-X

#### Material jacket pipe

- HDPE

#### Cable

- Constant resistant (0.48 Ω/m)

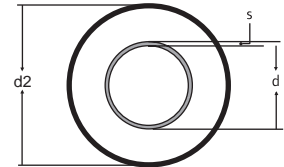

### Uponor Ecoflex Supra Standard with white cable offering

Item no.	Medium pipe d x s [mm]	DN [mm]	Jacket pipe d2 [mm]	Bending radius [m]	Weight [kg/m]	Max. length on delivery [m]
1034214	32 x 2.9	25	68	0.25	0.70	300
1034253	40 x 3.7	32	140	0.30	1.50	200
1034254	50 x 4.6	40	140	0.40	1.70	200
1034255	63 x 5.8	50	140	0.50	2.00	200
1034256	75 x 6.8	65	175	0.60	2.90	150
1034257	90 x 8.2	80	200	1.10	4.40	100
1034222	110 x 10.0	100	200	1.20	5.10	100

#### Note!

Make to order items. Please ask for delivery time.

# Uponor Ecoflex Supra Standard: constant resistant cable and regulator 600S

## The constant resistant cable

The heating power of the constant resistant cable on Supra Standard pipe is controlled using a regulator and an NTC sensor. The temperature sensor attached on the cable surface communicates any heating needs with the regulator and ensures that the cable cannot heat too much even in adverse temperature conditions. This retains the pressure proof qualities of the pipe and the plastic material is not damaged. The regulator switches the power on and off so that the cable surface temperature remains at the set standard value (0 – 30 °C). Thanks to good insulation properties, the share of effective heating periods is approximately 40 % of the total time, providing considerable savings in the consumption of power in comparison with continuous heating. The constant resistant cables of Supra Standard allow supply of electricity from one point to a 700 meter long line.

<b>External dimensions</b>	Width 12 mm, thickness 7 mm
<b>Smallest bending radius</b>	25 mm
<b>Supply voltage</b>	230 V/400 V
<b>The maximum permissible operating temperature</b>	+ 70 °C
<b>Max. installation length</b>	<b>White cable</b> (2 x 0.05 Ω/m + Cu) 400 m/230V or 700 m/400V  <b>Yellow cable</b> (2 x 0.48 Ω/m + Cu) 180 m/230V or 300 m/400V
<b>Nominal output (on the surface of an insulated metal pipe +5 °C)</b>	Max. 25 W/m

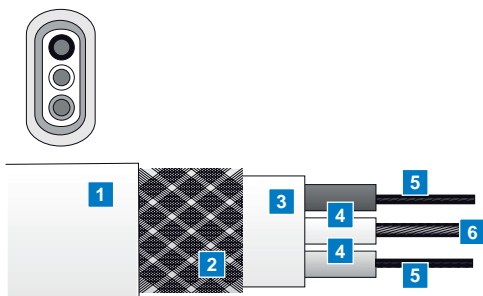

**White cable**  
230 V/400 V, 2 x 0.05 Ω/m (min. 150 m – max. 700 m)

- 1** Outer jacket 0.6 mm PVC
- 2** Copper braid
- 3** Mantle 0.4 mm
- 4** PVC Insulation 0.4 mm
- 5** Resistor wires 0.05 Ω/m
- 6** Copper wire 2.5 mm<sup>2</sup>

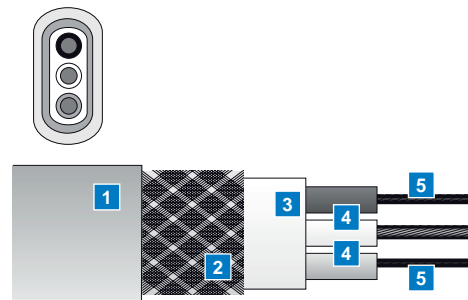

**Yellow cable**  
230 V/400 V, 2 x 0.48 Ω/m (min. 50 m – max. 300 m)

- 1** Outer jacket 0.6 mm PVC
- 2** Copper braid
- 3** Mantle 0.4 mm
- 4** PVC Insulation 0.4 mm
- 5** Resistor wires 0.48 Ω/m
- 6** Copper wire 1.5 mm<sup>2</sup>

### Uponor Ecoflex Supra Standard regulator 600S

Supra Standard regulator 600S is an electrical heating regulator with a continuous time consistent triac regulation. When connecting a power supply to the system, a Supra Standard connection and termination set 1 is always required. It contains the Uponor Ecoflex regulator 600S and an NTC sensor equipped with a 4 m cord. The regulator is supplied in a splash water proof switch box (IP 54) that also functions as the connection box for external cabling. The regulator does not contain the operation switch required for the heating system, meaning that the switch must be separately installed. The regulator allows the maintenance of the cable surface temperature at the set value, reducing power consumption by up to 60 % in comparison with continuously heated cables. Temperature regulation range 0 – 30 °C.



#### Connections

- Supply; fasteners 1 and 2
- Polarity free
- Voltage 200 – 415 V A/C, 50 – 60 Hz with an automatic current selection
- Maximum power 16 A
- Supply through a double-pole switch
- The regulator must always be grounded

#### Uponor Ecoflex Supra Standard regulator 600S

Type designation	Uponor Ecoflex Supra Standard regulator 600S
Rated voltage	230 V/400V
Fan-in	min. 230 W/ 400 W max. 3680 W/ 6400 W
Control temperature	0 to + 30 °C
Indicator lamp light	effective part of the cycle
Installation space requirement	box size 125 x 175 x 75 mm
Housing class	IP 54



## Implementing of Uponor Ecoflex Supra Standard regulator 600S

### Sensor

Connect the sensor wires to fasteners G1 and G3. The sensor has a high potential against the neutral and the ground (>200 V). The sensor installation must be carried out according to existing regulations concerning network installations. The temperature sensor cord may be extended if required (max. 50 m). The sensor can be tested by measuring the circuit resistance. The resistance value of an NTC sensor is approximately 15 kΩ at ±0 °C and approximately 10 kΩ at +30 °C.

### Starting

1. Check the connections.
2. Measure the circuit resistance from between fasteners 3 and 4; 230 V 14.4 Ω < R < 230 Ω; 400 V 25 Ω < R < 400 Ω.
3. Switch on the power and turn the setting to the maximum value. The indicator light turns on or flashes and then burns continuously. Turn the setting to the minimum value. The indicator light turns off or flashes and then turns off completely.

### Troubleshooting

1. Cut off the power and disassemble the sensor connections. Measure the resistance on the sensor and the setting potentiometer. The potentiometer resistance is 0 – 5 kΩ, the sensor resistance is 15 – 10 kΩ (15 kΩ 0 °C and 10 kΩ + 30 °C).
2. Do not connect the sensor and switch on the power. The regulator must supply the heating cable with continuous power and the indicator light must remain lit. Use a hook-on ampere meter to check that the heating cable is receiving power. If the indicator light is not lit and the heating cable is not receiving power, check the regulator supply on the voltage fasteners 1 and 2. If the voltage is correct, the regulator is most likely to be faulty. If the indicator light is lit, but the heating cable is not receiving power, check the resistance on the heating cable. If the resistance is correct, the regulator is most likely to be faulty.

3. Cut off the power and short circuit fasteners G1 and G3. Switch the power on again. The indicator light must be off and no power should be passing through the regulator. Use a hook-on ampere meter to check that the heating cable is not receiving power. If the indicator light is off and the heating cable is not receiving power, the regulator is most likely to be faulty. If the indicator light is lit and fasteners G1 and G3 are short circuited, the regulator is most likely to be faulty.

### Operating principle

The Uponor Ecoflex Supra Standard regulator 600S adapts the average voltage to the prevailing need for voltage steplessly by switching the power on and off in a fixed 60 second pulsating cycle (on + off = 60 seconds). The regulator operates with a zero-current switch (does not cause disturbance in the electric network).

Load	
Smallest functioning	230 W/230 W (1 A) 400 W/400 W (1 A)
The maximum permitted	3680 W/230 W (16 A) 6400 W/400 W (16 A)

Fasteners 3 and 4. Resistive single or dual-phase heater

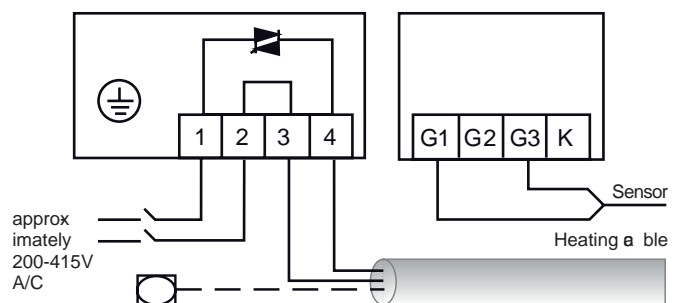

Free voltage conductor, must be protected with a phase sensor

Wiring the supply, heating cable and sensor

# Planning

## Dimensioning and thermal losses

The service pipe is dimensioned according to normal pipe dimensions. Prevailing conditions must be taken into account

when selecting the correct product, for example for ground installations, the temperature of the ground frost, which is approximately -10 °C at the lowest. When installing on pipe bridges, the outdoor temperature and wind chill cause

Temp. outside the pipe 0 °C	Pipe dimensions																		
	25/68	25/90	25/140	32/68	32/90	32/140	40/90	40/140	40/175	50/90	50/140	50/175	63/140	63/175	75/175	75/200	90/175	90/200	110/200
-1	1	1	1	1	1	1	1	1	1	2	1	1	1	1	1	1	2	1	1
-2	1	1	1	2	1	1	1	1	1	2	1	1	2	1	1	1	2	1	2
-3	1	1	1	2	1	1	2	1	1	3	1	1	2	1	2	1	3	2	2
-4	2	1	1	2	2	1	2	1	1	3	2	1	2	2	2	2	3	2	3
-5	2	1	1	3	2	1	2	2	1	4	2	2	3	2	3	2	4	2	3
-6	2	2	1	3	2	2	3	2	1	4	2	2	3	2	3	2	4	3	4
-7	3	2	1	4	2	2	3	2	2	5	3	2	4	3	3	2	5	3	4
-8	3	2	2	4	3	2	4	2	2	5	3	2	4	3	4	3	5	3	5
-9	3	2	2	5	3	2	4	3	2	6	3	2	4	3	4	3	6	4	5
-10	3	2	2	5	3	2	4	3	2	6	3	3	5	3	4	3	6	4	6
-11	4	3	2	5	3	2	5	3	2	7	4	3	5	4	5	4	7	5	6
-12	4	3	2	6	4	3	5	3	3	7	4	3	6	4	5	4	7	5	7
-13	4	3	2	6	4	3	5	3	3	8	4	3	6	4	5	4	8	5	7
-14	5	3	3	7	4	3	6	4	3	8	5	4	6	5	6	4	8	6	8
-15	5	4	3	7	4	3	6	4	3	9	5	4	7	5	6	5	9	6	8
-16	5	4	3	7	5	3	6	4	3	9	5	4	7	5	7	5	9	6	9
-17	6	4	3	8	5	4	7	4	4	10	6	4	8	5	7	5	10	7	9
-18	6	4	3	8	5	4	7	5	4	10	6	4	8	6	7	6	10	7	10
-19	6	4	3	9	6	4	7	5	4	11	6	5	8	6	8	6	11	7	10
-20	6	5	3	9	6	4	8	5	4	11	6	5	9	6	8	6	11	8	11
-21	7	5	4	10	6	4	8	5	4	12	7	5	9	7	8	6	12	8	11
-22	7	5	4	10	6	5	8	5	4	13	7	5	10	7	9	7	12	8	12
-23	7	5	4	10	7	5	9	6	5	13	7	6	10	7	9	7	13	9	12
-24	8	5	4	11	7	5	9	6	5	14	8	6	10	7	9	7	13	9	13
-25	8	6	4	11	7	5	9	6	5	14	8	6	11	8	10	7	14	9	13
-26	8	6	4	12	7	5	10	6	5	15	8	6	11	8	10	8	14	10	14
-27	8	6	5	12	8	5	10	7	5	15	8	6	12	8	10	8	15	10	14
-28	9	6	5	12	8	6	11	7	6	16	9	7	12	9	11	8	15	10	15
-29	9	6	5	13	8	6	11	7	6	16	9	7	12	9	11	9	16	11	15
-30	9	7	5	13	8	6	11	7	6	17	9	7	13	9	12	9	16	11	16
-31	10	7	5	14	9	6	12	8	6	17	10	7	13	9	12	9	17	12	16
-32	10	7	5	14	9	6	12	8	6	18	10	8	14	10	12	9	17	12	17
-33	10	7	6	14	9	7	12	8	6	18	10	8	14	10	13	10	18	12	17
-34	10	7	6	15	10	7	13	8	7	19	10	8	14	10	13	10	18	13	18
-35	11	8	6	15	10	7	13	8	7	19	11	8	15	11	13	10	19	13	18
-36	11	8	6	16	10	7	13	9	7	20	11	9	15	11	14	10	19	13	19
-37	11	8	6	16	10	7	14	9	7	20	11	9	16	11	14	11	20	14	19
-38	12	8	6	17	11	8	14	9	7	21	12	9	16	11	14	11	20	14	20
-39	12	9	6	17	11	8	14	9	8	21	12	9	16	12	15	11	21	14	20
-40	12	9	7	17	11	8	15	10	8	22	12	9	17	12	15	12	21	15	21
-41	12	9	7	18	11	8	15	10	8	22	12	10	17	12	16	12	22	15	21
-42	13	9	7	18	12	8	15	10	8	23	13	10	18	13	16	12	22	15	22
-43	13	9	7	19	12	8	16	10	8	23	13	10	18	13	16	12	23	16	22
-44	13	10	7	19	12	9	16	10	9	24	13	10	19	13	17	13	23	16	23
-45	14	10	7	19	12	9	16	11	9	25	14	11	19	13	17	13	24	16	23
-46	14	10	8	20	13	9	17	11	9	25	14	11	19	14	17	13	24	17	24
-47	14	10	8	20	13	9	17	11	9	26	14	11	20	14	18	14	25	17	24
-48	14	10	8	21	13	9	18	11	9	26	14	11	20	14	18	14	25	17	25
-49	15	11	8	21	13	10	18	12	9	27	15	11	21	15	18	14	26	18	25
-50	15	11	9	21	14	10	18	12	10	27	15	12	21	15	19	14	26	18	26

Uponor Ecoflex Supra Standard is supplied upon order.

significantly more demanding conditions. The adjacent chart shows the Supra Standard thermal losses at various outdoor temperatures.

The inside temperature of the pipe has been assumed to be 2 °C. Read the prevailing outdoor temperature on the first column and select the dimensions of the product on the top row. The chart shows the W/m value required for the pipe to remain unfrozen. Find a suitable connection option in the power curve with the voltage being 230 V or 400 V.

### Example

A pipeline with a total length of 120 m and dimensions 32/90 is installed on a pipe bridge outside in a location susceptible to wind chill, where the dimensioning temperature must be – 50 °C. The required power is then 14 W/m. Connection voltage is selected at 230 V and cable 2 x 0.48 W/m (yellow cable). By connecting 2 x 0.48 W/m in parallel + Cu-return achieves a power of 15 W/m.

## Electrical Planning

The system must be installed and protected according to valid electrical safety regulations. In order to ease planning and use, each circuit must only have one cable type connected to it. Due to the structure of parallel connections, the heating cable also functions as a possible feed cable for branches and therefore the pipe network can consist of several branches. An installation plan and technical drawings must be drawn for all heating cable installations.

Plans are drawn by a qualified electrical planner or contractor according to the manufacturer's instructions. The technical drawing must include the following information: the type of heating cable, its capacity, length, placement in the heated location, the number of heating cables in the installation location and the length and type of the supply cable.

### Circuit length

The lengths of the pipes are added up. Add 0.5 m for both connection and termination and 1.5 m for each branching. Also add enough cable to wrap around additional sources of thermal loss (valves, feed-throughs, etc.). In extensive networks, lines should be grouped in suitable connection circuits so that the cable provides the required output per meter W/m (see the heating power charts with different options for connection). Different connection circuits can be controlled

using the same regulator if the total output does not exceed the maximum load capacity  $P = 6,400 \text{ W}$ . When controlling several different control circuits, the sensor is installed on one circuit. All circuits are then controlled based on the information provided by the sensor. The adequacy of the power must be taken into account for all circuits, if the temperature varies considerably from one circuit to the next.

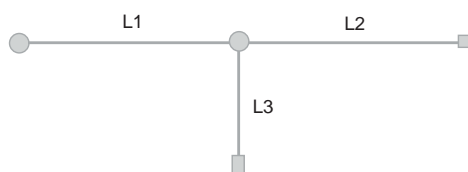

### NOTE!

$L1 + L2 + L3 + 1.5 \text{ m} + 0.5 \text{ m} = L$ , circuit length used to determine the correct connection option.

## Protection

The total length of the pipeline determines the number of independent connection circuits, the number of safety devices and their dimensioning. Protection takes place using a plug fuse 10 A or 16 A, a line protection switch (automatic fuse) G or K curve and residual current operated device 30 mA, also suitable for use as the residual current operated device on pipelines containing flammable fluids.

## Supra Standard connection parts

The Supra Standard system contains complete connection sets for the connection, branching and extension of pipes. The sets do not contain connectors for the service pipes.

### Connection and termination

- Uponor Ecoflex Supra Standard regulator 600S + sensor
- The required electrical parts
- End caps

### T-branch and termination

- Branch tee insulation chute
- The required electrical parts

### **Straight extension**

- The required electrical parts
- Shrink sleeves
- PE sleeve

Each set contains detailed installation instructions for the installer and electrician. Read the instructions carefully prior to the installation.

### **Dimensioning the supply cable**

Supply cables for Uponor Ecoflex Supra Standard pipes must be dimensioned taking into account general regulations, the dimensioning of the safety devices and possible voltage drops. The selection and installation of the cable cross section and structure must be carried out according to regulations, as it is done with all other electrical equipment. The cable cross section must be selected according to the rated voltage of the safety device.

### **Controls**

The Supra Standard is always controlled using the Uponor Ecoflex regulator 600S and an NTC sensor.

### **Operation, maintenance and pipeline repairs**

The maximum permitted operation temperature of the heating cable must not be exceeded, continuous 70 °C. The heating cable does not require maintenance. The heating cable must be switched off and protected from mechanical damage during any repairs to the pipeline. After repairs, a new test log must be filled in.

# Installation

## General installation instructions

Uponor Ecoflex Supra Standard should be installed in the ground at the depth of at least 10-30 cm, if conditions permit. The preliminary filling of the dug-out (around the pipe) must be completed with fine sand in order to prevent damage to the jacket pipe. A careful preliminary fill allows the pipe to withstand above-ground loading. If vehicles travel over the pipeline, it must be adequately protected using a jacket pipe or a concrete slab which can withstand the weight of vehicles running over. Before the pipeline is covered, circuit resistance and insulation resistance must be measured on the cable and they must be recorded in the test log (enclosed).

Supra Standard withstands freezing. It can be installed directly on the ground or snow. When installing the pipe freely on the ground, adequate mechanical protection must be ensured and the pipe must be protected from sharp rocks and tree stumps. When installing on a pipe bridge or shelf, it must be supported with holders in a case-specific manner.

The thermal expansion of the service pipe must be taken into account according to the prevailing conditions, e.g.  $\Delta t$  10 °C,  $l$  = 100 m  $\Rightarrow \Delta l$  18 cm. The service pipe must be anchored at the joints if no thermal movement is required to take place.

When feeding the pipe through structures, Supra Standard must be protected with a proper feed-through element, e.g. a plastic casing pipe sealed into the structure. The installation and assembly of Supra Standard is not recommended in temperatures below -15 °C. Before installation in cold conditions, the coil should be preheated by storing it at room temperature. The installation must always be carried out with care, since a pipe placed against the ground is easily frozen. The pressure pipe must be filled with water before the power is switched on to prevent damage to the service pipe. If the pipe has to be assembled in extremely cold temperatures, it must first be defrosted and bent on a larger coil. When the pipe has warmed up enough at room temperature, it can be wound on a smaller coil.

The installation of the sensor on the cable surface must be taken into account in the pipe installation phase, see chapter Installation of the sensor. The sensor cord can be extended to 50 m.

Jacket pipe dimensions [mm]	Maximum support interval [m]
68	0.6
90	0.9
140	1.2
175	1.8
200	2.2

Maximum support intervals for different jacket pipe diameters in horizontal and vertical mounting. If required, the support interval can be shortened to prevent "hanging".

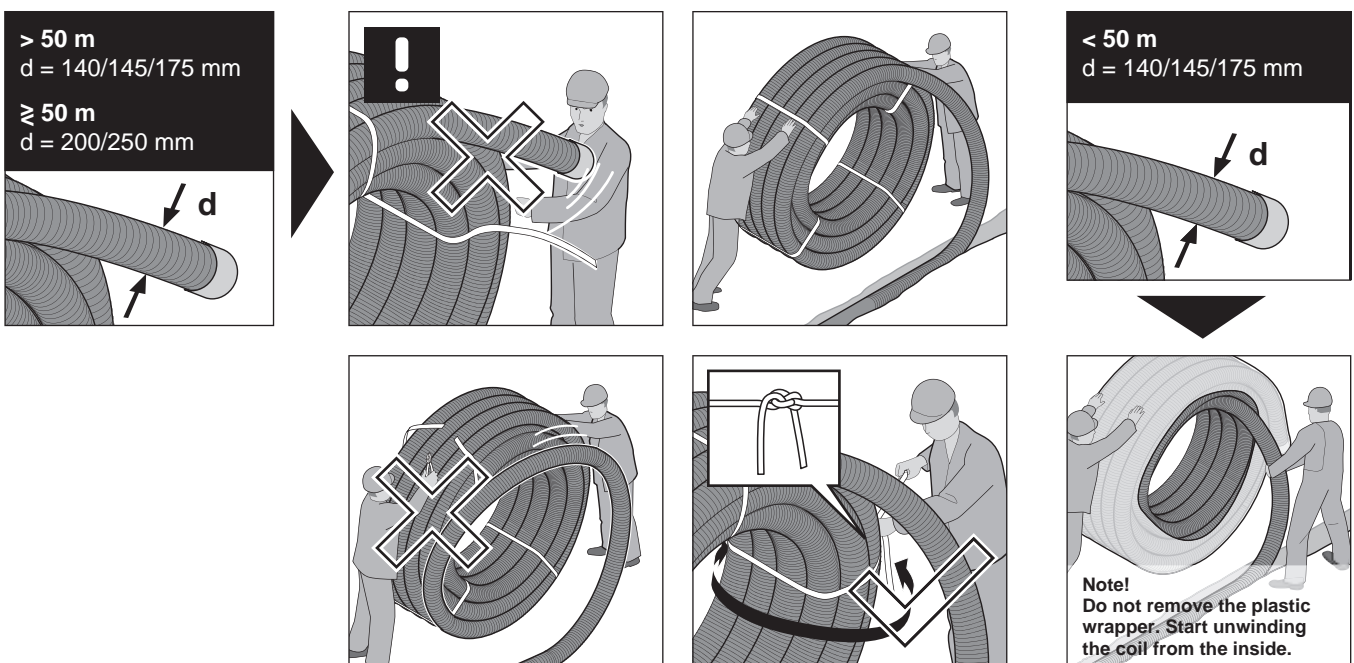

## Electrical Installation

General safety regulations must be considered during the installation. Connections can only be made by a qualified electrician. The heating cable must not be damaged during installation. The heating cable and its connection box must usually be placed on a class A structure so that, in normal use, they do not cause a temperature higher than 80 °C in combustible construction materials or a temperature higher than 175 °C when a fault occurs. In order to compensate for additional thermal loss, some heating cable is wrapped around flanges, metal connectors, valves etc. making sure that the cables do not touch. After installation, there must not be any tensile stress on the cable. Please take into consideration the  $\Delta l$  caused by the temperature of the plastic pipe in cable connections.

### Connections

The Uponor Ecoflex Supra Standard regulator 600S is always connected to a final circuit protected with a residual current operated device. Besides the heating cable, no other consumption is permitted on the final circuit. It must be possible to separate the heating cable installation either with a common or circuit specific switch that can also be connected to the control circuit. The switch must bear position indicator markings or an indicator light and a label explaining the installation, for example, "Water pipe non-freeze heating". The operation switch is not included in the delivery. The correct connection option must be checked from the cable length/ capacity chart and connection diagram (see next pages). The connection must be made so that the insulation resistance and the cable loop resistance can be easily measured later in an accessible location. Some connection options leave a free active conductor for

the regulator because all three conductors, the resistor conductors and the Cu-return conductor are connected at the end of the cable. The free active conductor must always be equipped with the cap included in the delivery. The design length of the heating cable must not be altered without the planner's permission. An earthed metal cord must always be connected to a (PE) protective earth terminal. The metal cord must not be used as a neutral conductor. The supply cable must always be equipped with a separate shielded wire in the neutral conductor (general safety regulations). Instructions contained in the connection sets must be complied with. The insulation and circuit resistance of the heating cable must be measured before covering and commissioning the pipes. The insulation level must comply with the requirement 1 k $\Omega$ /1 V (general safety regulations).

During measuring, the test log supplied with the installation set must be filled in. The appropriately filled in test log is a prerequisite for safe operation.



## Cable connection options

### Connection instructions for the yellow heating cable

Cable type  
2 x 0.48 Ω/m + 1.5 mm<sup>2</sup> Cu-return

All tables:  
MU = black  
RU = brown  
VA = white

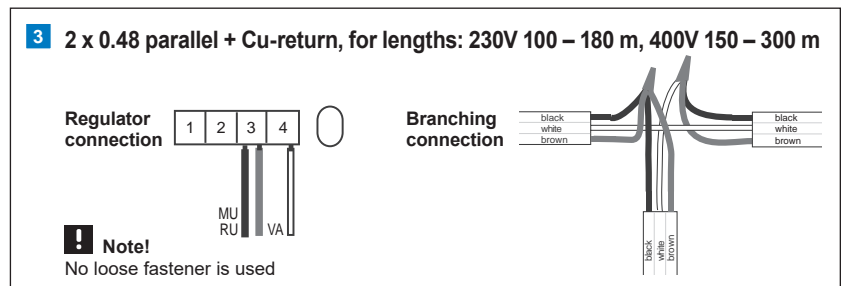
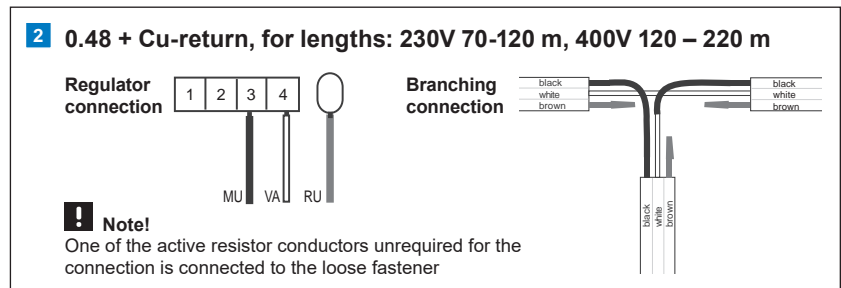
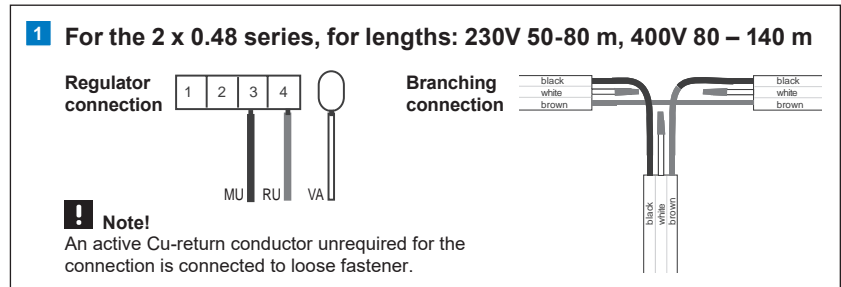

### Connection instructions for the white heating cable

Cable type  
2 x 0.05 Ω/m + 2.5 mm<sup>2</sup> Cu-return

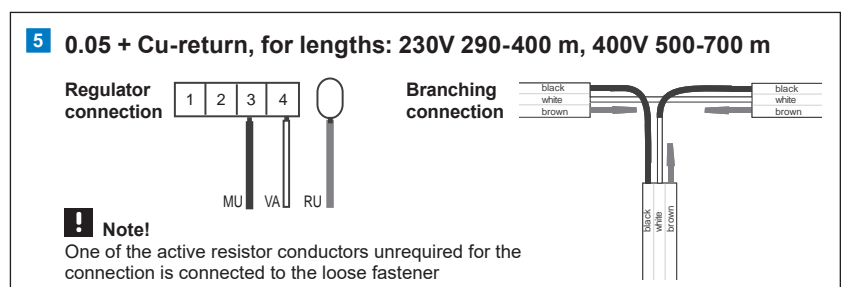
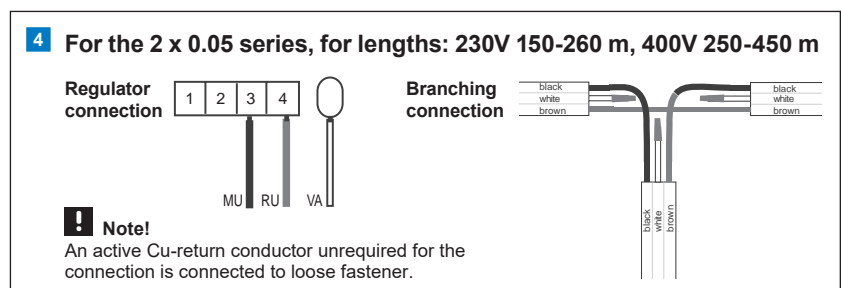

## Heating capacity charts with various options for connections

### Yellow cable

#### Yellow cable 2 x 0.48 Ω/m + Cu, connection 230 V

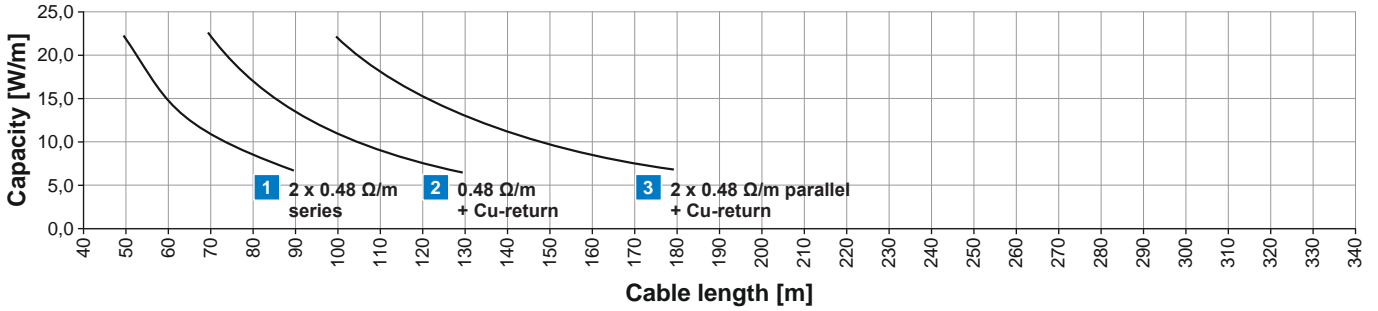

#### Yellow cable 2 x 0.48 Ω/m + Cu, connection 400 V

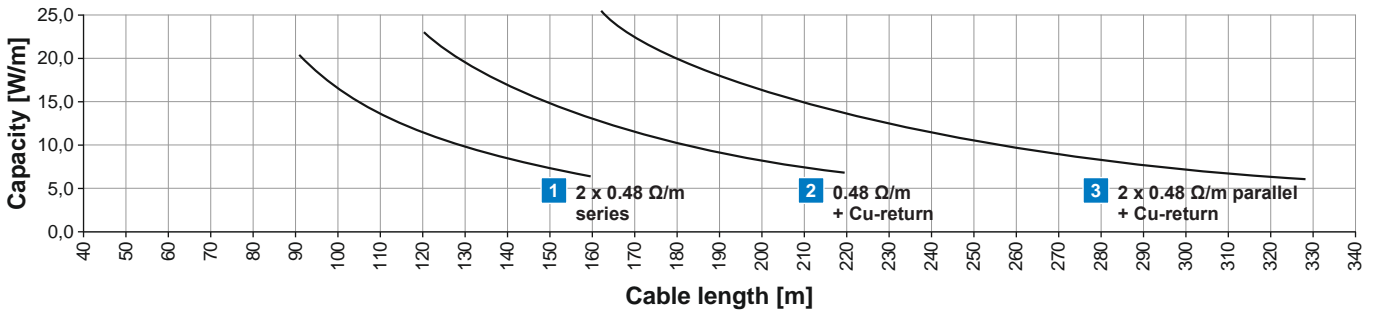

### White cable

#### White cable 2 x 0.05 Ω/m + Cu, connection 230 V

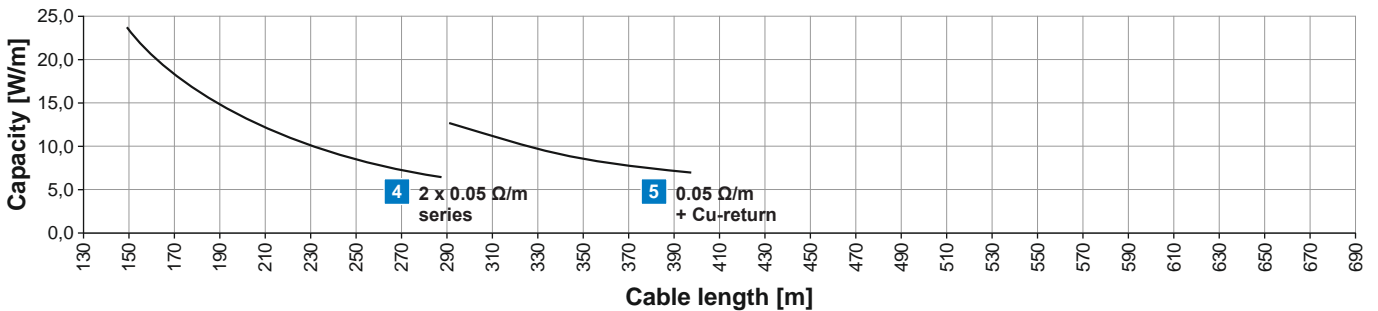

#### White cable 2 x 0.05 Ω/m + Cu, connection 400 V

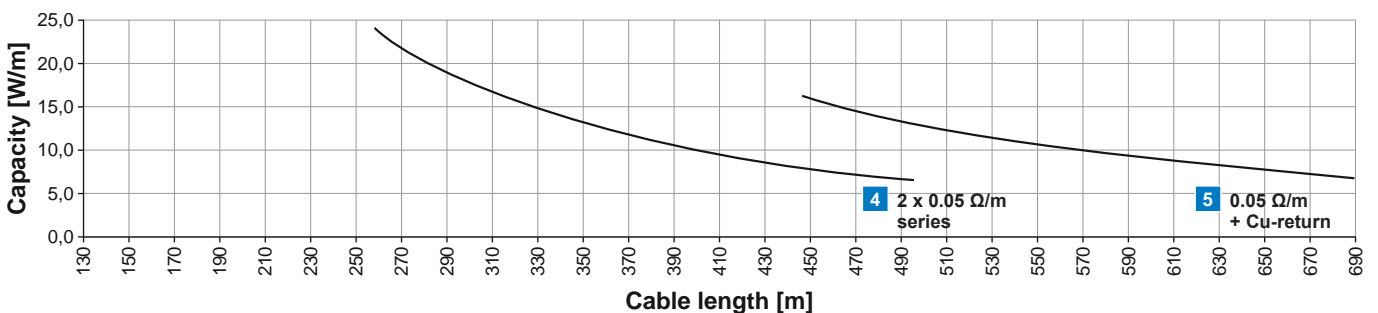

## Installing the regulator

The Uponor Ecoflex Supra Standard regulator 600S is supplied in a splash water proof switch box (IP 54) installed on the surface of the structure and also functioning as the connection box for external cabling. The indicator lamp indicates the supply of electrical power. The fuse inside the regulator is a fast 5 A sand-filled glass-tube fuse. The regulator is supplied with an NTC temperature sensor equipped with a 4 m cord. The temperature sensor cord may be extended if required (max. 50 m). The sensor can be tested by measuring the circuit resistance. The resistance value of an NTC sensor is approximately 15 k $\Omega$  at  $\pm 0$  °C and approximately 10 k $\Omega$  at +30 °C. The NTC temperature sensor is attached on the heating cable surface (please see image) The temperature sensor cable is protected with a casing in locations where it is susceptible to mechanical damage.

The regulator does not contain the operation switch required for the heating system, meaning that the switch must be separately installed. The regulator is connected to a final circuit protected with a 30 mA ground fault interrupter (on longer lines, a 300 mA ground fault interrupter may be used instead). The temperature in the regulator installation location must be room temperature or lower.

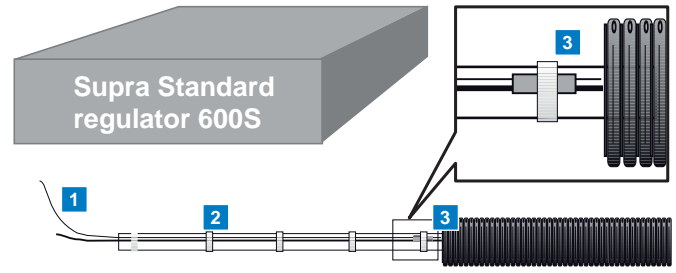

*The regulator is connected to a final circuit protected with 30 mA ground fault interrupter*

- 1 Sensor cord
- 2 Tape

- 3 Sensor

## Uponor Ecoflex Supra Standard connection and end set



### Installation of the sensor

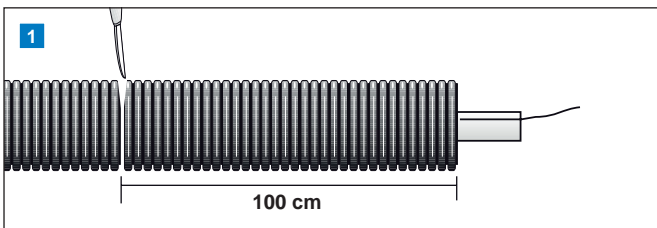

Cut the casing pipe and insulation with a sharp knife one metre from the end of the pipe. Do not press the knife all the way through the insulation to avoid damaging the cable.

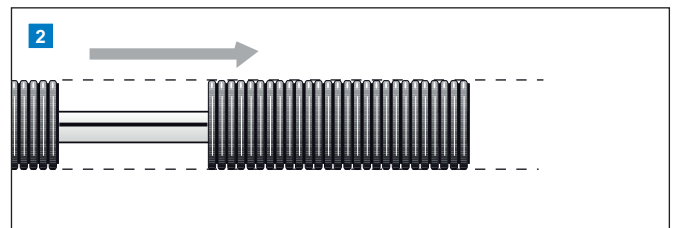

Pull the cut casing pipe and insulation off the service pipe.

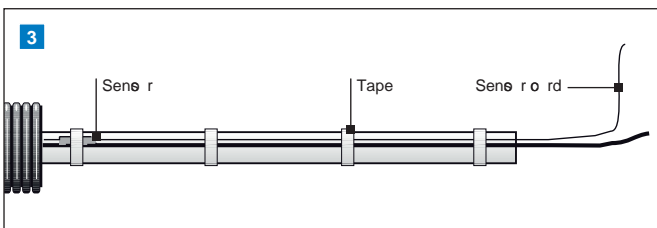

Attach the temperature sensor on the heating cable surface according to the electrical installation instructions supplied in Supra Standard 1 installation set and tape the sensor cord on the pipe.

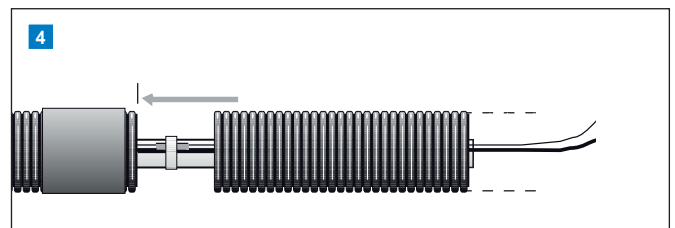

Place the peeled off insulation back in its place. Put a shrinking plastic pipe on the extension and heat it up.

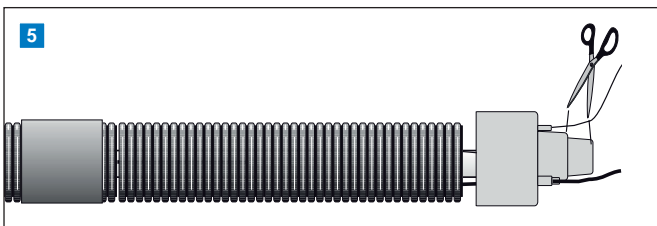

Place the seal in its place 2. at the 2nd or 3rd groove. Cut the output for the service pipe of the end cap at the correct dimension. Cut the sensor output (2) and cable output (1) at the correct location.

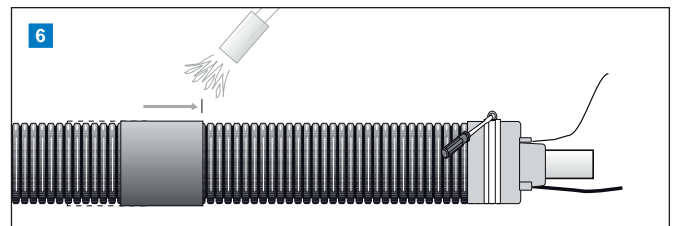

Fit the end cap in place. Join the heating cable with the supply cable using Supra Standard 1 installation set (separate installation instructions for the electrician). Place the clamping ring above the o-ring on the end cap and tighten.

## Installation of the terminal

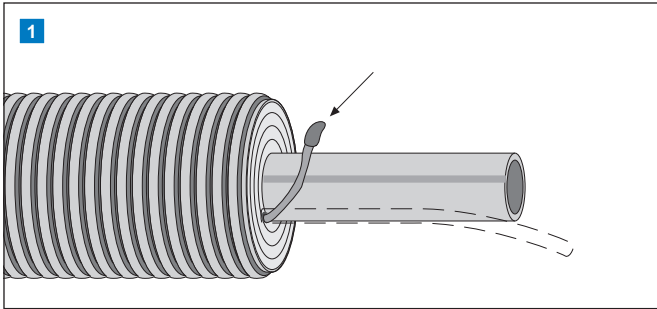

Peel off the casing pipe and remove the insulation taking into account the length of the end cap. Reserve 0.5 m of cable for the electrician. Cut the service pipe at the required length. Do not damage the cable or the service pipe. Clean thoroughly (including the casing pipe).

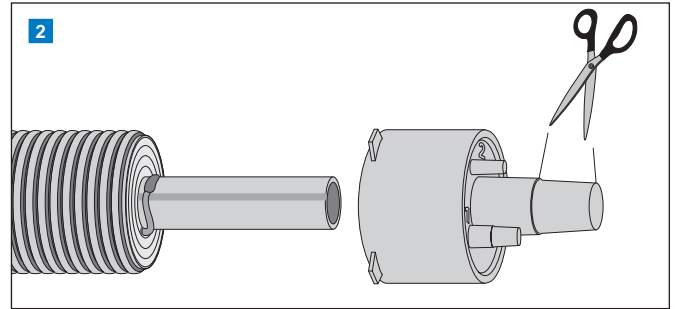

Carry out the termination using the installation set Supra Standard 1 (separate installation instructions for the electrician).

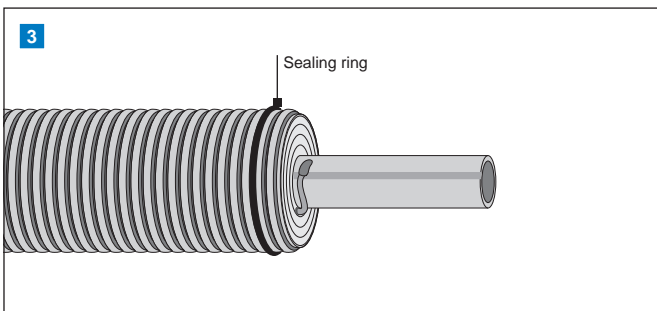

Place the seal in its place in the 2nd or 3rd groove. Cut the output for the service pipe of the end cap at the correct dimension.

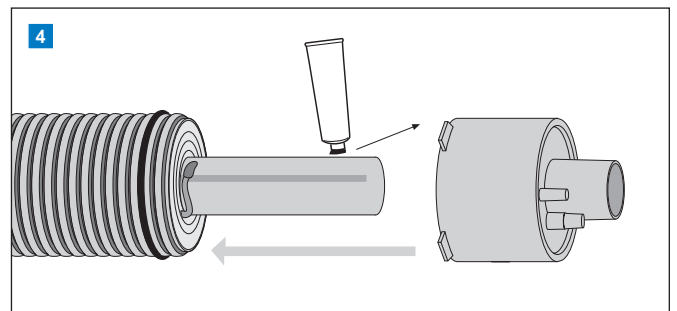

Pull the end cap on top of the pipe element using lubricant.

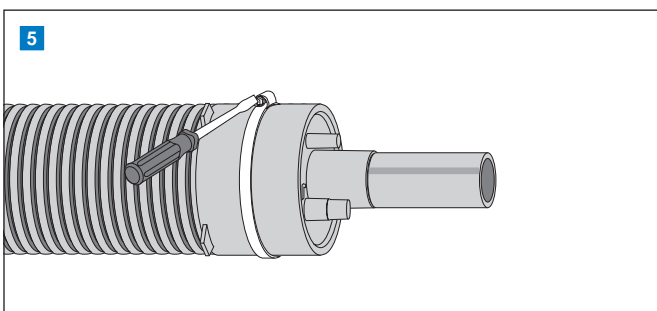

Place the clamping ring above the seal on the end cap and tighten.

Uponor Ecoflex tee insulation set plus Supra Standard cable set S2



Installation of the branch tee

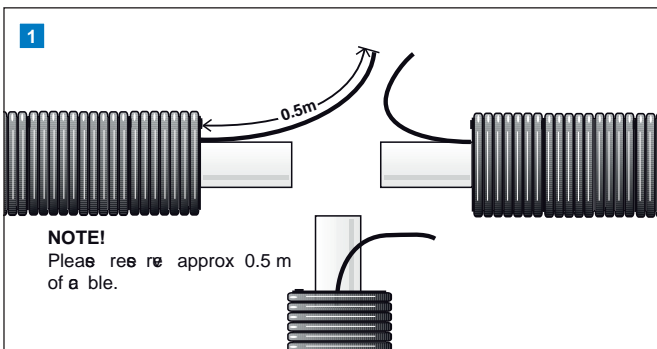

Peel off the casing pipe and remove the insulation taking into account the size of the branch tee. Only peel off what is absolutely required in order to connect the service pipe. Reserve approximately 0.5 m of cable for the electrician. Cut the service pipe at the required length. Please note! Do not damage the cable or the service pipe. Cut the service pipe so that the total length of uninsulated pipe ends and connectors is as small as possible. Thoroughly clean the pipe ends of all burr and dirt (including the casing pipe).

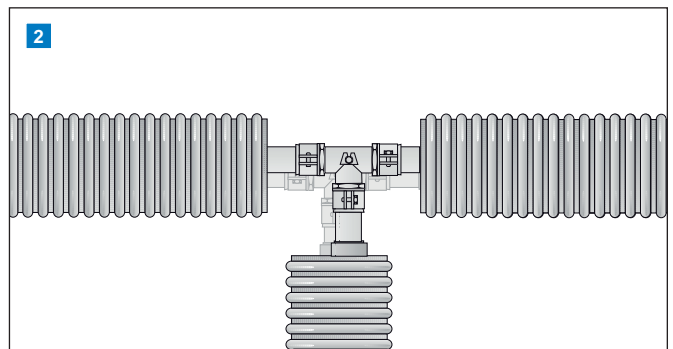

Join the service pipes with couplings (not included in the set). If required, the end caps are installed in place before joining the service pipes. Be careful not to damage the heating cable. Note the required shrinks for insulating the branch tee before installing the fasteners. Use the insulation that was peeled off as an additional insulation for the joint.

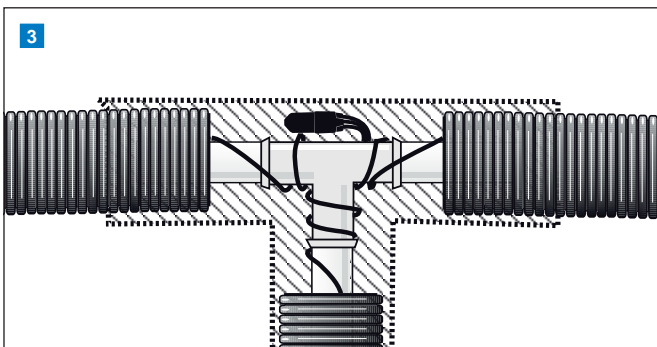

Join the ends of the heating cables with Supra Standard 2 installation set equipment and wrap the heating cables on the branch with heatproof tape (electrician).

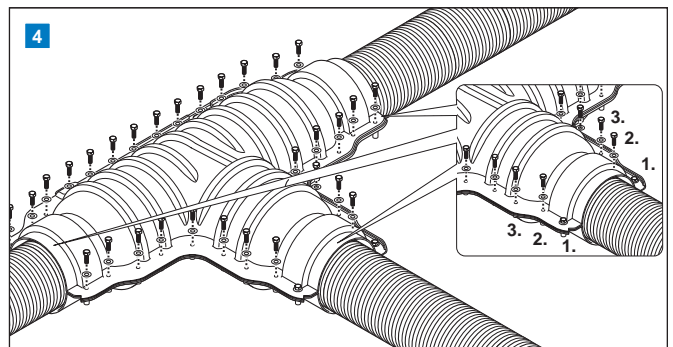

Install insulated T-set according to instructions



## Installation of the terminal

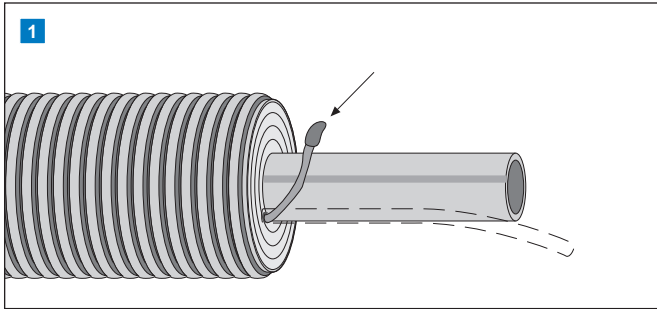

Peel off the casing pipe and remove the insulation taking into account the length of the end cap. Reserve 0.5 m of cable for the electrician. Cut the service pipe at the required length. Do not damage the cable or the service pipe. Clean thoroughly (including the casing pipe).

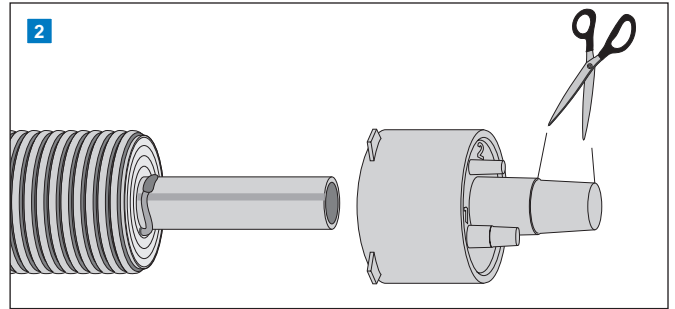

Carry out the termination using the installation set Supra Standard 2 (separate installation instructions for the electrician).

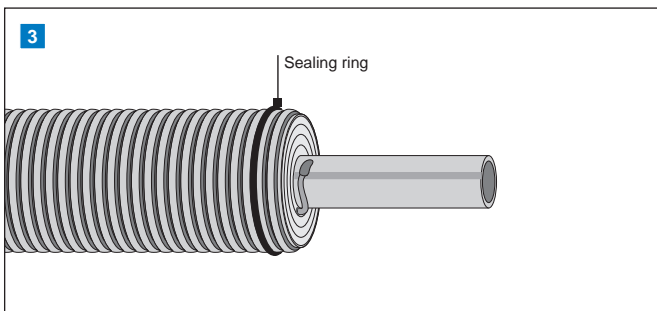

Place the seal in its place in the 2nd or 3rd groove. Cut the output for the service pipe of the end cap at the correct dimension.

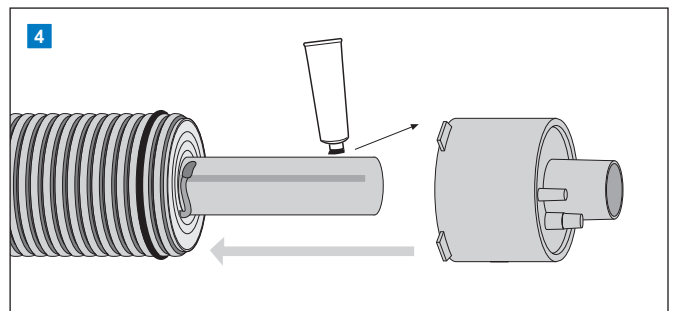

Pull the end cap on top of the pipe element using lubricant.

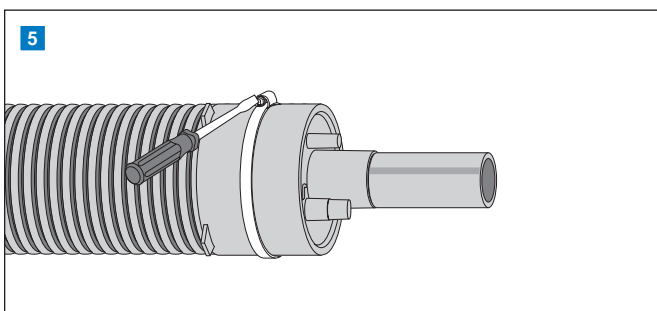

Place the clamping ring above the seal on the end cap and tighten.

## Uponor Ecoflex jacket joint set plus Supra Standard cable set S3



### Conducting the extension

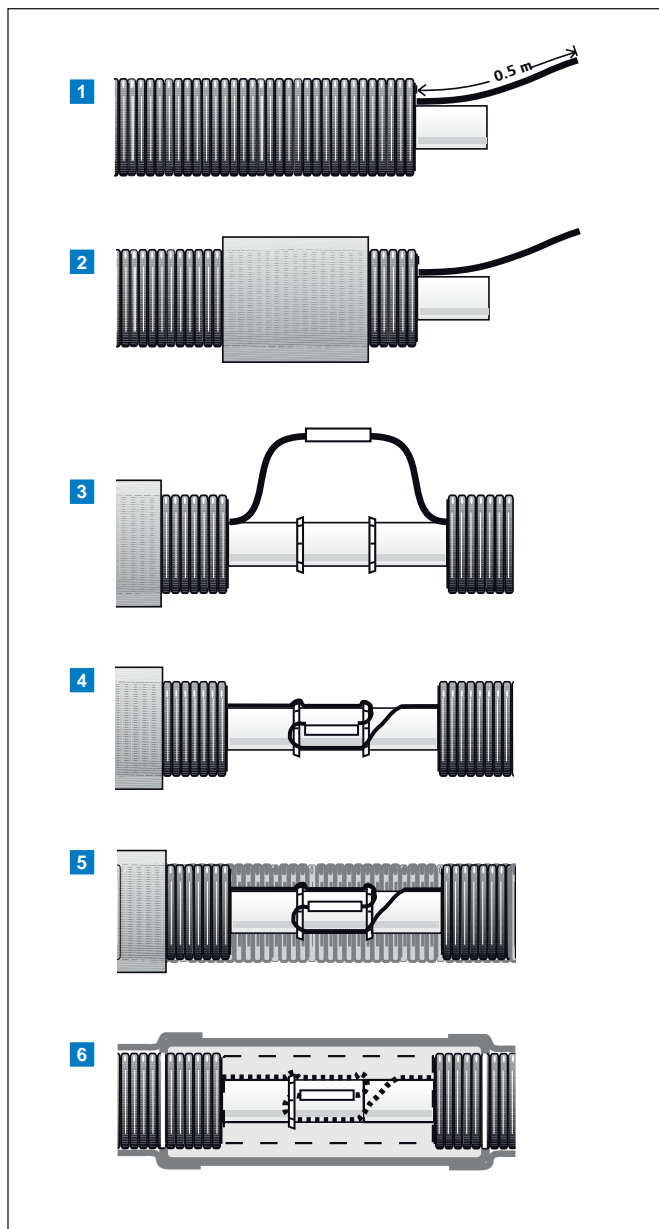

#### Note!

Remove the insulation in a way that allows to use it later to insulate the connector. Cut the service pipe at the required length. Do not damage the cable or the service pipe. Cut the service pipe so that the total length of uninsulated pipe ends and couplers do not exceed the length of the PE sleeve (400 mm). Clean the end of the pipe thoroughly (including the casing pipe).

- 1 Peel off the casing pipe and remove the thermal insulation taking into account the length of the PE sleeve 400 mm. Reserve 0.5 m of cable for the electrician.
- 2 Install the PE sleeve, length 400 mm and shrink sleeves on one pipe before installing the fastener.
- 3 Join the service pipes with couplers (not included in the set). Be careful not to damage the heating cable.

Carry out the extension of the heating cable using the supplies in the Supra Standard 3 installation set (separate installation instructions for the electrician).

- 4 Fasten the heating cable on the pipe extension using heatproof tape as shown in the picture. There must be no mechanical strain on the heating cable extension.
- 5 Install the insulation that was peeled off carefully on the extension. Fasten using tape.
- 6 Place the PE sleeve on the extension in a central position. Ensure that there is enough shrink sleeve on both casing pipes. Remove any protective paper left inside the shrink sleeve. Shrink using a yellow flame. Start the shrinking from the middle and heat evenly and slowly on all sides. First proceed to one end and then to the other. Be careful not to burn the shrink sleeve or the casing. When the surface of the shrink sleeve is smooth and adhesive is extruding from the ends of the shrink sleeve, the shrink sleeve has received enough warmth. Installation is ready when the extension has cooled down to ambient temperature.

# Uponor Ecoflex Supra Mantle: an insulated jacket for water pipe inlet

Uponor Ecoflex Supra Mantle protects the parts of a water pipe most susceptible to freezing, generally near the building foundation or inside a ventilated floor system. The jacket can be used for new buildings and renovation.

Supra Mantle is an insulated jacket pipe equipped with a heating cable that prevents the water pipe from freezing. Supra Mantle is an easy and effective way to protect the water pipes around the building from damage caused by freezing and, at the same time, it functions as a jacket pipe for the water pipe, enabling the exchanging of the water pipe in case damage occurs. The heat cable brings the required heat into the jacket pipe and the insulation layer helps retain the heat in the jacket pipe. Water remains unfrozen even in extremely cold temperatures in all locations

susceptible to freezing. Passes under the foundations and ventilated floor systems are the most typical locations in which water pipes freeze.

The heating cable connections in the Supra Mantle jacket pipe are ready for use. Connection to the electrical network is with a plug and the power outlet used must be equipped with a fault current protection. In the connection end, there is approximately 1 m of extra heating cable, which can be used to protect the service pipe from freezing during winter construction. The plug is connected to the socket when there is a risk of water pipe freezing. The maximum capacity of the cable is 10 W/m, enough to retain a water pipe unfrozen in a temperature of -25 °C.

## Pipe design



### 1 HDPE jacket pipe

The HDPE jacket pipe are made of corrugated HD polyethylene. Corrugation makes the casing robust against heavy traffic load but keeps flexibility for the installation.

### 2 Insulation

The insulation is made of crosslinked polyethylene foam. The closed-cell structure of the insulation prevents water absorption and provides good insulation capacity. The foamed plastic density is 30 kg/m<sup>3</sup> and thermal conductivity 0.038 W/mK.

### 3 Heating cable

The self-regulating heating cable has a nominal output of 10 W/m and supply voltage of 230 V.

### 4 Aluminium foil

The heating cable is attached to the insulation layer with aluminium foil.

## Uponor Ecoflex Supra Mantle



25 – 40 mm

### Main application

- Freeze-protection

### Insulating material

- PE-X

### Material jacket pipe

- HDPE

### Cable

- Self-regulating with plug

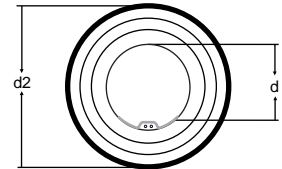

## Uponor Ecoflex Supra Mantle offering

Item no.	Jacket pipe d2 [mm]	d [mm]	Weight [kg/m]	Max. length on delivery [m]
1034177	90	25 – 40	5.4	5

# Uponor Ecoflex Mantle: self-regulating heating cable

The self-regulating cable has been designed particularly to prevent the pipes from freezing. This property combined with the insulation guarantees a dependable and safe solution. The heating part of the self-regulating heating cable is a conductive polymer extruded between two copper wires (phase and zero). In cold parts, a large current travels from one wire to another creating heat in the core material. In the warmer parts of the cable, the resistance of the material grows, the current slows down and the output is reduced. The heat production of the cable remains balanced and the heating capacity is regulated according to ambient conditions separately in each part of the pipe (see cross-section image). In low temperatures, the Supra Mantle provides adequate power to prevent freezing. As the temperature increases, the power is reduced. The self-regulating nature of the Supra PLUS means its use is safe.

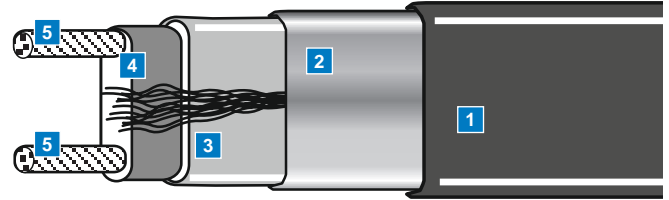

- 1** Outer jacket
- 2** Aluminum foil and drain wires
- 3** Electrical insulation
- 4** Core
- 5** Conductors

<b>External dimensions</b>	Width 12.5 mm, thickness 5.2 mm
<b>Smallest bending radius</b>	13 mm
<b>Supply voltage</b>	230 V
<b>The maximum permissible operating temperature</b>	Continuous 65 °C Momentary 85 °C
<b>Max. installation length</b>	100 m 10 A, 150 m 16 A
<b>Nominal output (on the surface of an insulated metal pipe +5 °C)</b>	10 W/m

## Self regulating cable 230 V 10 W/m

When the cable is cold, the resistor material contracts, opening several routes for power along the carbon crystals contained in the core material. The electrical current traveling through the core material creates the heat. In warm locations, the polymer in the resistor material expands and the number of routes for the electrical current is reduced.

This makes the resistance increase and the heat transfer capacity to decrease. In “hot” locations, the core material expands so that only a few routes are left for the power current in the core material. The result is a great resistance reducing the power transmission capacity further.

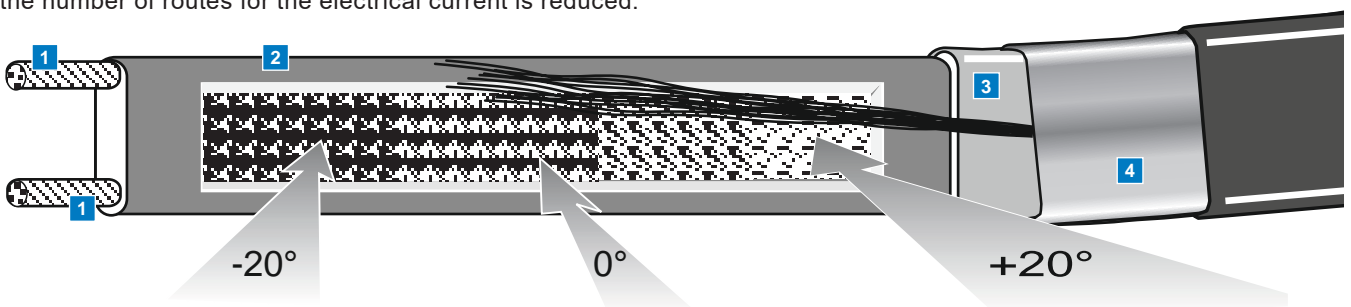

- 1** 1.2 mm<sup>2</sup> copper wires copper wires
- 2** Self-regulation resistor material
- 3** Polyolefin insulation
- 4** Aluminum foil and drain wires

## Installation

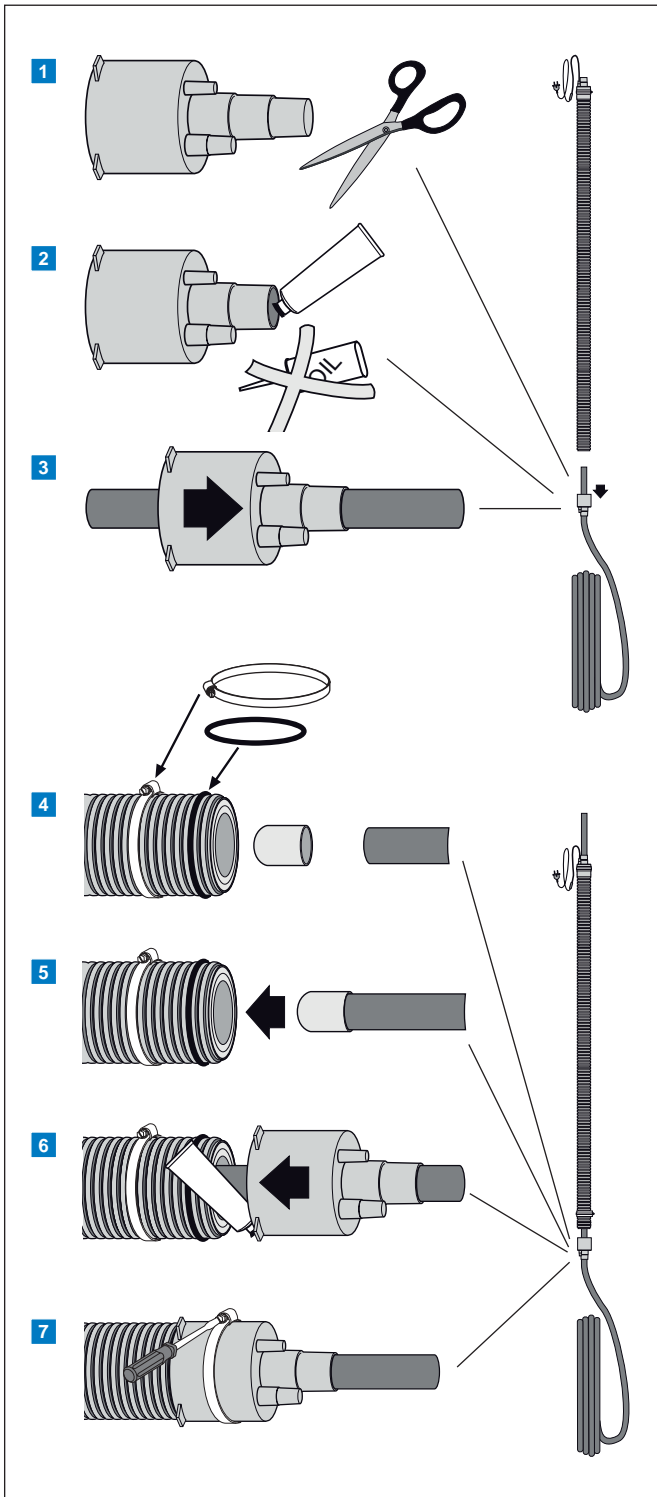

The installation of Supra Mantle is easiest when the water pipe is installed before any connectors are connected to the water pipe. The jacket is slid on the water pipe in the correct place and then the jacket containing the water pipe is installed in the correct location.

### Installation steps

- 1** Open the end cap output according to the water pipe diameter. Also open an output corresponding to the water pipe diameter on the end cap already in the connection end.
- 2** Lubricate the end cap with a suitable lubricant.
- 3** Fit the end cap on the water pipe taking the length of the jacket (5 or 10 m) into account. The end cap is used to seal the end of the jacket left in the ground.
- 4** Place the clamping ring on the jacket and install the sealing ring in the third groove on the jacket.
- 5** Fit a push plug at the end of the water pipe and push the water pipe through the jacket. Ensure that there is enough water pipe to make the connections.
- 6** Lubricate the end cap on the water pipe and fit it over the jacket.
- 7** Tighten the clamping ring on the end cap above the sealing ring.



# Technical specifications

## Properties of the Uponor PE-Xa pipes

### Heating pipe (Thermo)

Uponor heating pipes of PE-Xa are coated with an EVOH layer in accordance with DIN 4726 to prevent oxygen diffusion. They are therefore particularly suitable for carrying hot water at up to 95 °C and at a maximum pressure of 6 bar. The diameter/wall thickness ratio is in accordance with SDR 11 and SDR 7.4.

### Tap water pipe (Aqua)

The approved PEX pipes are suitable for carrying hot water services up to 95 °C, and at a maximum pressure of 10 bar. The Uponor PE-Xa pipe is manufactured, in accordance with DIN EN 15875-2, with a diameter/wall thickness ratio SDR of 7.4.



Mechanical properties		Value	Unit	Method
Density		0.938	g/cm <sup>3</sup>	
Tensile strength	(20 °C)	19-26	N/mm <sup>2</sup>	DIN 53455
	(100 °C)	9-13	N/mm <sup>2</sup>	
e-module	(20 °C)	800-900	N/mm <sup>2</sup>	DIN 53457
	(80 °C)	300-350	N/mm <sup>2</sup>	
Ultimate elongation	(20 °C)	350-550	%	DIN 53455
	(100 °C)	500-700	%	
Impact strength	(20 °C)	No rupture	kJ/mm <sup>2</sup>	DIN 53453
	(-140 °C)	No rupture	kJ/mm <sup>2</sup>	
Moisture absorption	(22 °C)	0.01	mg/4d	DIN 53472
Friction coefficient against steel		0.08-0.1	-	
Surface energy		34 x 10 <sup>-3</sup>	N/mm <sup>2</sup>	
Oxygen permeability	(20 °C)	0.8 x 10 <sup>-9</sup>	g m/m <sup>2</sup> s bar	
	(55 °C)	3.0 x 10 <sup>-9</sup>	g m/m <sup>2</sup> s bar	
Oxygen permeability Uponor – evalPEX	(80 °C)	3,6	mg/m <sup>2</sup> d	ISO 17455

Electrical properties		Value	Unit	Method
Specific internal resistance	(20 °C)	10 <sup>15</sup>	W/m	
Dielectric constant	(20 °C) 2.3	-		DIN 53483
Dielectric loss factor	(20 °C/50 Hz)	1 x 10 <sup>-3</sup>	-	DIN 53483
Disruptive voltage	(20 °C)	100	kV/mm	DIN 53481
(0.5 mm foil)				VDE 0303

Thermal properties		Value	Unit	Method
Temperature range		-100...+100	°C	
Linear expansion coefficient	(20 °C)	1.4 x 10 <sup>-4</sup>	m/m °C	DIN 53752
	(100 °C)	2.05 x 10 <sup>-4</sup>	m/m °C	
Softening temperature		+133	°C	DIN 53460
Specific heat		2.3	kJ/kg °C	
Coefficient thermal conductivity		0.35	W/m °C	DIN 4725

Long-term hydrostatic pressure resistance of pipes made from PE-X according DIN 16892

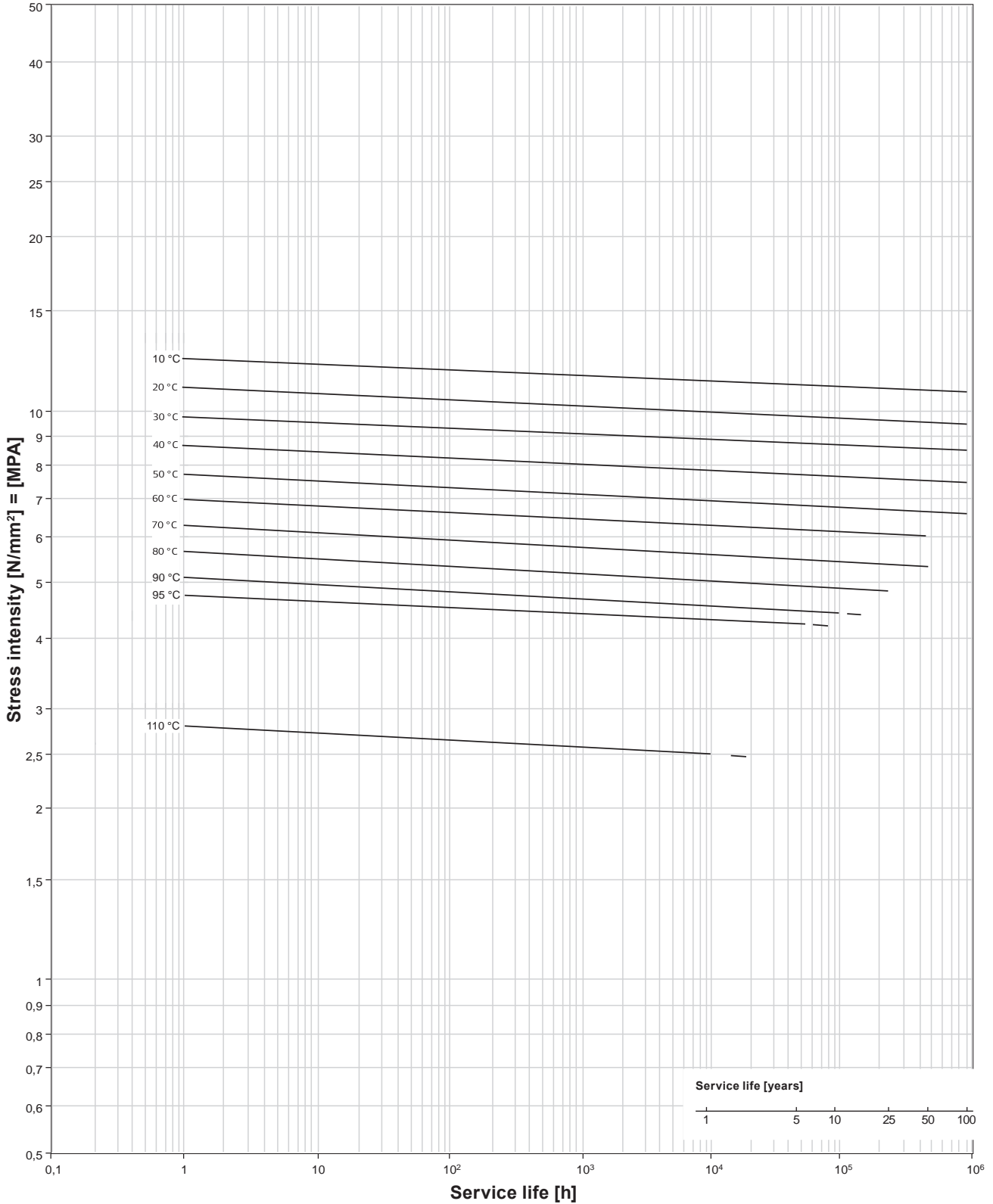

## PE service pipe (applications up to 20 °C) (Uponor Ecoflex Supra)

### Uponor Ecoflex Supra

The service pipe in our Uponor Ecoflex Supra pipes is produced either in HDPE (PE 100) or MDPE (PE 80) material. The pipes are designed especially for transporting cold potable water and/or for use in cooling water networks. The

HDPE service pipe used in Supra and Supra Plus 16 bar is DVGW-approved for transporting potable water. The black service pipes used in Supra Plus and Supra Standard have an Insta-CERT certification for water supply.

Property	Standard	PE 100	PE 80	Unit
Density at 23 °C	DIN 53479 ISO 1183 ISO/R 1183	0.96	0.95	kg/m <sup>3</sup>
Strength at break	ISO 572-2	38		N/mm <sup>2</sup>
Elongation at break	ISO 572-2	> 600	> 800	%
Tensile stress at yield	ISO 572-2	25	19	N/mm <sup>2</sup>
E-Modul (Zugversuch)	ISO 572-2	1100 – 1200	800	N/mm <sup>2</sup>
Tensile modulus	ISO 572-2	46	46	N/mm <sup>2</sup>
Vicat-Erweichungstemperatur	VST-A/50	DIN/ISO 306	127	°C
	VST-B/50		77	°C
Thermal conductivity at 20 °C	DIN 52612	0,38	0,38	W/(m*K)
Oxidation induction time (200 °C)	EN 728	> 20	> 20	min
Operation temperature	–	- 10...+ 20 (16 bar)		°C
Thermal linear expansion coefficient	DIN 53752	1,8 x 10 <sup>-4</sup>	1,8 x 10 <sup>-4</sup>	1/ °C
Fire class	DIN 4102 part 2	B2	B2	
	EN 13501 part 1	E	E	

### Service life: HDPE medium pipe

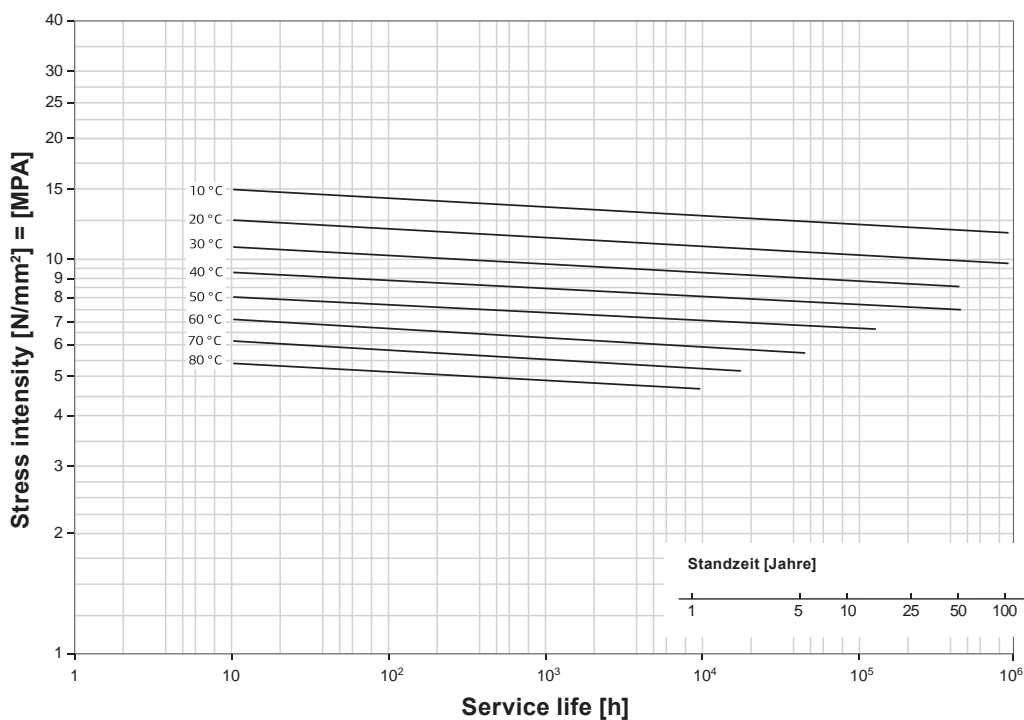

## Long-term properties

Uponor PE-Xa pipes have been type approved by DVGW since 1977.

The approval is based on testing by international testing institutes. Stress tests show that at a temperature of 70 °C and a

pressure level of 10 bar in continuous operation the pipe has an estimated service life of more than 50 years.

## Classification of service conditions according to EN ISO 15875 of PE-Xa pipes for pre-insulated pipes

Uponor PE-Xa pipe systems are designed according to EN ISO 15875 (Plastics piping systems for hot and cold water installations - crosslinked polyethylene (PE-X)).

Application class	Operating temperature $\theta_D$ [°C]	Time at $T_D$ [years]	$T_{max}$ [°C]	Time at $T_{max}$ [years]	$T_{mal}$ [°C]	Time at $T_{mal}$ [h]	Typical application
1 <sup>a</sup>	60	49	80	1	95	100	Hot water distribution (60 °C)
2 <sup>a</sup>	70	49	80	1	95	100	Hot water distribution (70 °C)
4 <sup>b</sup>	20	2.5	70	2.5	100	100	Underfloor heating and low-temperature radiators
	Followed by						
	40	20					
	Followed by						
60		25					
Followed by (see next column)		Followed by (see next column)					
5 <sup>b</sup>	20	14	90	1	100	100	High-temperature radiators
	Followed by						
	60	25					
	Followed by						
80		10	Followed by (see next column)				

<sup>a</sup> In order to comply with national regulations, a country may apply either class 1 or 2.

<sup>b</sup> Where more than one operating temperature is shown for any class, the times must be added up, e.g. the operating temperature profile for 50 years for class 5 is: 20 °C for 14 years followed by 60 °C for 25 years, 80 °C for 10 years, 90 °C for one year and 100 °C for 100 h.

NB! For values exceeding those in the table for  $T_D$ ,  $T_{max}$  and  $T_{mal}$  this standard is not applicable.

## Classification of service conditions according to EN 15632-2 and 3 of pre-insulated PE-Xa pipes

The pre-insulated PE-Xa heating pipes and related system components from Uponor are designed according to EN 15632 District heating pipes – Pre-insulated flexible pipe systems – Part 2: Bonded system with plastic service pipes - Requirements and test methods (Ecoflex Thermo PRO) and Part 3: Non bonded system with plastic service pipes (Ecoflex Thermo and Ecoflex Varia).

### Operating temperatures and service life

The Uponor pre-insulated PE-Xa pipe systems according to EN 15632 are designed for a service life time of at least 30 years when operated at the following temperature profile: 29 years at 80 °C + 1 year at 90 °C + 100 h at 95 °C.

Other temperature/time profiles can be applied in accordance

with EN ISO 13760 (Miner's Rule). Further information is given in EN 15632 Part 2 and 3, Annex A. The maximum operating temperature shall not exceed 95 °C.

### Operating pressure

Uponor pre-insulated PE-Xa pipe systems are, in accordance with EN 15632-2 and 3, designed for continuous operating pressures of 6 bar (SDR 11) and 10 bar (SDR 7,4).

## Material properties of the jacket pipe

The stable, impact-resistant PE-HD jacket pipe protects the insulation and medium pipes from external loads. The special design of the pipe configuration ensures a high flexibility and high static load capacity.

Property	Value	Unit	Method
Material	PE-HD (PE 80)	-	-
UV-stabilised	yes	-	-
Fire behaviour	B2	-	DIN 4102
Density	957 – 959	kg/m <sup>3</sup>	ISO 1183
Modulus of elasticity	~ 1000	MPa	ISO 527-2

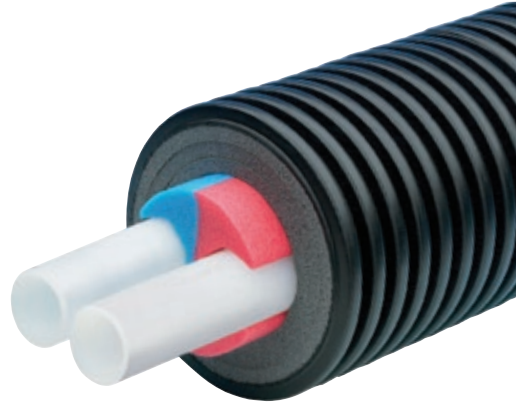

## Material properties of the insulation

The age-resistant cross linked PE-foam insulation consists of crosslinked polyethylen and has, due to its closed cell structure, only minimal water absorption. The multi-layer design combines maximum flexibility and optimum heat insulation.

Property	Value	Unit	Method
Density	approx. 28	kg/m <sup>3</sup>	DIN 53420
Tensile strength	28	N/cm <sup>2</sup>	DIN 53571
Operating temperature limits-			
- Minimum	-40	°C	
- Maximum	+95	°C	
Water absorption	< 1,0	volume-%	EN 489
Fire behaviour	B2	-	DIN 4102
Compressive strenght 50 % deformation	73	kPa	DIN 53577
Water vapour transmission/ 10 mm thickness	1,55	g/m <sup>2</sup> d	DIN 53429
Thermal conductivity	40 °C : 0,040 W/m K		DIN 52612

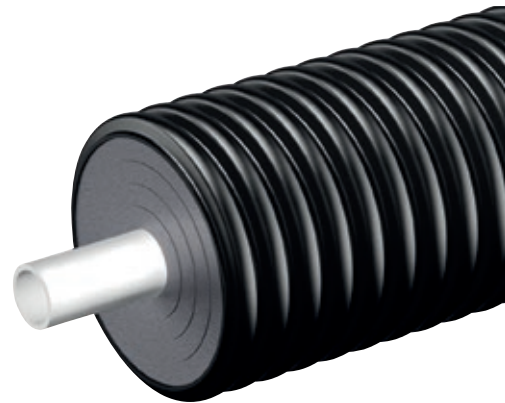

The used PUR insulation material is made of a halogen-free polyurethane foam core and an additional insulation layer made of closed cross linked PE-foam. In combination with the corrugated outer casing this ensure maximum flexibility. In addition to the excellent insulating properties the closed cell structure of the material guarantes a minimal water absorption. Thre material is free of CFC / HCFC and HFC.

Property	Value	Unit	Method
Density	60	kg/m <sup>3</sup>	ISO
Tensile strength	-	kPa	ISO 1926
Operating temperature limits-			
- Minimum	-80	°C	
- Maximum	+110	°C	
Water absorption	3-4	volume-%	EN 489
Thermal conductivity	Thermo PRO 50 °C: 0,0219 W/m K		DIN 52612



# Appendix

## Uponor PE-Xa pipes - weight and volume

### EVAL PEX pipes PN 6

Pipe dim OD x s [mm]	ID [mm]	Weight [kg/m]	Volume [l/m]
25 x 2.3	20.4	0.183	0.31
32 x 2.9	26.2	0.268	0.50
40 x 3.7	32.6	0.430	0.85
50 x 4.6	40.8	0.665	1.32
63 x 5.8	51.4	1.048	2.08
75 x 6.8	61.2	1.461	2.96
90 x 8.2	73.6	2.113	4.25
110 x 10	90.0	3.141	6.29
125 x 11.4	102.2	4.050	8.20

### EVAL PEX pipes PN 10

Pipe dim OD x s [mm]	ID [mm]	Weight [kg/m]	Volume [l/m]
18 x 2.5	13.0	0.116	0.13
25 x 3.5	18.0	0.236	0.245
32 x 4.4	23.3	0.380	0.42
40 x 5.5	29.0	0.592	0.66
50 x 6.9	36.2	0.923	1.03
63 x 8.6	45.8	1.459	1.65
75 x 10.3	54.4	2.077	2.31
90 x 12.3	65.2	2.965	3.26
110 x 15.1	79.8	4.442	4.85

### Comparative table of PN 6 / SDR 11 pipes

The table shows the corresponding dimensions of PEX and steel pipes.

PEX OD	OD/ID	Steel pipes DN	OD/ID
25	25/20.4	20	26.9/22.9
32	32/26.2	25	33.7/28.1
40	40/32.6	32	42.4/37.2
50	50/40.8	40	48.3/43.1
63	63/51.4	50	60.3/54.5
75	75/61.2	65	76.1/70.3
90	90/73.6	80	88.9/82.5
110	110/90.0	100	114.3/107.1
125	125/102.2	125	139.7/132.5

### Comparative table of PN 10 / SDR 7.4 pipes

The table shows the corresponding dimensions of PEX and copper pipes.

PEX OD	OD/ID	Copper pipes DN	OD/ID
25	25/18	22	22/20
32	32/23.2	28	28/25.6
40	40/28.6	35	35/32.0
50	50/36.2	42	42/39.0
63	63/45.7	54	54/51.0
75	75/54.4	63	63/59.0
90	90/65.2	76,1	76.1/72.1
110	110/79.8	88,9	88.9/84.9





# Uponor

**Uponor Corporation**

Äyritie 20  
01510 Vantaa  
Finland

**T** +358 (0)20 129 211  
**F** +358 (0)20 129 2841



[www.uponor.com](http://www.uponor.com)